

SANITIZER SNT-03



ENGLISH.....5

SUMMARY

Revision of the Manual.....	5
INTRODUCTION.....	6
1 LEGEND OF THE SYMBOLS USED.....	7
2 GENERAL SAFETY RULES FOR AUTOMOTIVE ENVIRONMENTS.....	9
2.1 Glossary.....	9
2.2 Operator Safety Regulations.....	9
2.2.1 General Safety Regulations.....	9
2.2.2 Risk of Asphyxiation.....	9
2.2.3 Risk of Impact and Crushing.....	10
2.2.4 Hazards Caused by Moving Parts.....	10
2.2.5 Risk of Burning or Scalding.....	10
2.2.6 Fire and Explosion Hazard.....	11
2.2.7 Noise Hazard.....	11
2.2.8 High Voltage Hazard.....	11
2.2.9 Poisoning Hazard.....	12
2.3 General User and Maintenance Warnings.....	12
3 GENERAL SAFETY RULES FOR FOOD AND DOMESTIC ENVIRONMENTS.....	13
3.1 Glossary.....	13
3.2 Operator Safety Regulations.....	13
3.2.1 General Safety Regulations.....	13
3.2.2 Risk of Asphyxiation.....	13
3.2.3 Poisoning Hazard.....	14
3.2.4 High Voltage Hazard.....	14
3.3 General User and Maintenance Warnings.....	14
4 SPECIFIC SAFETY RULES FOR USING SANITIZER SNT-O3.....	15
4.1 Glossary.....	15
4.2 General Rules.....	15
4.3 Operator Safety.....	16
4.4 Device Safety.....	18
5 OZONE (O3) SAFETY SHEET.....	20
6 FUNCTIONING OF THE RADIO DEVICES.....	22
7 ENVIRONMENTAL INFORMATION.....	23

8	NORMATIVE INFORMATION	24
9	SANITIZER SNT-O3	25
10	OPERATION	26
11	DESCRIPTION	30
12	TECHNICAL FEATURES	31
12.1	Sanitiser	31
12.2	Remote control	33
13	POWER SUPPLY	34
13.1	Cigar lighter cable	34
13.2	Power Supply from the Mains	35
14	POWER ON/OFF	36
15	COMMUNICATION	37
15.1	Radio control	38
15.2	Display Unit	39
16	RADIO CONTROL: COMMANDS AND NOTIFICATIONS	40
16.1	Volume Selection	41
16.2	Programmed Maintenance Warning	43
17	NOTIFICATIONS VIA LED	44
18	USE	45
18.1	Preliminary Checks Before the Sanitation	46
18.2	Sanitation	46
18.3	Post-Sanitation Checks	48
19	EMERGENCY SHUTOFF	49
20	APP AND SOFTWARE	50
20.1	Firmware Update	51
21	MAINTENANCE	52
21.1	Filter Replacement	53
21.2	Ozone Sensor Replacement	61
21.3	Ozone Generator Replacement	61
21.4	Radio Control Battery Replacement	62
21.5	Cigar Lighter Cable Fuse Replacement	63
22	TROUBLESHOOTING	64
23	LEGAL NOTICES	66

Revision of the Manual

This document is **revision 02** of the **SANITIZER SNT-O3** technical manual.

Issue Date: 23/06/2020

INTRODUCTION

Dear Customer,

Thank you for choosing our product.

We are certain that you will get the greatest satisfaction from it and receive a great deal of help in your work.

Please read through the instructions in this manual carefully and keep it for future reference.

Reading and understanding the following manual will help you to avoid damage or personal injury caused by improper use of the product to which it refers.

The manufacturer reserves the right to make any changes deemed necessary to improve the manual for any technical or marketing requirement; the company may do so at any time without prior notice.

This product is intended to be used only by technicians specialised in the automotive field and, in general, by personnel properly trained in environment sanitation operations with ozone. For this reason the information, reading and understanding this manual cannot substitute an adequate knowledge that who uses the product must have already acquired.

The sole purpose of the manual is to illustrate the functioning of the product sold. It is not intended to offer technical training of any kind and users will therefore carry out any interventions under their own responsibility and will be accountable for any damage or personal injury caused by negligence, carelessness or inexperience, regardless of the fact that this product has been used following the information contained in this manual.

Any additions to this manual, useful in describing the new versions of the program and the new functions associated to it, may be sent to you through the technical bulletin service.

This manual is to be considered an essential part of the product it refers to. If it is resold, the original buyer is therefore required to forward the manual to the new owner.











Reproduction, whole or in part, of this manual in any form without written authorisation by the manufacturer is strictly forbidden.

The original manual was written in Italian, every other language is a translation of the original manual.

© **copyright and database rights 2020.** The material contained in this publication is protected by copyright and database rights. All rights are reserved by law and under international conventions.

1 LEGEND OF THE SYMBOLS USED

The symbols used in the manual are described in this chapter.

	Asphyxiation Risk
	Explosion Risk
	High Voltage Hazard
	Fire / Burn risk
	Poisoning Hazard
	Corrosive Substances Risk
	Noise Hazard
	Moving Parts Risk
	Crushing Risk
	Risk of Stumbling
	Laser Radiation Hazard
	General Risk
	Mandatory reading
	It indicates a hazardous situation which, if not avoided, will result in serious permanent injury or death.
	It indicates a hazardous situation which, if not avoided, may result in serious permanent injury or death.

 CAUTION	It indicates a hazardous situation which, if not avoided, may result in minor injury.
NOTICE	This is not a safety symbol. It indicates a hazardous situation which, if not avoided, may result in material damage.
INFORMATION	This is not a safety symbol, but indicates important information.

2 GENERAL SAFETY RULES FOR AUTOMOTIVE ENVIRONMENTS

The safety rules indicated below refer to the behaviours to adopt when operating in automotive environments (e.g. inside a workshop).

2.1 Glossary

- **Equipment:** *the totality of the tools and devices used to carry out the assigned tasks.*
- **Operator:** *qualified person, adequately trained to carry out the tasks assigned using the equipment.*
- **Workplace:** *the place where the operator must carry out her/his work.*

2.2 Operator Safety Regulations

2.2.1 General Safety Regulations

- *The operator must be completely clear-headed and sober and not take drugs nor drink alcohol before or when performing the tasks.*
- *The operator must not smoke during device operation.*
- *The operator must carefully read and understand all the information and instructions in the technical documents provided with the tools and devices used to perform the tasks.*
- *The operator must follow all the instructions provided in the technical documents.*
- *The operator must always watch over the tools and devices during the various operating phases.*
- *The operator must make sure she/he is working in an environment which is suitable for the operations that must be carried out.*
- *The operator must report any faults or potentially hazardous situation in connection with the workplace or the tools and devices used to perform the tasks.*
- *The operator must carefully follow the safety regulations required for the workplace in which she/he is working and required by the operations she/he has been asked to carry out.*

2.2.2 Risk of Asphyxiation



Exhaust gases from internal combustion engines, whether petrol or diesel, are hazardous to your health and can cause serious harm to your body.

Safety Precautions:

- *The workplace must be equipped with an appropriate ventilation and air extraction system and must be in compliance with standards according to current national laws.*
- *Always activate the air extraction system when working in closed environments.*

2.2.3 Risk of Impact and Crushing

WARNING



The vehicles which are undergoing A/C system recharging operations and the equipment must be properly blocked using specific mechanical blocks while being serviced.

Safety Precautions:

- *Always make sure that the vehicle is in neutral gear (or that it is set in parking position in case of a vehicle equipped with automatic transmission).*
- *Always activate the hand brake or parking brake on the vehicle.*
- *Always block the wheels on the vehicle with the specific mechanical blocks.*
- *Make sure the device is stable, on a flat surface and that the wheels are locked with the specific mechanical blocks.*

2.2.4 Hazards Caused by Moving Parts

WARNING



Vehicle engines include parts that move, both while running and not running (e.g.: the cooling fan is controlled by a thermal switch in connection with the coolant temperature and can activate even when the vehicle is off), that can injure the operator.

Safety Precautions:

- *Keep hands away from moving parts.*
- *Disconnect the engine cooling fan each time the engine you are working on is still hot. This will avoid the fan from becoming activated unexpectedly even when the engine is off.*
- *Do not wear ties, loose clothes, wrist jewellery or watches when working on a vehicle.*
- *Keep connection cables, probes and similar devices away from the moving parts of the engine.*

2.2.5 Risk of Burning or Scalding

WARNING



The parts that are exposed to high temperatures in engines that are moving or have just stopped can burn the operator.

Remember that catalytic mufflers reach very high temperatures, able to cause serious burns or even start fires.

Acid in the vehicle batteries is another potential hazard.

Safety Precautions:

- *Protect your face, hands, and feet by using suitable protection.*
- *Avoid contact with hot surfaces, such as spark plugs, exhaust pipes, radiators and connections within the cooling system.*

- *Make sure there are no oil stains, rags, paper or other inflammable material near the muffler.*
- *Avoid splashing electrolyte onto your skin, eyes and clothes, as it is a corrosive and highly toxic compound.*

2.2.6 Fire and Explosion Hazard



The following are potential fires and / or explosion hazards:

- **The fuels used by the vehicle and the vapours released by these fuels.**
- **The refrigerants used by the A/C system.**
- **The acid in the vehicle batteries.**

Safety Precautions:

- *Let the engine cool down.*
- *Do NOT smoke near the vehicle.*
- *Do NOT expose the vehicle to open flames.*
- *Make sure that the electrical connections are all well insulated.*
- *Collect any fuel that might have spilled.*
- *Collect any refrigerant that might have spilled.*
- *Make sure you are always working in an environment equipped with a good ventilation and air extraction system.*
- *Always activate the air extraction system when working in closed environments.*
- *Cover the openings of the batteries with a wet cloth in order to stifle the explosive gases before proceeding in testing or recharging.*
- *Avoid causing sparks when connecting cables to the battery.*

2.2.7 Noise Hazard



Loud noises that may occur within the workplace, especially during service operations, may damage the operator's hearing.

Safety Precautions:

- *Protect your ears with suitable protective ear wear.*

2.2.8 High Voltage Hazard



The mains voltage that powers the equipment in the workplace and the voltage within the vehicle's ignition system are a potential shock hazard to the operator.

Safety Precautions:

- *Make sure the electrical system in the workplace is compliant to current national standards.*
- *Make sure the device being used is connected to ground.*
- *Cut off the power supply voltage before connecting or disconnecting cables.*
- *Do NOT touch the high voltage cables when the engine is on.*
- *Operate in conditions of insulation from ground.*
- *Work with dry hands only.*
- *Keep conductive liquids away from the engine while working.*
- *Never leave tools on the battery in order to avoid accidental contacts.*

2.2.9 Poisoning Hazard



The hoses used to extract the gases can release toxic gases, dangerous to the operator if exposed to temperatures higher than 250 °C or in case of a fire.

Safety Precautions:

- *Should you inhale these gases, seek medical advice immediately.*
- *Use neoprene or PVC gloves when eliminating combustion deposits.*

2.3 General User and Maintenance Warnings

When using the equipment or carrying out ordinary maintenance (e.g. fuse replacement), carefully follow the information provided below:

- *Do not remove or damage the labels/tags and the warnings on the equipment; do NOT in any case make them illegible.*
- *Do not remove, or block, any safety devices the equipment is provided with.*
- *Only use original spare parts or spare parts approved by the manufacturer.*
- *Contact your retailer for any extraordinary maintenance.*
- *Periodically check the electrical connections of the tools and devices making sure they are in good condition and immediately replacing any damaged cables.*
- *Periodically check parts that are subject to wear and replace them if necessary.*
- *Do not open nor disassemble the equipment for operations other than the ones indicated in the MAINTENANCE chapter.*

3 GENERAL SAFETY RULES FOR FOOD AND DOMESTIC ENVIRONMENTS

The safety rules indicate below refer to the behaviours to adopt when operating in domestic (e.g. inside an accommodation facility) and food environments.

3.1 Glossary

- **Equipment:** *the totality of the tools and devices used to carry out the assigned tasks.*
- **Operator:** *qualified person, adequately trained to carry out the tasks assigned using the equipment.*
- **Workplace:** *the place where the operator must carry out her/his work.*

3.2 Operator Safety Regulations

3.2.1 General Safety Regulations

- *The operator must be completely clear-headed and sober and not take drugs nor drink alcohol before or when performing the tasks.*
- *The operator must not smoke during device operation.*
- *The operator must carefully read and understand all the information and instructions in the technical documents provided with the equipment.*
- *The operator must follow all the instructions provided in the technical documents.*
- *The operator must always watch over the equipment during the various operating phases.*
- *The operator must make sure she/he is working in an environment which is suitable for the operations that must be carried out.*
- *The operator must report any faults or potentially hazardous situation in connection with the workplace or the equipment.*
- *The operator must carefully follow the safety regulations required for the workplace in which she/he is working and required by the operations she/he has been asked to carry out.*

(*) *The monitoring must be done outside the environments being sanitised.*

3.2.2 Risk of Asphyxiation



Certain products and solvents may release fumes that are harmful and can cause severe injuries.

Safety Precautions:

- *The workplace must be equipped with an appropriate ventilation and be in compliance with standards according to current national laws.*
- *Always refer to the safety sheets of the products used.*
- *Always use appropriate Personal Protection Equipment (PPE) when carrying out the tasks.*
- *Should you inhale these gases, seek medical advice immediately.*

3.2.3 Poisoning Hazard



The accidental ingestion of some products can be harmful and cause severe injuries.



Safety Precautions:

- *Always refer to the safety sheets of the products used.*
- *In case of ingestion, seek medical advice immediately.*

3.2.4 High Voltage Hazard



The voltage in the mains that powers the equipment in the workplace is a potential shock hazard for the operator.



Safety Precautions:

- *Make sure the electrical system in the workplace is compliant to current national standards.*
- *Make sure the device being used is connected to ground.*
- *Cut off the power supply voltage before connecting or disconnecting cables.*
- *Operate in conditions of insulation from ground.*
- *Work with dry hands only.*
- *Keep conductive liquids away from the equipment.*

3.3 General User and Maintenance Warnings

When using the equipment or carrying out ordinary maintenance (e.g. fuse replacement), carefully follow the information provided below:

- *Do not remove or damage the labels/tags and the warnings on the equipment; do NOT in any case make them illegible.*
- *Do not remove, or block, any safety devices the equipment is provided with.*
- *Only use original spare parts or spare parts approved by the manufacturer.*
- *Contact your retailer for any extraordinary maintenance.*
- *Periodically check the electrical connections of the tools and devices making sure they are in good condition and immediately replacing any damaged cables.*
- *Periodically check parts that are subject to wear and replace them if necessary.*
- *Do not open nor disassemble the equipment for operations other than the ones indicated in the MAINTENANCE chapter.*

4 SPECIFIC SAFETY RULES FOR USING SANITIZER SNT-O3

The technology used for the design and production testing of **SANITIZER SNT-O3** makes it a reliable, simple and safe device to use.

Personnel in charge of using **SANITIZER SNT-O3** is required to follow the general safety rules, use **SANITIZER SNT-O3** for its intended use only and carry out the maintenance properly as described in this manual.

All the requirements based on the following must be assessed and applied:

- *Labour inspectorate.*
- *Trade associations.*
- *Vehicles manufacturers.*
- *Anti-pollution regulations.*
- *Environment sanitation.*

WARNING



This device was not designed per sanitising and sterilising medical environments.

For this reason it must not be used for the sanitation of environments such as:

- **operating rooms**
- **dental studios**
- **clinic**
- **ambulances**

and in general any environment in which medical services take place or for which there are specific ministerial regulations in terms of sterilisation and sanitation.

4.1 Glossary

- **Device:** *SANITIZER SNT-O3.*
- **Operator:** *person who uses the device.*
- **Environment:** *any compartment in a vehicle (e.g. passenger compartment, boot, etc.), dedicated to the transportation of people, animals, plants or goods, including containers of a maximum size of 120 m³; any closed space, dedicated to the use by people (e.g. hotel room) or to the storage of goods (e.g. warehouse) of a maximum size of 120 m³.*

INFORMATION

The definition of "operator" cannot be applied to minors or to people with reduced physical, sensory or mental capabilities or without any experience or knowledge required.

4.2 General Rules

- *The operator must carefully read all the information and instructions in the technical documents provided with the device.*
- *If the operator is not able to read this manual, the operating instructions and the safety indications, they must be read and discussed in the operator's native language.*

- The operator that works on vehicles must have basic knowledge of mechanics, automotive engineering, car repair and of the potential dangers that may arise during self-diagnosis operations.
- The operator that works in different closed environments other than the ones connected with the automotive environment must have appropriate knowledge regarding the sanitation of environments.

4.3 Operator Safety



The ozone is toxic and irritating mainly for the respiratory tracts (concentration > di 0.3 ppm), slightly for eyes and rarely for the skin.

Extended exposure can cause severe injuries.

Safety Measures:

- Do not access an environment being treated before the sanitation procedure is completed.
- Keep a distance of at least one metre from the environment being treated and from any of its openings (e.g. door, window, liftgate, etc.).
- In case of use in a vehicle: make sure there is a good ventilation in the workshop (at least 4 complete air changes every hour) or, alternatively, carry out the sanitation operations outdoors.
- If you need to access an environment before the sanitation procedure completes properly, wear protective glasses and a breathing mask that guarantees protection against high concentrations of ozone (> 3.3 ppm).
- In case of emergency and if you do not have a protective mask, breathe slowly and for a short period of time through a wet cloth.
- In case of illness, refer to the indications in the chart below:

Symptoms	Inhalation	Behaviour to adopt:
Irritation in nose, throat, eyes	light	Go outdoors until the symptoms go away.
Cough, headache, nausea	average	Breathe medical oxygen until the symptoms go away. This operation must be carried out under the supervision of personnel adequately trained in first aid operations.
Chest pain, breath shortness	severe	Call for help. Contact the emergency room immediately.

! WARNING

The ozone itself is not flammable, but it is highly instable and reactive and can start or accelerate combustion or cause explosions when in contact with other elements among which:

- alkanes - $C_nH_{(2n+2)}$, e.g. methane CH_4
- ethylene - C_2H_4
- benzene - C_6H_6
- diethyl ether - $(C_2H_5)_2O$
- nitrogen tetroxide - N_2O_4
- bromine - Br^-
- hydrogen bromide/bromhidric acid - HBr
- nitro-glycerine - $C_3H_5(ONO_2)_3$

These reactions can cause severe damages and injuries.

Safety Measures:

- *Do not use the device in environments in which there are, even in a minimum amount, the elements listed above.*
- *Make sure inside and around the environment that must be sanitised there are not any trigger sources such as: peeled cables that may produce sparks, free flames, high temperature surfaces (e.g. electronic lighters with filament), etc.*
- *Do not smoke inside or around the environment being sanitised during the treatment and for at least 1 hour after the end of the sanitation.*
- *Use any extinguishing agent to put out the fire.*

! WARNING

The ozone easily connects with NO_x type gases and can generate potentially toxic compounds such as nitric acid (HNO_3).

Exposure to these compounds can cause severe injuries.

Safety Measures:

- *Always keep the device clean.*
- *At the slightest hint of malfunction, turn off the device and contact technical assistance.*
- *If need, follow the emergency shutoff and securing procedure of the device and environment.*
- *Thoroughly follow the replacement expiration dates of the consumable parts (e.g. filters).*
- *Wear protective gloves and glasses during all the sanitation phases that require an intervention by the operator and during all the maintenance operations.*

! WARNING

The device has a specific intended use and was designed and manufactured for a specific method of use.

Any other different use from the ones indicated in this manual expose to the risk of damages and injuries.

Safety Measures:

- *Use the device only in compliance with its intended use.*
- *Use the device only based on the mode described in this manual.*
- *Do not use hoses or any other type of duct to channel the air and gas flows coming into and exiting from the device.*

WARNING



High-voltage current runs inside the device.

Coming into contact with this voltage exposes to the risk of severe injuries.

Safety Measures:

- *Do not disassemble the device for any reason.*
- *Disconnect the device before any maintenance operation.*
- *Wear protective gloves that provide an adequate electrical insulation during all maintenance operations.*

WARNING



The airbags inflate with great force.

In case of explosion, a device located in the airbag's expansion area will be thrown with force causing severe damages.

Safety Measures:

- *Do not place the device in the airbag expansion areas.*

WARNING



The electromagnetic compatibility tests carried out on the device guarantee that it can be adapted to the technologies normally used on vehicles (e.g. engine control, ABS, airbag, etc.). Nevertheless, if malfunctions occur, contact the vehicle's dealer.

4.4 Device Safety

NOTICE



The device was designed to be used in specific environmental conditions.

Using the device in environments with temperatures and humidity that differ from those specified may impair its efficiency.

Safety measures:

- *Always place the device in a dry area.*
- *Do not expose or use the device close to heat sources.*
- *Position the device in order to guarantee its proper ventilation.*
- *Do not use corrosive chemicals, solvents or harsh detergents to clean the device.*
- *Do not use in dusty environments and/or near vaporised liquids.*

NOTICE

The device was designed to be mechanically tough and suitable for use in a workshop and in general in a closed environment.

Careless use and excessive mechanical strain may impair its efficiency.

Safety measures:

- *Do not drop, shake or knock the device.*
- *Do not place the device where it could fall into water. Avoid any contact with water.*
- *Do not place objects over the cables nor bend them.*
- *Do not carry out any type of intervention that may damage the device.*
- *Do not open or disassemble the device.*
- *When moving the device, use the handle or the trolley (optional) only.*

NOTICE

The device was manufactured to be electrically safe and to work with specific supply voltage levels; however it is not protected against polarity inversion.

Failure to comply with the specifications related to the power supply may impair the device's efficiency.

Safety measures:

- *Do not wet the device with water or other liquids.*
- *Use the device on vehicles with a 12 V DC power supply and chassis connected to the negative pole.*
- *The connection for the device's power supply must always be through the battery system of the vehicle being tested using the wiring indicated in this manual or a 220 V network with a specific charger (optional).*
- *Do not use external batteries to power the device.*
- *Pay the utmost attention to battery terminals and cables when setting up the connection to the vehicle. This will avoid false contacts and/or accidentally connecting the cables to metallic parts of the vehicle being tested.*

5 OZONE (O₃) SAFETY SHEET

Chemical name: ozone

Common names: triatomic ozone, active oxygen

Chemical formula: O₃

CAN number: 10028-15-6 - CE n° 233-069-2

PHYSICAL AND CHEMICAL PROPRIETIES:

State:	gaseous
Molecular mass:	48.0 u
Colour:	blue
Olfactory perception:	0,02÷0,05 ppm
Damage threshold:	> 0,3 ppm
Tolerability threshold:	0,1 ppm
Odour:	acid and pungent (typical)
Point of fusion:	-193°C (-315°F)
Boiling point:	-112°C (-169°F)
Vapour pressure:	>101325 pa (1 atm)
Vapour density:	1.6
Relative density:	2,144 g/l

USE OF THE PRODUCT

Ozone produced in a gaseous form, on site, by a corona discharge generator, for various application in the air or in liquids.

TOXICOLOGICAL INFORMATION

The ozone is toxic and irritating mainly for the respiratory tracts (concentration > 0.3 ppm), slightly for eyes and rarely for the skin.

RESPIRATORY PROTECTION

Always use an appropriate breathing mask to access area with a high concentration of ozone (> 0.3 ppm).

If you do not have a mask, breath slowly, for a short period of time,, through a wet cloth.

FIRST AID MEASURES:

The first symptoms of intoxication from ozone are burning in the nose, throat and eyes.

Symptoms	Inhalation	Behaviour to adopt
Irritation in nose, throat and eyes	light	go outdoors
Cough, headache, nausea	average	breath medical oxygen
Chest pain, breath shortness	severe	call first aid

FIREFIGHTING MEASURES

The ozone itself is not flammable, but it can start or accelerate combustion or cause explosions when in contact with other elements (see below).

Use an extinguishing agent to put out the fire.

STABILITY AND REACTIVITY

Ozone is highly unstable and reactive.

Avoid contact with alkanes, ethylene, diethyl ether, nitrogen tetroxide, bromine, hydrogen bromide, bromhidric acid, nitro-glycerine.

HANDLING AND STORAGE

The ozone must be contained in gas resistant pipes and the ducts must branch off the generation point to the application point without leaks.





In case of leaks, turn off the ozone generator and ventilate the area.

Evacuate the area until the ozone levels return within the first tolerable parameters (0.11 ppm).

DISPOSAL

The gas must be reduced to less than 0.1 ppm before it can be dispersed in the water, ground or atmosphere.

HAZARD IDENTIFICATION

	H270: It may cause or worsen a fire.
	H15: It causes skin irritation. H319: It causes severe eye irritation.
	H330: Fatal if inhaled. H335: It can irritate the respiratory tracts.
	H373: It can cause damage to bronchi and lungs if inhaled for a long period of time or repeatedly.
	H400: Highly toxic for aquatic organisms.

6 FUNCTIONING OF THE RADIO DEVICES

Wireless connection with Bluetooth® technology

The wireless connectivity with Bluetooth technology is a technology that supplies a standard and reliable method to exchange information between different devices, using radio waves. Other than TEXA products, even products such as cellular phones, portable devices, computers, printers, cameras, pocket PCs etc. use this type of technology.

The Bluetooth interface searches for compatible electronic devices according to the radio signal they generate and establishes a connection between them. TEXA tools operate a selection suggesting only TEXA compatible devices. This does not exclude the presence of other sources of communication or disturbance.

THE EFFICIENCY AND THE QUALITY OF THE BLUETOOTH COMMUNICATION MAY BE INFLUENCED BY THE PRESENCE OF RADIO DISTURBANCE SOURCES. THE COMMUNICATION PROTOCOL HAS BEEN DEVELOPED TO MANAGE THESE TYPES OF ERRORS; HOWEVER, IN THESE CASES COMMUNICATION MAY BECOME DIFFICULT AND CONNECTION MAY REQUIRE SEVERAL ATTEMPTS.

SHOULD THE WIRELESS CONNECTION ENCOUNTER SERIOUS PROBLEMS THAT MAY COMPROMISE A REGULAR COMMUNICATION, THE SOURCE OF THE ENVIRONMENTAL ELECTROMAGNETIC DISTURBANCE MUST BE IDENTIFIED AND ITS INTENSITY REDUCED.

Position the product in order to guarantee the correct functioning of its radio devices. In particular, do not cover it with any shielding or metallic materials in general.

7 ENVIRONMENTAL INFORMATION



Do not dispose of this product with other undifferentiated solid waste.
For information regarding the disposal of this product please see the pamphlet supplied.

8 NORMATIVE INFORMATION

Simplified EU Declaration of Conformity

	<p>The manufacturer, TEXA S.p.A., declares that the type of SANITIZER SNT-O3 radio equipment is compliant with the following directives:</p> <ul style="list-style-type: none">• <i>RED 2014/53/UE & 2015/863/EU</i> <p>The complete text of the EU declaration of conformity is available at the following Internet address http://www.texa.it/download.</p>
---	--

9 SANITIZER SNT-O3

SANITIZER SNT-O3 is a device expressly designed and manufactured for the sanitation of environments capable of operating in *stand-alone* mode in environments (vehicles or rooms) up to 12 m³

SANITIZER SNT-O3 is able to sanitise environments up to 120 m³ when combined with a computerised display unit complete with a specific software app for managing the sanitation.



SANITIZER SNT-O3 is activated directly from outside the environment that must be sanitised through:

- *the radio control provided (stand-alone mode)*
- *free app that can be downloaded from **Google Play** or **App Store***
- *TEXA's specific IDC5 diagnostic software app.*

The passenger compartment sanitation procedure is completely automatic: **SANITIZER SNT-O3** is equipped with ozone, humidity and temperature sensors thanks to which it is capable of evaluating autonomously the correct level of ozone saturation inside the passenger compartment.

Furthermore, **SANITIZER SNT-O3** is equipped with a dust filter at intake that prevents the passage of particles towards the ozone generator, making it efficient and safe.

The dust filter also guarantees a longer life for the ozone generator and eliminates the risk of an accidental production of nitric acid that may generate due to the entry of particulate matter into the oxygen/ozone transformation chamber.

The app and software allow you to follow all the sanitation phases and generate a PDF document that can be printed and certifies that the sanitation was completed.

10 OPERATION

Before describing the operation of SANITIZER SNT-O3, it is useful to have a basic knowledge of the ozone:

- *it is the most powerful bactericide and virustatic in nature that can be used;*
- *it bactericidal action is based on its high direct oxidation capacity thanks to which the microorganisms (bacteria, viruses, mildew, fungi, yeasts, algae, etc.) are destroyed or inactivated through a quick and definitive action without producing toxic sub-products.*
- *it is capable of reducing the percentage of metals (e.g. mercury, arsenic, etc.), pesticides (e.g. atrazine, propazine, etc.), polluting elements (e.g. hydrocarbons, surfactants, etc.) and many other toxic substances in water, air, food.*
- *the concentration of ozone must be at least 0,6 ppm and stay stable for a minimum of 20 minutes so it can inactivate possible viruses in the passenger compartment.*
- *its efficiency is strongly influenced by air humidity: the higher, the more it is efficient, especially on porous surfaces (carpet fabrics for example).*
- *the time for halving the amount of ozone in the environment is approximately 72 hours.*
- *based on the European regulations, exposure to the ozone in the environment cannot exceed 0,1 ppm and must be limited to 8 hours.*
- *it connects with NO_x type gases and can generate potentially toxic compounds such as (e.g. nitric acid, HNO₃).*
- *it eliminates any type of odour.*
- *it is a powerful bleach on some materials.*

Below the sanitation phases are described.

PHASE 1: OZONE GENERATION

During this phase, SANITIZER SNT-O3 uses its ozone, temperature and humidity sensors and the volumetric setting provided by the operator via radio control or app to optimise the generation of ozone.

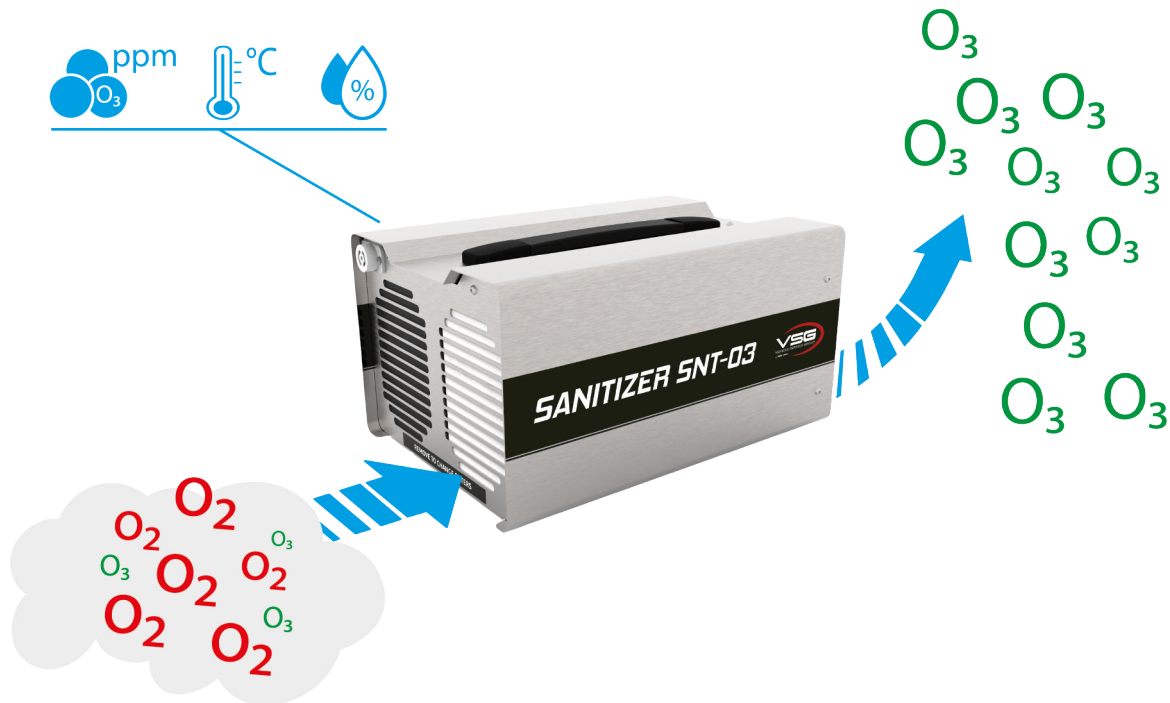

SANITIZER SNT-O3 draws the air in the passenger compartment or in the room through a dust filter.

The dust filter has a double function:

- *it reduces the risk of accidental production of toxic components (e.g. nitric acid) caused by the entry of particles in the ozone generator;*
- *guarantees a longer life to the ozone generator.*

The air filtered this way passes through the ozone generator and is then input into the environment that must be sanitised.

For the generation of the ozone, SANITIZER SNT-O3 uses the corona discharge technology on a borosilicate hose that allows generating 10 g/h if pure oxygen is input into the hose's inlet.

When SANITIZER SNT-O3 is being used, the generator produces an amount of ozone that is lower than its maximum capacity but however sufficient for a proper sanitation.

This allows avoiding overheating and guaranteeing a higher average lifetime to the generator itself.

PHASE 2: RETENTION OF THE OZONE CONCENTRATION

SANITIZER SNT-O3 uses the ozone sensor and the volume selected during the start-up phase to make sure the level of the saturation of gases stays sufficiently high the whole time needed to guarantee a proper sanitation.

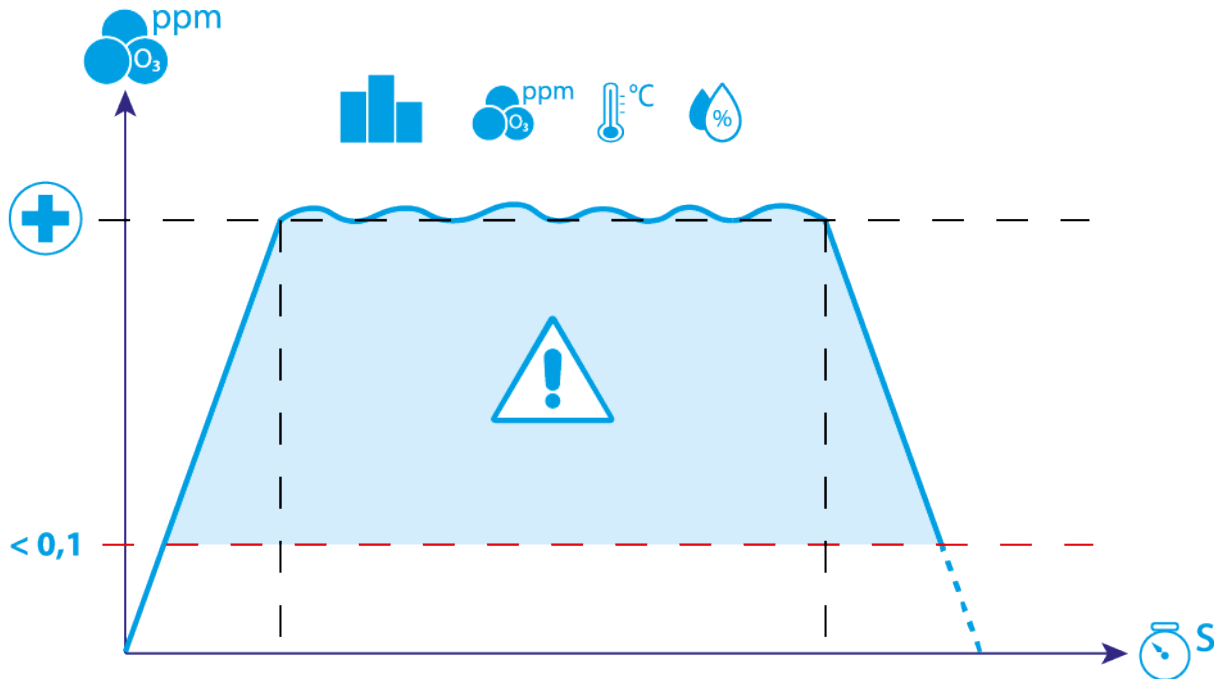

This allows exceeding the limits (concentration of ozone not enough to sanitise the environment) and avoid risks (concentration of ozone too high and attacks plastic parts and fabrics) deriving from the use of solutions based merely on timing.

PHASE 3: CONVERSION OF THE EXCESS OZONE INTO OXYGEN:

This phase is directed to bring the percentage of ozone in the environment within the safety limits avoiding the risk of intoxication connected with an insufficient aeration before returning the vehicle.



SANITIZER SNT-O3 draws the saturated air in the passenger compartment.

The intake air is filtered through a specific filter that reconverts the ozone into oxygen.

SANITIZER SNT-O3 uses the ozone sensor to make sure the concentration of ozone has been reduced to at least the safety level require by the law in force.

11 DESCRIPTION

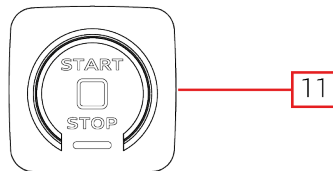
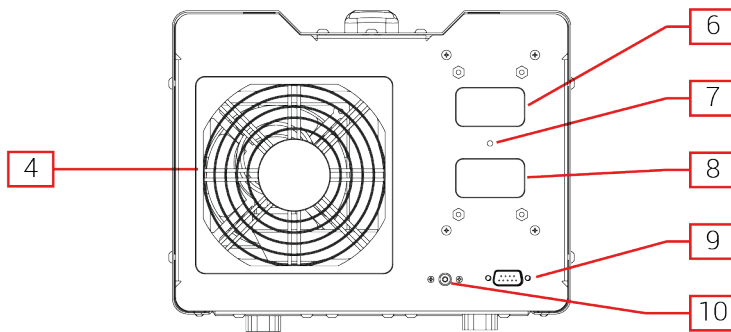
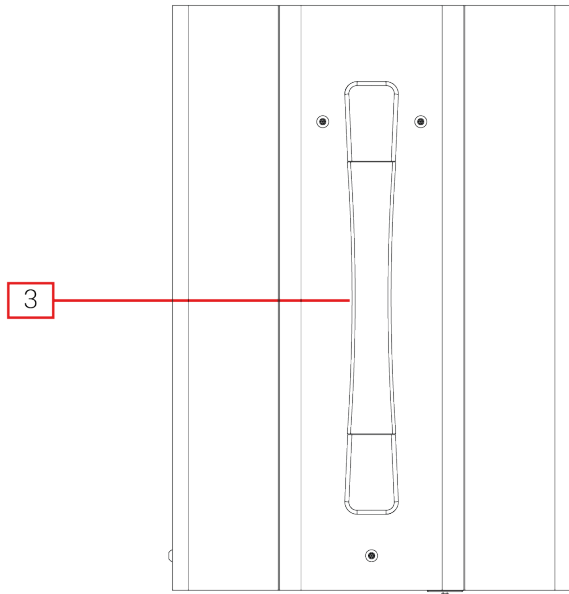
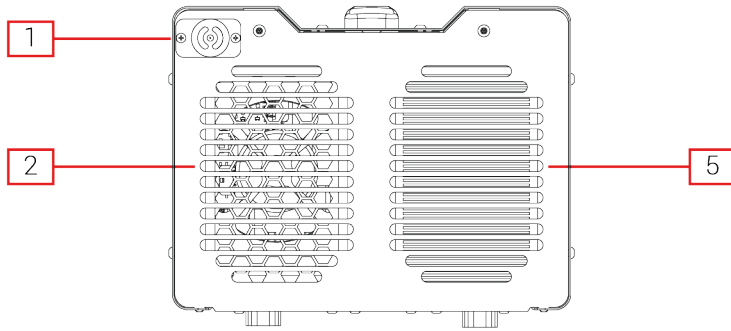

- 1. Ozone sensor
- 2. Fan and active carbon filter
- 3. Handle
- 4. Ozonated air outlet
- 5. Fan and anti-dust filter
- 6. LED
- 7. Humidity and temperature sensors
- 8. Bluetooth
- 9. RS232 *
- 10. 12 V connector
- 11. Radio control **

(*) Reserved for assistance type operations.

(**) The radio control is equipped with its own LEDs and a buzzer.

12 TECHNICAL FEATURES

12.1 Sanitiser

Manufacturer:	TEXA S.p.A.
Product name:	SANITIZER SNT-O3
Brand:	RAVAGLIOLI S.p.A.
Main processor:	<ul style="list-style-type: none"> • <i>Type: Cortex M0</i> • <i>RAM: 32 KN</i> • <i>Mass Storage: 256 KB</i>
Power supply connector:	2.5 DC jack
Power supply:	<ul style="list-style-type: none"> • <i>12 Vdc *</i> • <i>120 - 240 V, 50 - 60 Hz **</i> <p><i>(*) from cigar lighter socket with TEXA wiring code 3911086</i></p> <p><i>(**) from optional charger:</i></p> <ul style="list-style-type: none"> • <i>MEANWELL GST90A12-P1M</i> • <i>100-240VAC, 50/60 Hz</i>
Insulation class:	Class II (double insulation)
Power / Absorption:	max 80 W @ 12 V
Serial connector:	DB9 <i>Reserved for assistance type operations</i>
Bluetooth communication:	BLE 4.2
Operational band:	2400 ÷ 2483.5 MHz
Maximum radio frequency power transmitted:	< 5 dBm
User interface:	Red LED and green LED for operation warnings, alarms, maintenance
Start/stop remote control:	Bluetooth radio control and Android/iOS app
O₃ generation capacity:	10 g/h * <i>(*) in pure oxygen</i>
Fan airflow volume:	200 m ³ /h
O₃ generation chamber:	Borosilicate glass
Type of operation:	Automatically controlled saturation
Sensors:	<ul style="list-style-type: none"> • <i>Ozone</i> • <i>Temperature</i> • <i>Humidity</i>
Intake air treatment filter:	Dust filter (dust filter)
O₃ --> O₂ transformation:	Active carbon filter
Noisiness:	< 80 dB(A)

Operating temperature:	0 ÷ 50 °C
Storage temperature:	- 20 ÷ 60 °C
Operating moisture:	10% ÷ 80% without condensation
Dimensions:	370x252x192 mm
Weight:	6000 g
Ministerial regulations:	Prot. n.24482 31/07/1996 CNSA 27/10/2010
Directives:	RoHS 2011/65/UE RED 2014/53/UE 2015/863/UE
Electromagnetic compatibility:	ETSI EN 301 489-1 ETSI EN 301 489-17
Radio systems:	ETSI EN 300 328
Electrical safety:	IEC/EN 60335-1 + AMD EN 62311:2008
Data plate:	

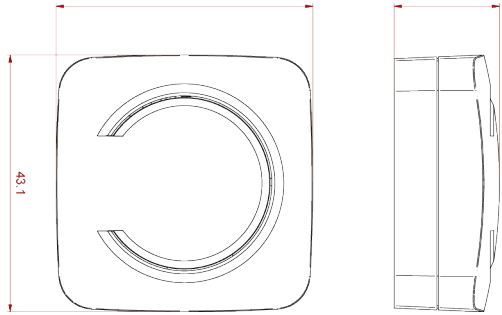
Manufacturer:	TEXA S.p.a.
Model:	TMD MK3 PRIVACY BTLE
CPU:	Cypress PSOC
Communication:	Bluetooth Low Energy
Visible warnings:	Green LED and red LED
Audible warnings:	Built-in electronic buzzer
Internal Cell:	CR2450 cell
Consumptions:	26 μ A in standby
Storage and operating humidity:	10% ÷ 80 % without condensation.
Operating temperature:	- 20 ÷ 50 °C
Storage temperature with battery cell disconnected:	- 30 ÷ 70 °C
Dimensions [mm]:	
Weight:	12 g
Directives:	RED 2014/53/EU RoHS 2011/65/EU & 2018/863/EU
Electromagnetic compatibility:	ETSI EN 301 489-1 ETSI EN 301 489-17 ETSI EN 300 328 EN 62479:2010
Safety:	EN 60950-1:2006 + A11:2009 + A1:2010 + A12:2011 + AC:2011 + A2:2013

13 POWER SUPPLY

SANITIZER SNT-O3 does not have an internal battery and can be powered:

- *by the battery in the vehicle being tested using an appropriate wiring connected to the cigar lighter;*
- *from the mains through a specific charger (optional).*

NOTICE

The use of different power sources other than the ones indicated in this manual can damage SANITIZER SNT-O3.

Do not power SANITIZER SNT-O3 with external batteries that are not electrically connected to the vehicle being sanitised.

13.1 Cigar lighter cable

SANITIZER SNT-O3 can also be powered by the battery in the vehicle being tested using the 12 V. connector.

CAUTION

The use of different power cables other than the one provided can damage SANITIZER SNT-O3 and expose the operator to the risk of injuries.

Only use the cable provided (code 3911086).

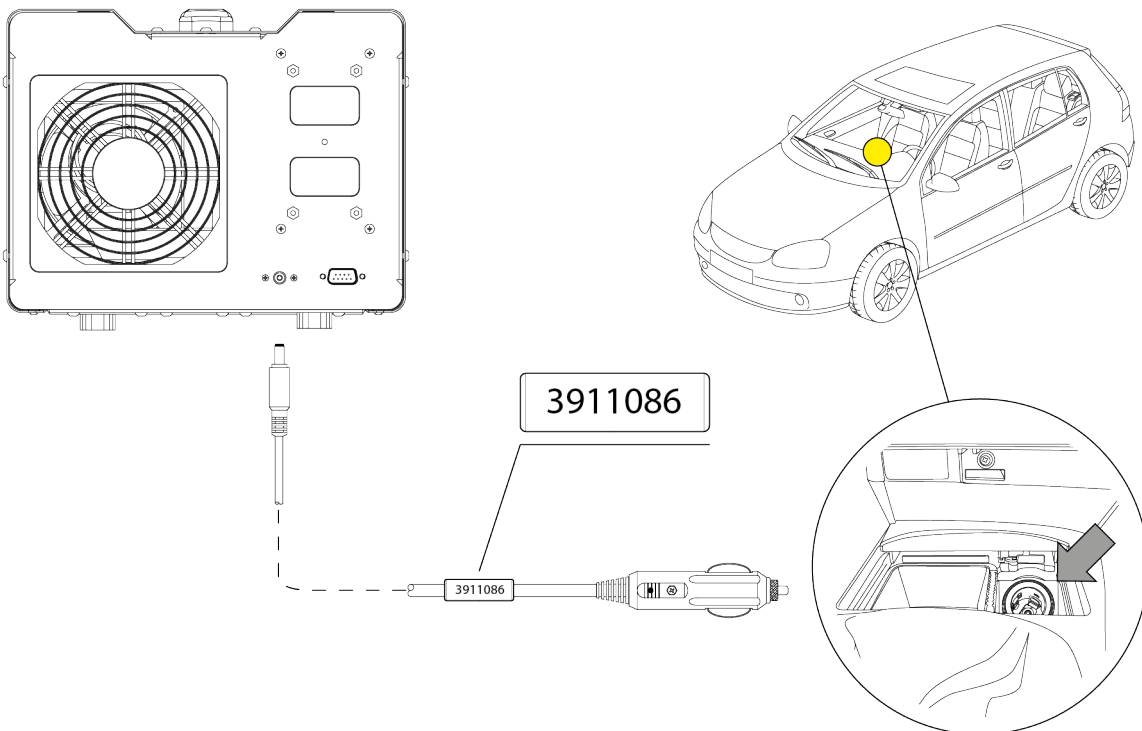

NOTICE

The image is only an example: the position of the cigar lighter socket may change based on the vehicle being tested.

Always refer to the documentation supplied by the vehicle manufacturer for the positioning and correct access to the cigar lighter socket.

NOTICE

Make sure the cigar lighter socket is powered even when the ignition key is on OFF (instrument panel off).

Proceed as follows:

1. Connect the cigar lighter cable to the **12 V** connector.
2. Connect the cigar lighter cable to the cigar lighter socket in the vehicle being tested.

The green LED on the connector for the cigar lighter socket turns on.

The green LED and the red LED on SANITIZER SNT-O3 flash 5 times, then the red LED stays on.

13.2 Power Supply from the Mains

SANITIZER SNT-O3 can be powered directly by the mains using a specific charger (optional).

CAUTION

The use of different chargers other than the one indicated can damage SANITIZER SNT-O3 and expose the operator to the risk of injuries.

Only use the charger:

- **Model: GST90A12-P1M**
- **Code:3911049**

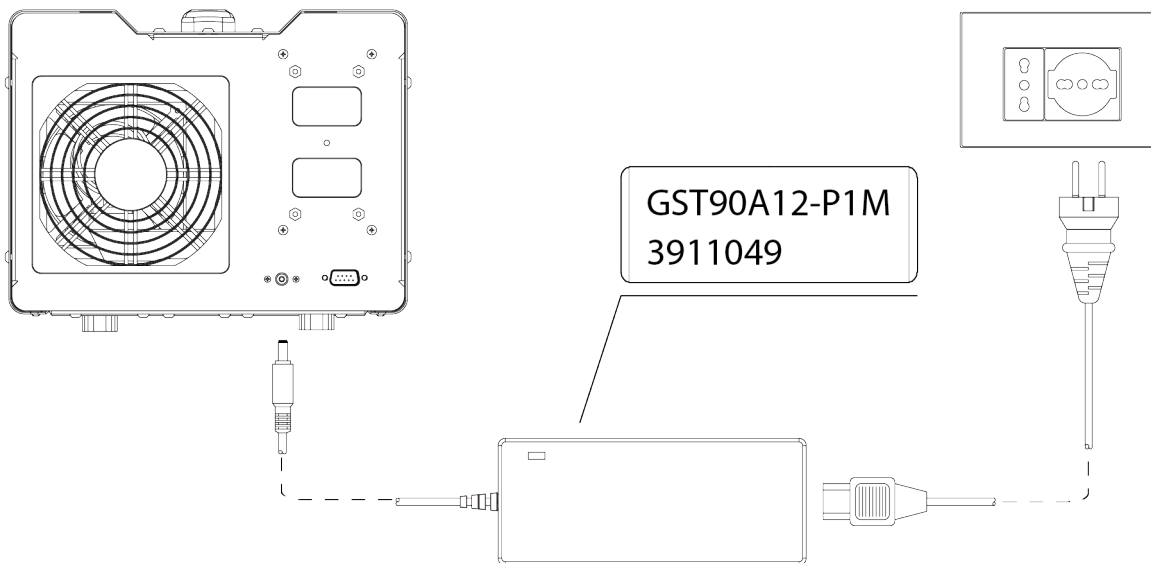

Proceed as follows:

1. Connect the power cable to the charger.
2. Connect the charger's cable to the **12 V** connector.
3. Connect the charger to a power socket.

The green LED and the red LED on SANITIZER SNT-O3 flash 5 times, then the red LED stays on.

14 POWER ON/OFF

SANITIZER SNT-O3 turns on automatically once it is connected to one of the power sources described previously.

CAUTION

If the LEDs on SANITIZER SNT-O3 do not work properly the operator may not be warned promptly in case of a fault.

Make sure the warning LEDs work properly each time you turn on the device, that is each time you connect SANITIZER SNT-O3 to the power source.

For further information, see the USE chapter.

At start-up the green LED and red LED flash 5 times alternately.

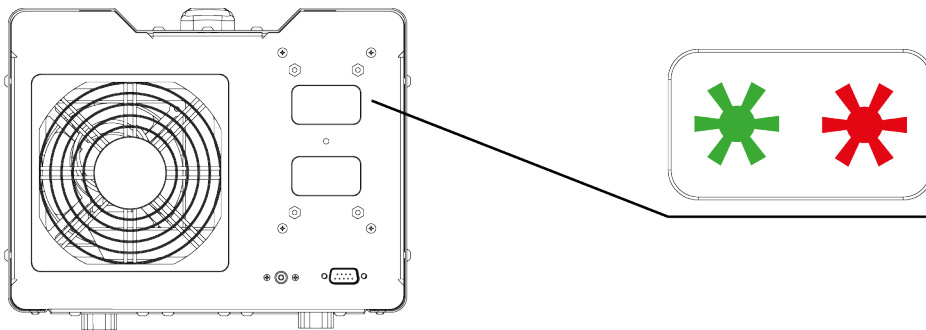

Then, SANITIZER SNT-O3 awaits commands and signals its status by keeping the red LED on.

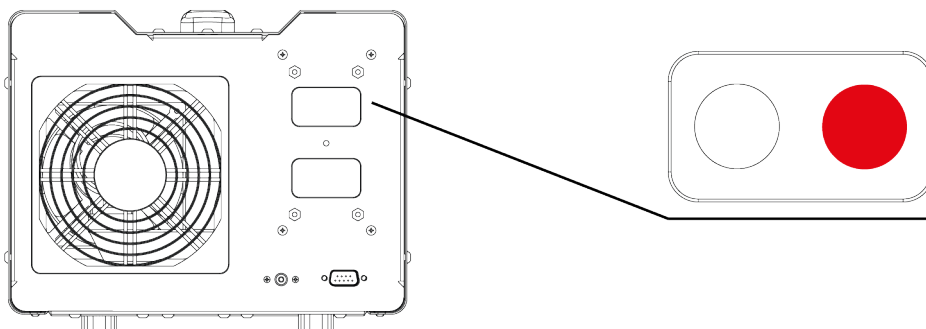

INFORMATION

If, upon activation, there is a fault or a programmed maintenance operation must be performed, SANITIZER SNT-O3 replaces the red LED fixed on with an appropriate warning. For further information see the NOTIFICATIONS VIA LED chapter.

The device is ready to begin the sanitation.

For further information see the POWER SUPPLY chapter.

To turn off SANITIZER SNT-O3 you must disconnect it from the power source.

15 COMMUNICATION

SANITIZER SNT-O3 communicates with the provided radio control and with the display unit via Bluetooth.

The display unit with which SANITIZER SNT-O3 can communicate are:

- *smartphone**
- *AXONE NEMO ***
- *AXONE NEMO 2 ***

(*) *After installing the specific app.*

(**) *TEXA S.p.A. product.*

INFORMATION

To optimise the Bluetooth communication between SANITIZER SNT-O3 and the radio control or display unit, we recommend standing at a close distance (e.g. near the vehicle windows) when the sanitiser is inside a vehicle or an environment that must be sanitised.

SANITIZER SNT-O3 communicates with one device (radio control or display unit) at a time. For example: you cannot use the radio control if SANITIZER SNT-O3 is connected with a smartphone.

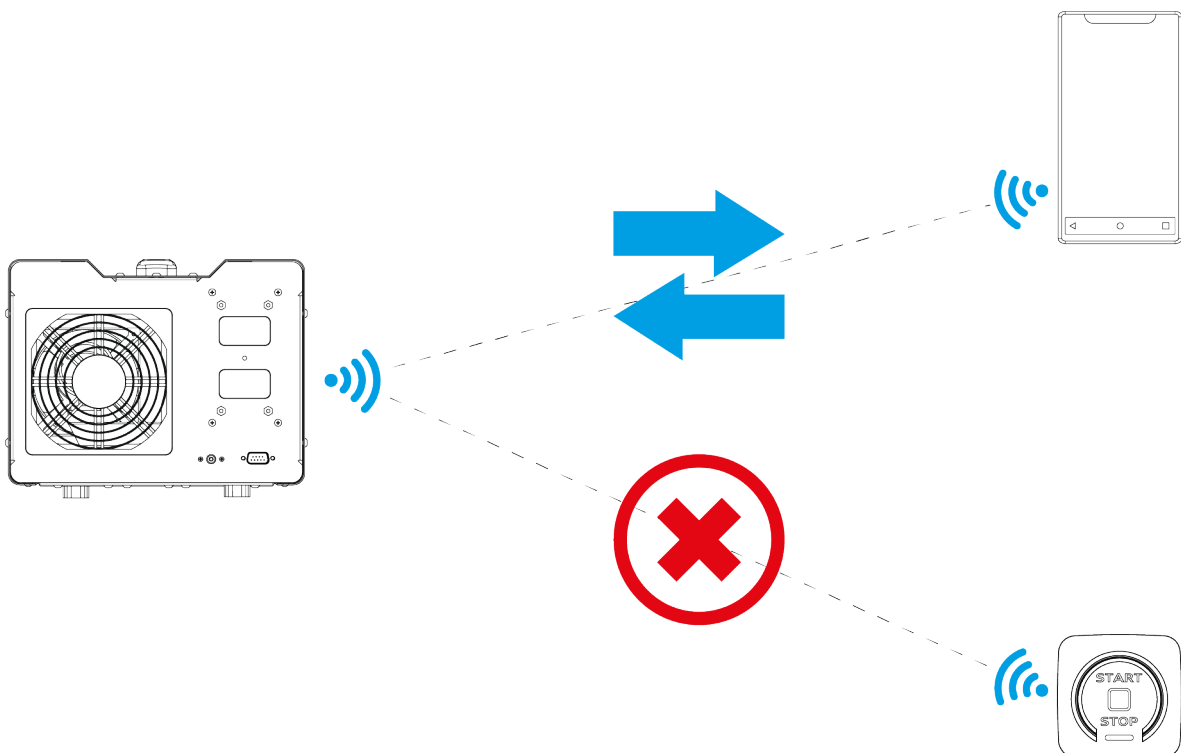

In this case, to use the radio control, you must first interrupt the communication with the smartphone, for example by closing the app or deactivating the Bluetooth.

INFORMATION

It is impossible with to communicate with SANITIZER SNT-O3 through a serial cable.

The tool's serial connector RS232 is reserved for assistance type operations.

15.1 Radio control

The configuration of the communication between the radio control and SANITIZER SNT-O3 is automatic when the radio control is used for the first time.

INFORMATION

For a proper configuration of the communication between the radio control and SANITIZER SNT-O3 the following conditions are required:

- the battery must be inserted in the radio control;
- only one SANITIZER SNT-O3 at a time can be on;
- SANITIZER SNT-O3 must not already be communicating with a display unit (e.g. smartphone).

Proceed as follows:

1. Power SANITIZER SNT-O3
2. Wait until the red LED on SANITIZER SNT-O3 stays on.
3. Press the button on the radio control.

The built-in buzzer emits 1 beep.

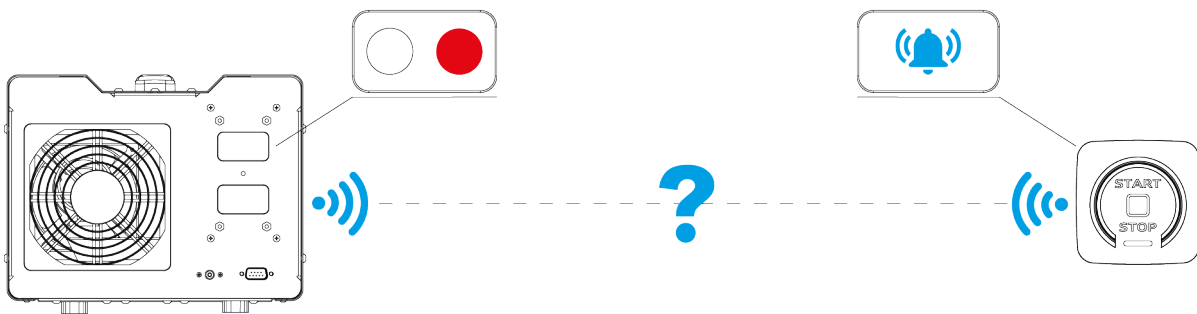

If the configuration was successful, the radio control starts the blink cycle related to the selection of the volume of the environment that must be sanitised.

For further information see the RADIO CONTROL: COMMANDS AND NOTIFICATIONS chapter.

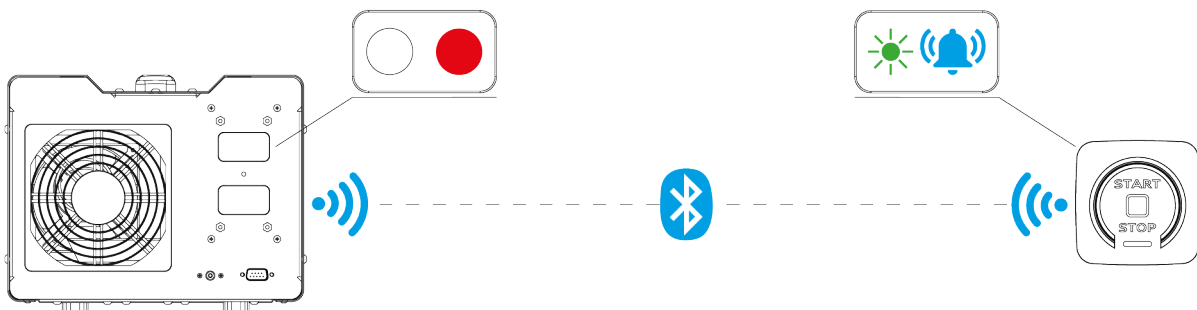

If the configuration was not successful, the red LED on the radio control flashes 3 times and the buzzer emits an extended beep.

If needed, you can delete the radio control - SANITIZER SNT-O3 pairing.

Proceed as follows:

1. Hold the button for more than 5 seconds then release it.

The green LED on the radio control flashes twice and 2 long beeps are emitted.

15.2 Display Unit

The communication between SANITIZER SNT-O3 and the display unit must be configured through the specific software function before any type of operation.

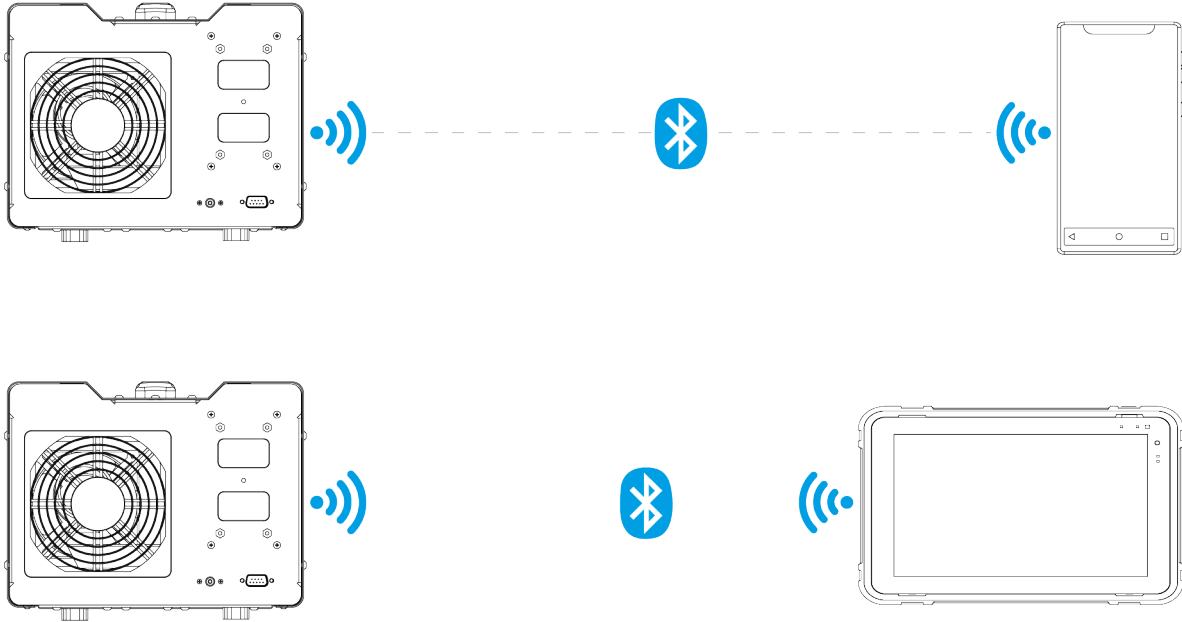

INFORMATION

Make sure the Bluetooth is active before starting the configuration of the communication between SANITIZER SNT-O3 and the smartphone.

INFORMATION

To configure the communication properly you must use the serial number indicated on the data plate on SANITIZER SNT-O3.

Proceed as follows:

1. *Power SANITIZER SNT-O3.*
2. *Turn on the display unit.*
3. *Launch the app or diagnostic software.*
4. *Launch the communication configuration function.*
5. *Follow the instructions that appear on screen.*



For further information see the software operating manual.

16 RADIO CONTROL: COMMANDS AND NOTIFICATIONS

The radio control allows using SANITIZER SNT-O3 without the need for a display unit.

INFORMATION









Using the radio control allows sanitising environments (vehicles, rooms, etc.) up to a maximum volume of 12 m³.

Beyond 12 m³ and up to 120 m³ SANITIZER SNT-O3 must be used via app or software.

The use of the radio control to sanitise environments (vehicles, rooms, etc.) with a volume above 12 m³ may compromise the efficiency of the sanitation procedure.

The radio control sends a different command to SANITIZER SNT-O3 based on how long the button is pressed.



























The transmission of each command is followed by specific acoustic and light notifications through the radio control's buzzer and LEDs.

Command	Pressure	Warning
start the communication between the radio control and SANITIZER SNT-O3	short (less than 5 seconds)	
select the volume of the environment that must be sanitised		It depends on the volume selected. See: <i>Volume Selection</i>
stop the sanitation procedure		
delete the Bluetooth pairing between the radio control and SANITIZER SNT-O3 ¹	extended (more than 5 seconds)	 +  x2* (* <i>Blink and long beeps</i>)
confirm filter replacement ²	long (more than 15 seconds)	  * +    <i>Alternated flashing for 3 seconds.</i>



⁽¹⁾ For further information see the *COMMUNICATION* chapter.

⁽²⁾ For further information see the *MAINTENANCE* chapter.

Other than the commands, a series of warning are also provided:

Warning	Warning
confirm command received correctly by SANITIZER SNT-O3	 + 
programme maintenance warning ²	 +      See: <i>Programmed Maintenance Warning</i>
battery low	The orange LED flashes instead of the green LED in all the notifications. If the battery's charge is less than 10%, you will receive the error notification when you press the button.
error	   +  [*] 3 second beep
self-test (after battery replacement)	          +     then  [*] (*) flashing for 60 seconds, then standby

⁽²⁾ For further information see the MAINTENANCE chapter.

-  = flashing green LED.  = flashing red LED.
-  = beep.

16.1 Volume Selection

After starting the communication with SANITIZER SNT-O3, the radio control allows selecting the volume of the environment that must be sanitised choosing among:

- 2 m³
- 4 m³
- 8 m³
- 12 m³

Each volume is identified by a specific notification of the green LED and red LED.







The selection is made by pressing the button with the first 3 seconds following the notification related to the desired volume.

INFORMATION

If the button is pressed while it is flashing, the command is ignored.

If the pressure is extended, the sanitation start command is sent automatically.

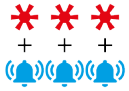
After pressing the button, the radio control confirms it received the selection and starts the sanitation procedure.

Warning	Volume m ³	Selection waiting time	Selection received confirmation
	2 m ³	3 s	
	4 m ³		
	8 m ³		
	12 m ³		

 = flashing red LED.  = flashing green LED.
 = beep.

INFORMATION

The radio control repeats the complete blink cycle (from 1 to 4) twice.

If during this period of time no selection is made, the radio control goes into standby mode.

Example: selection of the correct volume to sanitise a room of approximately 7 m³

1. Press the button.

The button gives the notification: 

+ + +

2. Wait for the notification: 

3. Press the button within 3 seconds from the last blink.

+ + +

4. The button gives the notification: 

8 m³ was selected for the sanitation procedure.



SANITIZER SNT-O3 starts the sanitation procedure.

16.2 Programmed Maintenance Warning

The radio control uses a specific notification to warn of the need to carry out the following programmed maintenance operations in the short term:

- *filter replacement*
- *ozone sensor replacement*
- *ozone generator replacement*

The notification is:

 +  = the red LED flashes for a long time and 5 close beeps are emitted.

The radio control shows this notification immediately after the volume selection.

After the notification, the radio control goes into standby mode and the sanitation procedure does not start.

At this point the button can be pressed again and the volume desired can be reselected.









The sanitation procedure will be started normally if SANITIZER SNT-O3 was not turned off in the meanwhile.

INFORMATION

The notification is shown again each time SANITIZER SNT-O3 is turned on until the maintenance operation is carried out and confirmed.

17 NOTIFICATIONS VIA LED

SANITIZER SNT-O3 uses the LEDs with which it is equipped to provide several information:

Warning	Meaning
 * (*) <i>Simultaneous flashing</i>	Power on (connection of SANITIZER SNT-O3 to the power supply)
	Awaiting commands
	Sanitation in progress
	Sanitation completed successfully
 * (*) <i>Quick flashing</i>	Filter replacement request warning ¹
 * (*) <i>Quick simultaneous flashing</i>	Ozone sensor or ozone generator replacement request warning ¹
 * (*) <i>Fixed on for 10 seconds</i>	Filter replacement done ²
 * (*) <i>Quick flashing</i>	Failure

 = red LED fixed on.  = flashing red LED.

 = green LED fixed on.  = flashing green LED.

⁽¹⁾ For further information see the MAINTENANCE chapter.

⁽²⁾ The replacement is confirmed by pressing the button (more than 15 seconds).

! WARNING

The ozone is toxic and irritating mainly for the respiratory tracts (concentration > di 0.3 ppm), slightly for eyes and rarely for the skin.

Extended exposure can cause severe injuries.

To avoid these injuries, you must:

- follow the safety measures indicated in the SAFETY RULES chapters;
- carry out the preliminary checks before starting the sanitation;
- follow the operating procedure;
- carry out the checks when the sanitation is complete.

In particular:

- do not proceed with the sanitation procedure if even only one of the preliminary checks gave a negative result;
- do not leave the device connected to the power supply if it will not be used immediately;
- when possible, always disconnect the device from the power supply after using it.

NOTICE

The ozone is highly reactive.

An extended and repeated exposure to high concentrations of ozone may cause a bleaching action on plastic parts and fabrics and oxidise metal and plastic components.

Do not repeat the sanitation several times within a short range of time.

INFORMATION

Exposure to the high percentages of ozone needed for the sanitation of the environments may oxidise the device's stainless steel chassis; however, this will not compromise its proper operation.

Please remember the definition of "environment" within this manual:

- **Environment:** *any compartment in a vehicle (e.g. passenger compartment, boot, etc.), dedicated to the transportation of people, animals, plants or goods, including containers of a maximum size of 120 m³; any closed space, dedicated to the use by people (e.g. hotel room) or to the storage of goods (e.g. warehouse) of a maximum size of 120 m³.*

18.1 Preliminary Checks Before the Sanitation

Before starting the sanitation procedure, you must make sure that:

- *inside the environment that must be sanitised there are no:*
 - *living beings;*
 - *peeled cable that may produce sparks;*
 - *overheated elements that may trigger combustions (e.g. electronic lighters with filament or still warm);*
 - *free flames of any type (e.g. cigarette butts still lit, candles);*
- *all the air entries in the environment (e.g. windows, doors, liftgate, panoramic sunroof, convertible top, etc.) are closed;*
- *SANITIZER SNT-O3 and its removable parts are intact (e.g. power cable);*
- *there are not any visible obstructions in the grilles that protect the filters and fans;*
- *the filters and sensors that must be replaced periodically have not reached their lifetime limit;*
- *the A/C system is off;*
- *the vehicle's parking brake is engaged.*

INFORMATION

Poor air tightness of the environment that must be sanitised (e.g. faulty seals, door or window open, etc.) can compromise the efficiency of the sanitation procedure.

SANITIZER SNT-O3 cannot detect air leaks in the environment that must be sanitised.

The operator must make sure the environment that must be sanitised has a good airtightness.

18.2 Sanitation

The sanitation of the environment and the restoration of the correct concentration of oxygen and ozone are completely automatic.

Starting and interrupting the sanitation procedure can be controlled either using the radio control or through the app or software.

For further information on how to use SANITIZER SNT-O3 through the app or software see the APP AND SOFTWARE chapter.

The operating procedure using the radio control (*stand-alone* mode) is indicated below.

Proceed as follows:

1. Position SANITIZER SNT-O3 inside the environment that must be sanitised:

- *near the power source;*
- *on a flat surface from which it cannot fall;*
- *so that there is at least half a metre of distance between the fans and walls;*

INFORMATION

When sanitising a vehicle, we recommend positioning SANITIZER SNT-O3 inside the passenger compartment.

If SANITIZER SNT-O3 is placed in the boot, be sure to remove or retract the parcel shelf.

2. Power SANITIZER SNT-03.

The green LED and the red LED on SANITIZER SNT-03 flash 5 times.
Then the red LED stays on.

INFORMATION

If using SANITIZER SNT-03 on a vehicle:

- *power SANITIZER SNT-03 using the cigar lighter cable;*
- *keep the engine running throughout the entire sanitation procedure;*
- *maintain the internal recirculation air with the fan set on its minimum speed and at a temperature of approximately 23 °C throughout the entire sanitation procedure.*

If using SANITIZER SNT-03 in a room:

- *power SANITIZER SNT-03 using a mains power adapter.*

3. Exit from the environment that must be sanitised.

4. Place the provided sanitation in progress warning notification on the entries of the environment so that they are clearly visible.

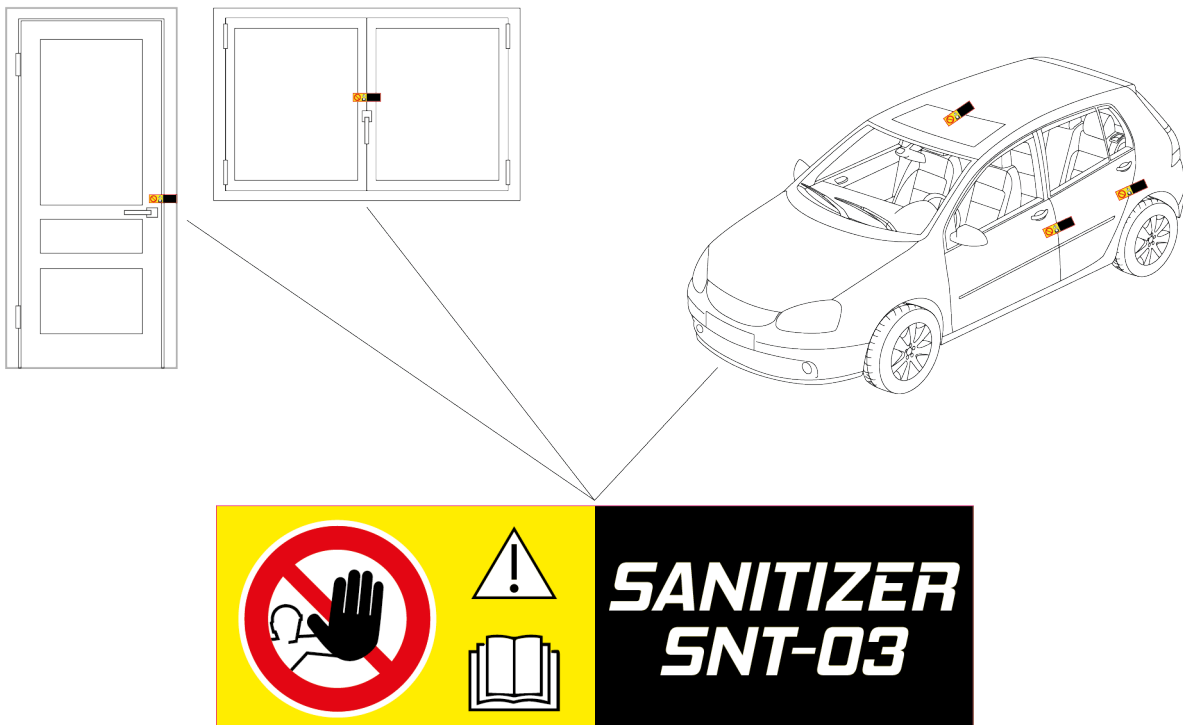

5. Press the button on the radio control and select the volume of the environment that must be sanitised.

The red LED on SANITIZER SNT-03 starts flashing.
SANITIZER SNT-03 starts the sanitation procedure.

6. Wait for the sanitation procedure to complete.

At the end of the sanitation procedure SANITIZER SNT-O3 stops and this is indicated on SANITIZER SNT-O3 by the red LED that turns off and the green LED on that turns on.

7. Aerate the environment for a few minutes (e.g. open the doors, liftgate, etc.).

8. Access the sanitised environment wearing the appropriate PPE.

9. Remove the power supply from SANITIZER SNT-O3.

10. Remove SANITIZER SNT-O3 from the sanitised environment.

18.3 Post-Sanitation Checks

At the end of the sanitation procedure, you must make sure that:

- *SANITIZER SNT-O3 and its removable parts are intact (e.g. power cable);*
- *there are not any visible obstructions in the grilles that protect the filters and fans.*

19 EMERGENCY SHUTOFF

The sanitation procedure can be interrupted at any time even in on of the following ways:

- *by pressing the button on the radio control;*
- *by pressing the specific icon in the app or software.*

INFORMATION

Closing the software app or software does not stop the sanitation procedure.

Follow the procedure indicated below.

SANITIZER SNT-O3 automatically stops the sanitation procedure in case of a fault or malfunction.

The error is indicated by the quick flashing of the red LED on SANITIZER SNT-O3 and through specific messages in the display unit.

Proceed as follows:

1. *If necessary, interrupt the sanitation procedure using the radio control, app or software.*
2. *Carefully open one or more openings on the environment (e.g. doors).*
3. *Aerate the environment for at least 30 minutes.*
4. *Access the environment wearing an appropriate protective mask.*
5. *Remove the power supply from SANITIZER SNT-O3.*
6. *Remove SANITIZER SNT-O3 from the sanitised environment.*
7. *Contact Technical Assistance.*

20 APP AND SOFTWARE

The use of SANITIZER SNT-O3 in combination with a smartphone in which the specific app is installed offers a series of additional functions that are not available using only the radio control.

Other than starting and interrupting the sanitation procedure, thanks to the app you can:

- *view which phase of the sanitation procedure is in progress;*
- *monitor parameters such as:*
 - *temperature*
 - *humidity*
 - *time remaining until the end of the sanitation procedure*
- *view the time remaining until the filters need to be replaced;*
- *receive warnings in case of malfunctions.*

Specific functions are also available, such as:

- *generate a PDF document that can be printed and that certifies that the vehicle was sanitised properly;*
- *indicate a reference value for the volume of the environment that must be sanitised, a vehicle or hotel room, in order to optimise the sanitation procedure;*
- *plan the sanitation procedure at a preset time, for example to sanitise an environment while it is not being used.*

WARNING

In case of a delayed start of the sanitation procedure, the procedure and safety indications indicated in the USE chapter must always be followed.

In an automotive environment, in addition to the functions offered by the app, the use of SANITIZER SNT-O3 in combination with a TEXA display unit and VCI (Vehicle Communication Interface) allows performing operations such as:

- *the activation of the air recirculation;*
- *the activation of the fan;*
- *the deactivation of the A/C system.*

INFORMATION

The possibility to take advantage of certain resources in the diagnostic software depends on the vehicle that is being work on.

INFORMATION

Poor air tightness of the environment that must be sanitised (e.g. faulty seals, door or window open, etc.) can compromise the efficiency of the sanitation procedure.

The app and software are able to determine the best sanitation strategy automatically; however, they cannot detect possible air leaks in the environment that must be sanitised.

The operator must make sure the environment that must be sanitised has a good airtightness.

INFORMATION

Beyond 12 m³ and up to 120 m³ SANITIZER SNT-O3 must be used via app or software.

The use of the radio control to sanitise environments (vehicles, rooms, etc.) with a volume above 12 m³ may compromise the efficiency of the sanitation procedure.

20.1 Firmware Update

The firmware in SANITIZER SNT-O3 is updated through a specific software function and requires the connection to a display unit.

INFORMATION

Regardless of the type of display unit, during the update:

- *do not turn off SANITIZER SNT-O3;*
- *do not turn off the display unit;*
- *do not interrupt the communication between SANITIZER SNT-O3 and the display unit.*

Proceed as follows:

1. *Power SANITIZER SNT-O3.*
2. *Open the app/start the diagnostic software.*
3. *Access the firmware update function.*
4. *Follow the instructions that appear on screen.*



For further information, see the software operating manual.

21 MAINTENANCE

You must carry out the maintenance operations for SANITIZER SNT-O3 to work properly and safely.

NOTICE



Failure to maintenance the device properly may cause it to malfunction.

It is the operator's responsibility to perform the proper maintenance on the device based on what is indicated in this manual.

The device does not allow performing the sanitation procedure if the programmed maintenance operations have not been carried out within the terms indicated.

the following components are subject to programmed maintenance:

- *active carbon filter*
- *dust filter*
- *ozone sensor*
- *ozone generator*
- *radio control battery*
- *cigar lighter cable fuse*

The maintenance request warning is indicated by:

- *the LEDs flashing*
- *a message via app/software*

Some programmed maintenance operations must be carried out by authorised personnel.

Replacement	Frequency	Maintenance Request Warning	Carried out by
Active carbon filter Dust filter	every 500 sanitation procedures	<ul style="list-style-type: none"> • <i>quick flashing of the green LED when less than 50 sanitation procedures are missing until replacing the filter</i> • <i>a message via app/software</i> 	operator
Radio control battery	when low	<ul style="list-style-type: none"> • <i>the orange LED flashes instead of the green LED in all the notifications</i> 	operator
Cigar lighter cable fuse	if broken	--	operator
Ozone sensor	every 3 years	<ul style="list-style-type: none"> • <i>quick flashing of the green LED and red LED when less than 1 month is missing until replacing the sensor</i> • <i>a message via app/software</i> 	Technical Assistance/ Distributor
Ozone generator	every 20000 hours of use	<ul style="list-style-type: none"> • <i>quick flashing of the green LED and red LED when less than 100 hours are missing until replacing the generator</i> • <i>a message via app/software</i> 	Technical Assistance/ Distributor

21.1 Filter Replacement

The filters must be replaced all together.

In the procedure that follows, the filters will be identified as follows:

- **[A]**: active carbon filter (grey-black, honeycomb structure)
- **[B]**: dust filter (white, pleated structure)

The maintenance request warning is indicated by:

- quick flashing of the green LED when less than 50 sanitation procedures are missing until replacing the filter
- a message via app/software

WARNING



Carrying out the maintenance operations without disconnecting SANITIZER SNT-O3 from the power supply exposes to the risk of injuries.

Disconnect the power supply before carrying out any of the operations described below.

CAUTION



When removing the filters the fans and their support unit remain partially exposed.

- Do not touch the fans or their metal plates.
- Do not insert any object inside SANITIZER SNT-O3 through the fans.

NOTICE



The ozone sensor is fastened to the front cover and connected to the electronics inside SANITIZER SNT-O3 through a cable.

When removing the front cover be careful:

- not to damage the cable;
- not to pull the cable;
- not to disconnect the connector that connects the cable to the sensor;
- not to damage the sensor;
- not to remove the sensor from the front cover.

INFORMATION

SANITIZER SNT-O3 prevents starting the sanitation procedure if this programmed maintenance operation has not been carried out.

Proceed as follows:

1. Stand in front of the filters.

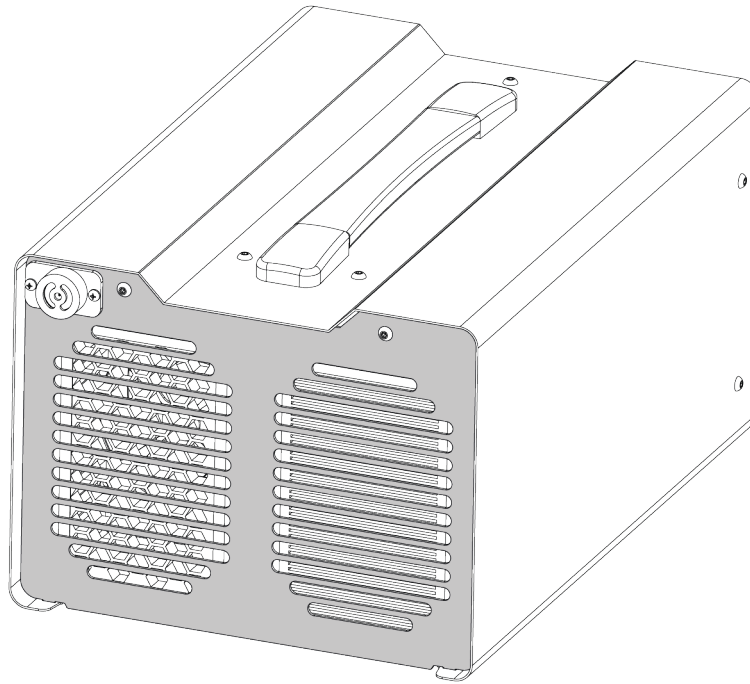

2. Remove the two screws that secure the front cover.

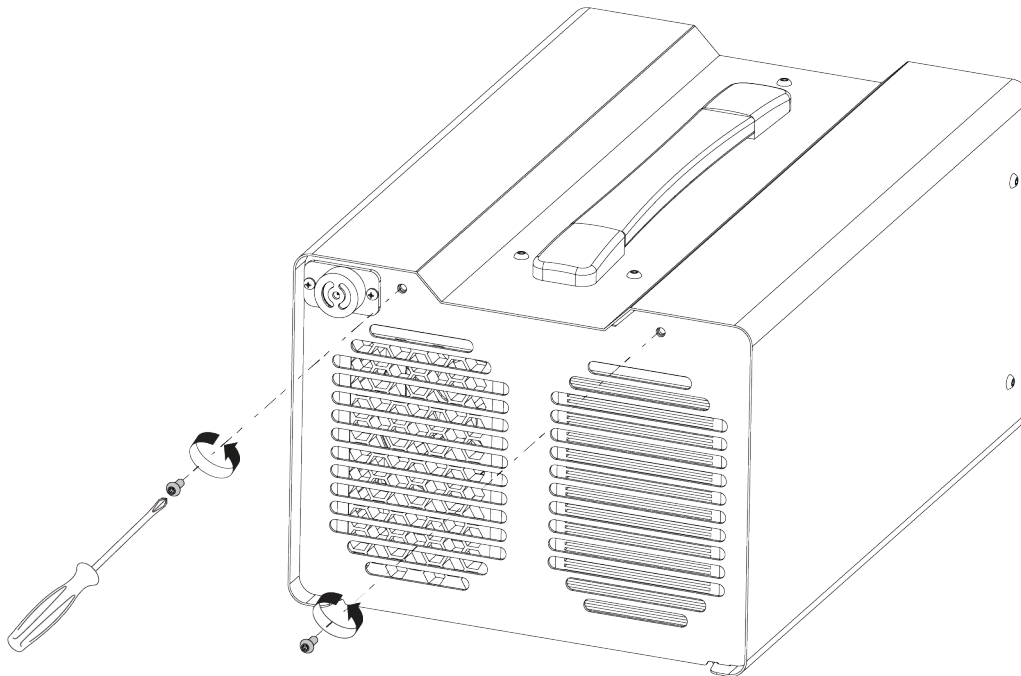

3. Lower the front cover.

NOTICE



The base of the front cover is not fastened with a hinge and only drops to a certain tilt angle.

Do not force the front cover beyond its maximum angle.

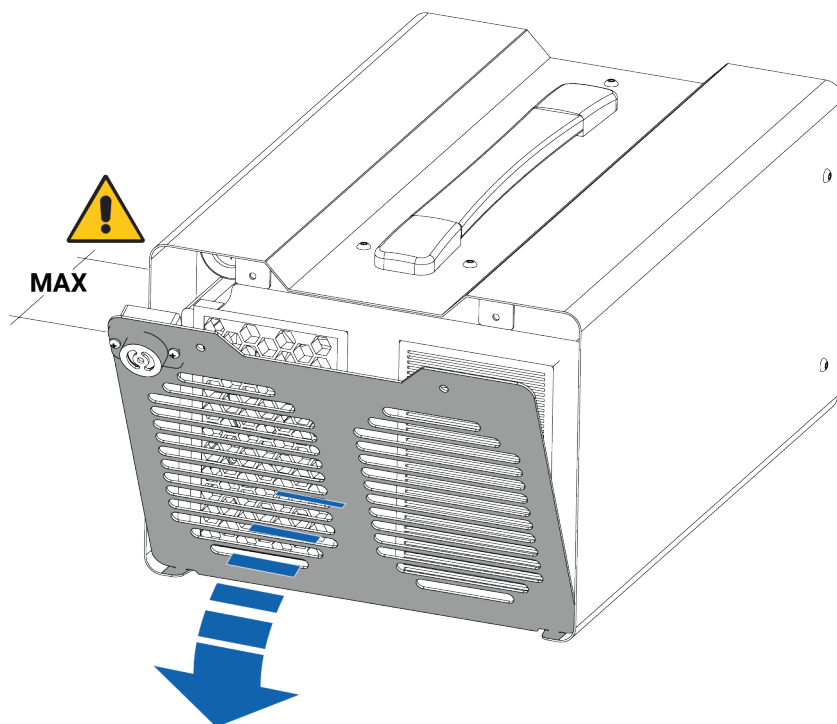

4. Pull out the front cover.

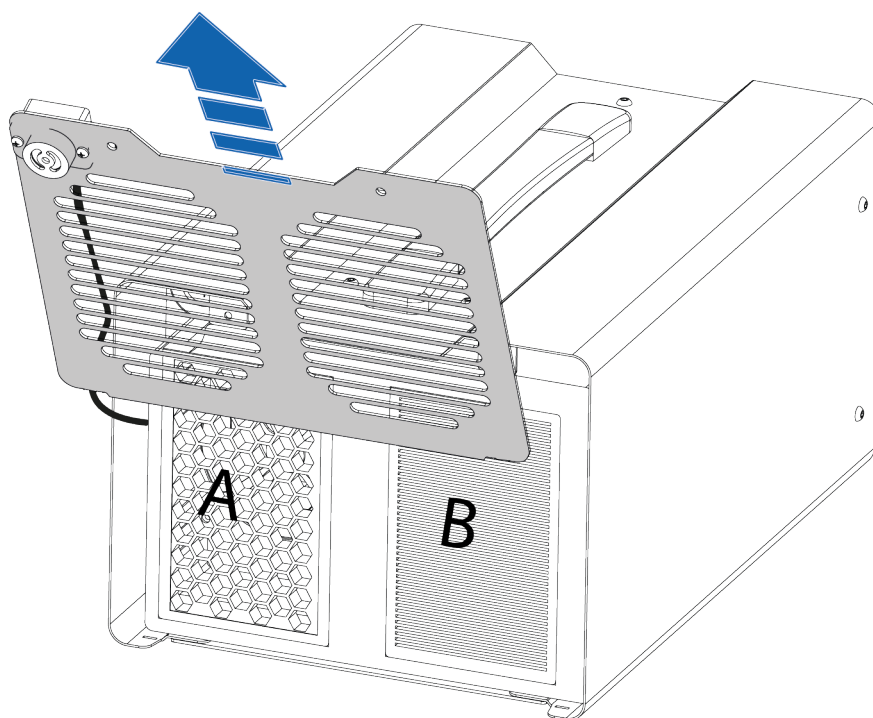

5. Position the front cover near SANITIZER SNT-O3 so that it cannot fall.

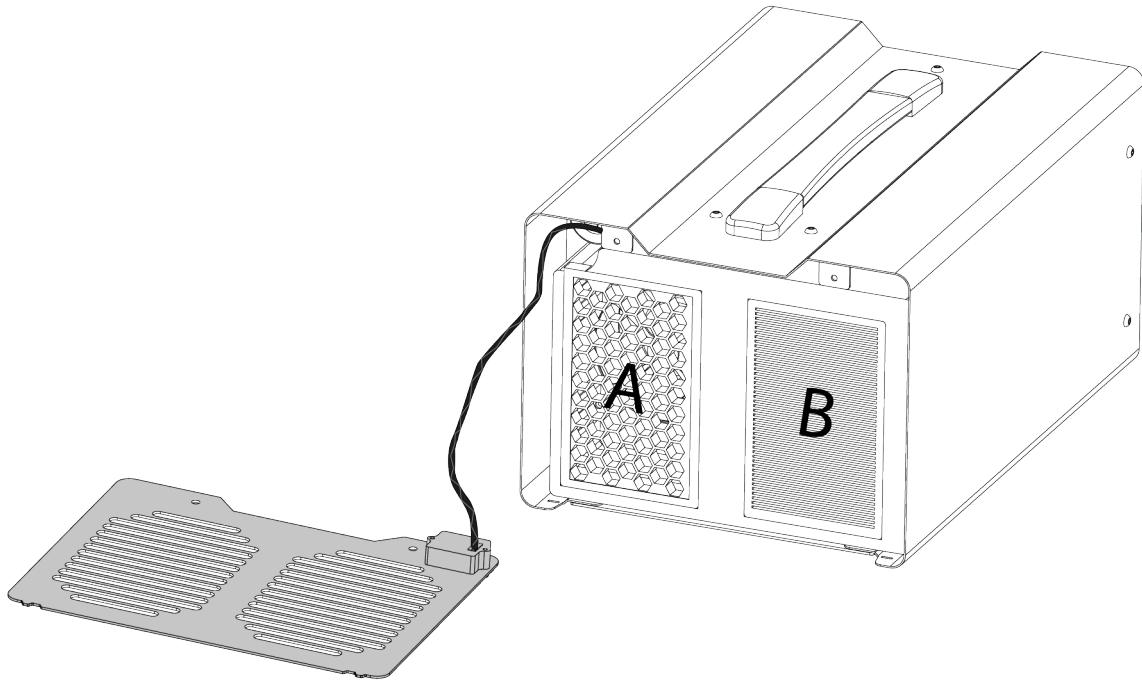

6. Remove the filter [A] being careful not to damage its housing.

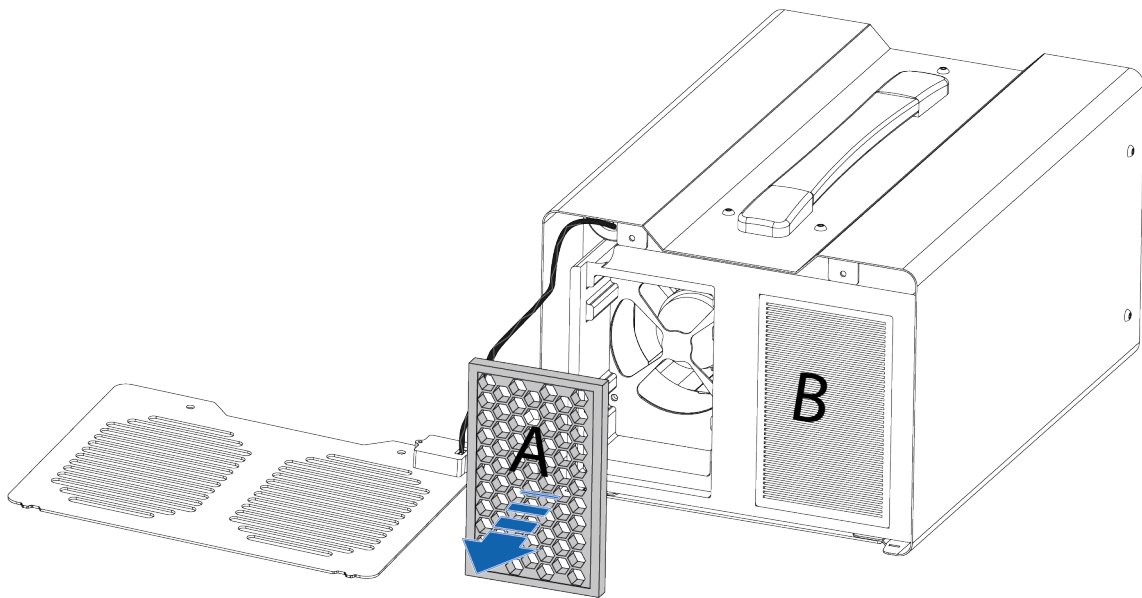

7. Install the new filter making sure it is properly inserted in its housing.

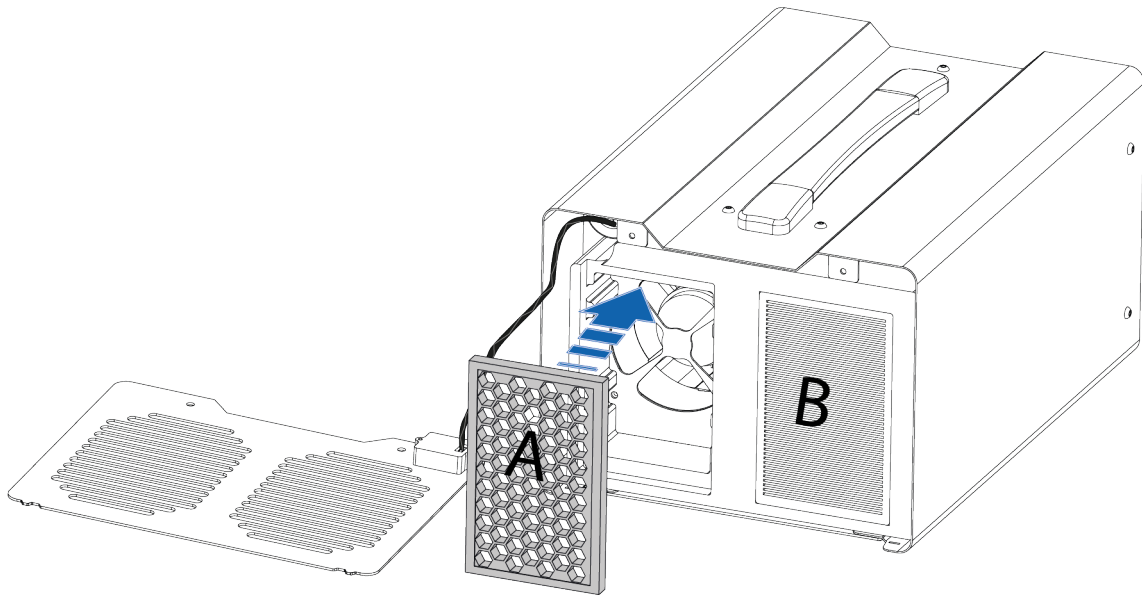

8. Remove the filter [B] being careful not to damage its housing.

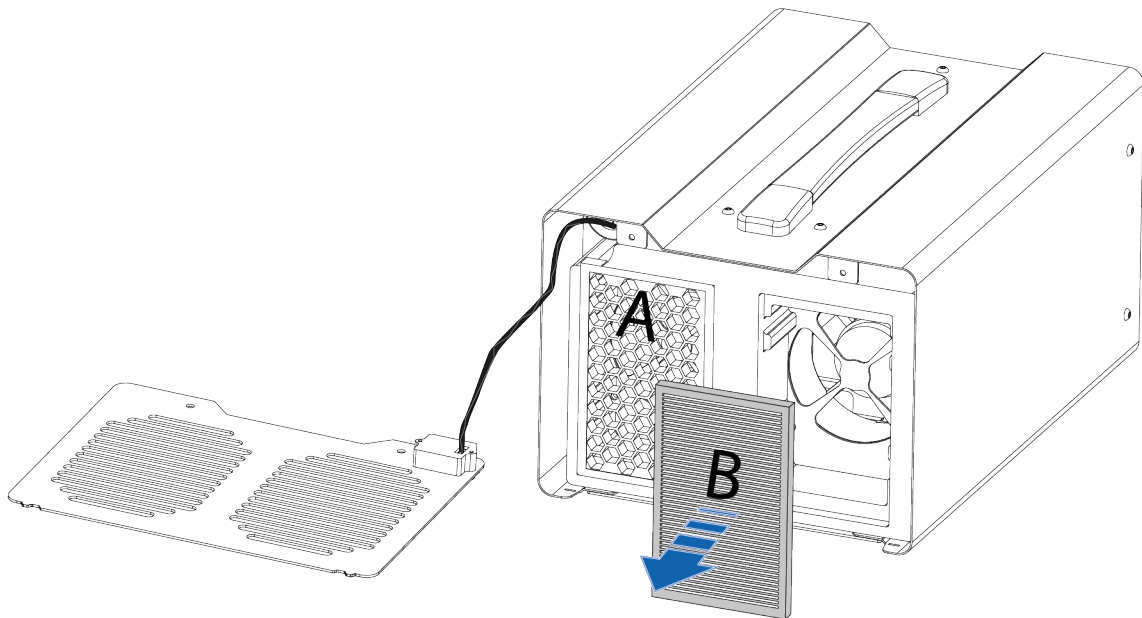

9. Install the new filter making sure it is properly inserted in its housing.

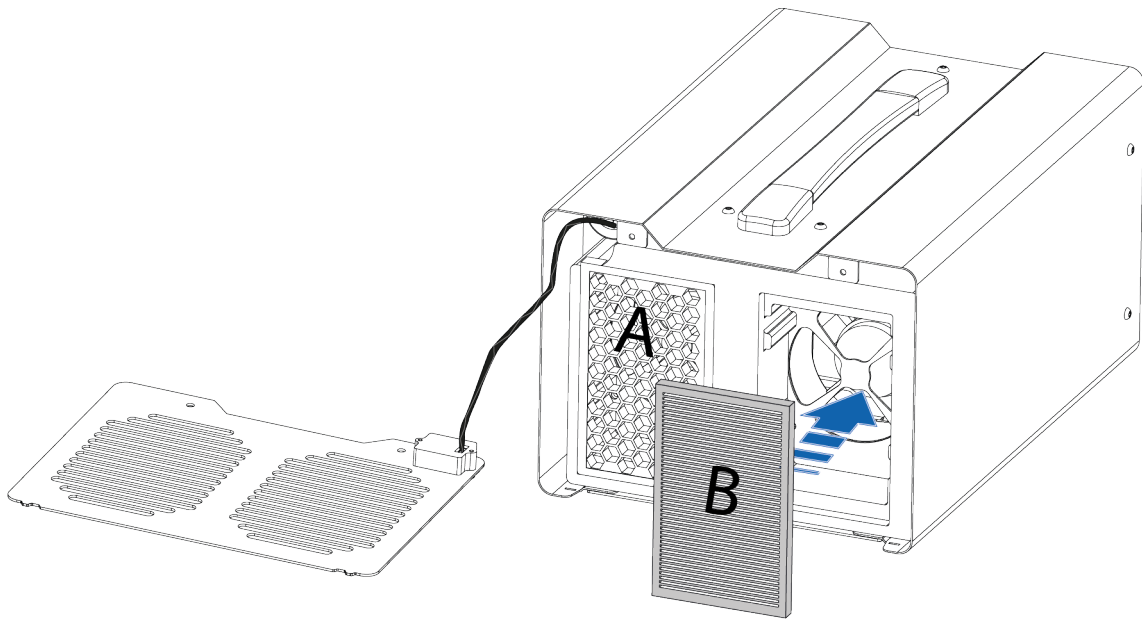

10. Reinstall the front cover.

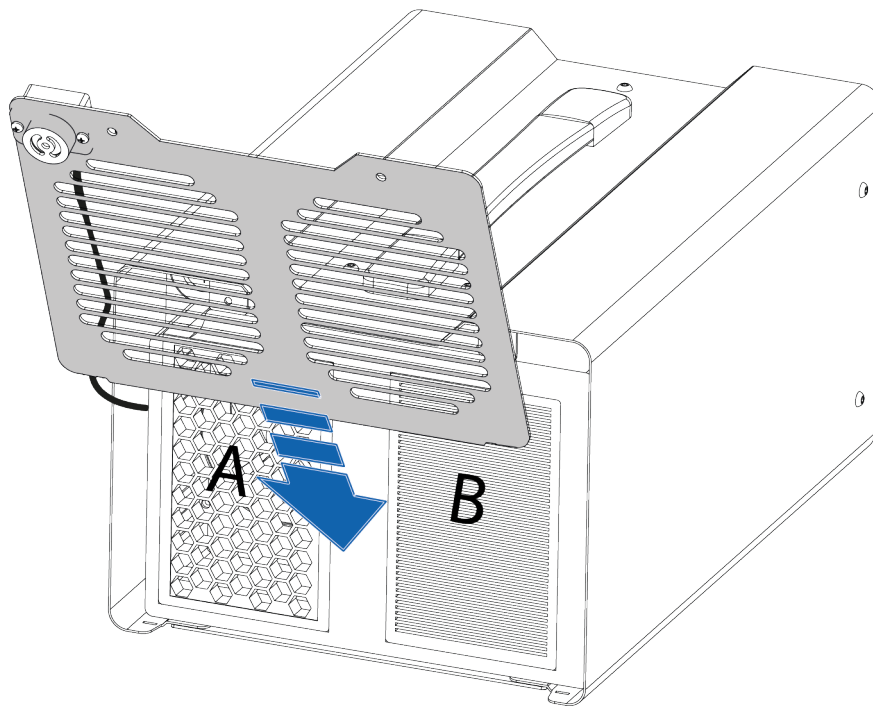

11. Place the sensor's wire inside the specific cavity.

NOTICE

When reinserting the wire, be careful to place it so that it is not pinched when closing the front cover.

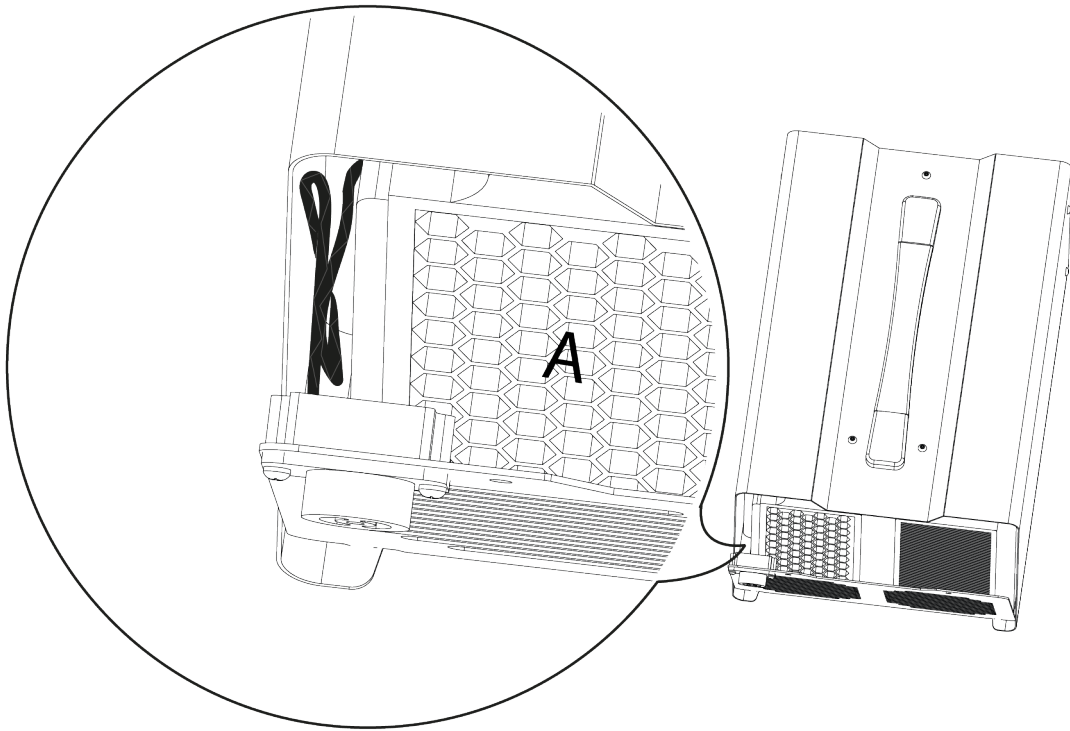

12. Lift the front cover again.

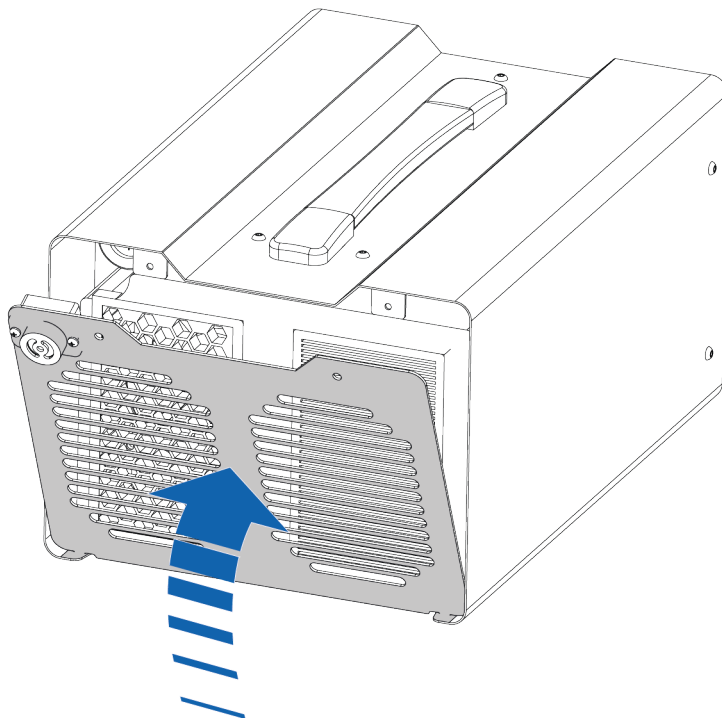

NOTICE

The filters and related housings have different thicknesses and depths.

If the filters are accidentally swapped, it will be impossible to reposition the front cover properly.

- Do not force the front cover closed.
- Position the filters in their correct housing.

13. Secure the front cover with the two screws removed previously.

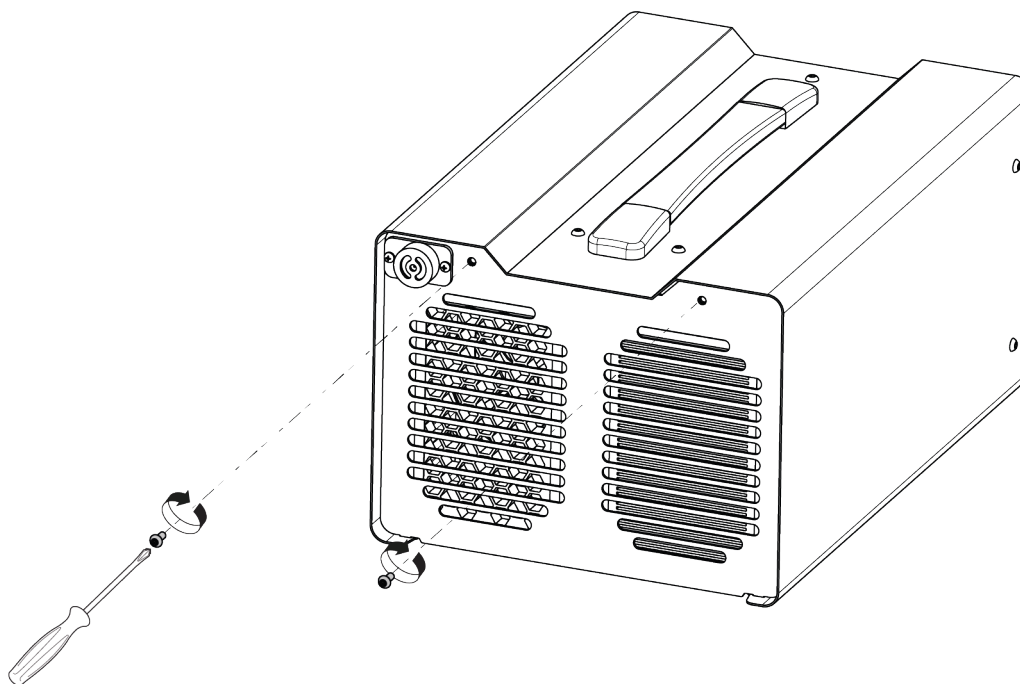

14. Confirm that the filters have been replaced in one of the following ways:

- *holding the button on the radio control for 15 seconds;*
- *pressing the specific icon in the app or software.*

The green LED and the red LD remain on for 10 seconds.

Once 10 seconds have elapsed, the green LED turns off and the red LED stays on.

21.2 Ozone Sensor Replacement

Replacing the ozone sensor is an assistance type operation and must be carried out by personnel authorised by TEXA S.p.A.

INFORMATION

SANITIZER SNT-O3 prevents starting the sanitation procedure if this programmed maintenance operation has not been carried out.

The maintenance request warning is indicated by:

- *quick flashing of the green LED and red LED when less than 1 month is missing until replacing the sensor*
- *a message via app/software*

Contact Technical Assistance or your Distributor.

21.3 Ozone Generator Replacement

Replacing the ozone generator is an assistance type operation and must be carried out by personnel authorised by TEXA S.p.A.

INFORMATION

SANITIZER SNT-O3 prevents starting the sanitation procedure if this programmed maintenance operation has not been carried out.

The maintenance request warning is indicated by:

- *quick flashing of the green LED and red LED when less than 100 hours are missing until replacing the generator*
- *a message via app/software*

Contact Technical Assistance or your Distributor.

21.4 Radio Control Battery Replacement

The primary cell model 2450 in the radio control must be replaced as soon as it gives signs that it is not sufficiently charged.

The maintenance request warning is indicated by:

- *the orange LED flashes instead of the green LED in all the notifications*

Proceed as follows:

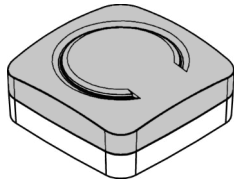

1. Position the device with the button facing upwards.

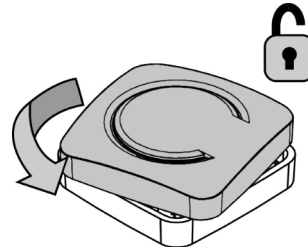

2. Unlock the upper case by delicately turning it counter clockwise.

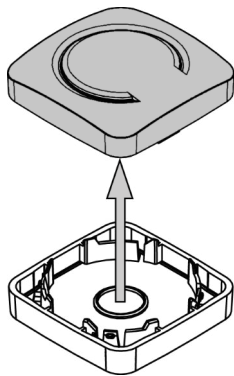

3. Lift the upper case.

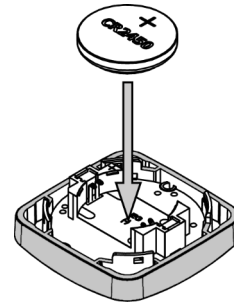

4. Flip over the upper case and insert the battery into its slot with the positive pole facing upwards.

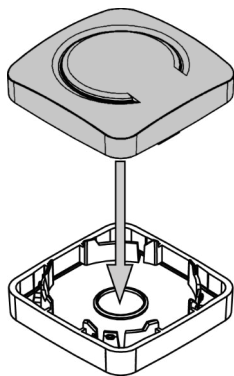

5. Reposition the upper case onto the lower case.

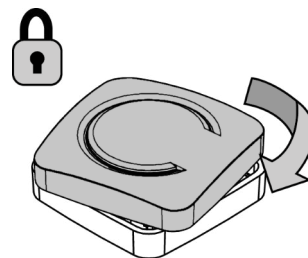

6. Lock the upper case by delicately turning it clockwise.

The radio control sends the self-test warning.

For further information see the RADIO CONTROL: COMMANDS AND NOTIFICATIONS chapter.

21.5 Cigar Lighter Cable Fuse Replacement

If blown, the cartridge fuse [F] must be replaced with one with the same technical features:

- \varnothing 6,3x32 mm
- 6,3 A 250 V

An indication that it is blown can be the fact that the green LEDs does not turn on when the cable is connected to a powered cigar lighter socket (12 V).

WARNING



Disconnect the cable from both the cigar lighter socket and from SANITIZER SNT-O3 before performing any of the operations described below:

Proceed as follows:

1. Unscrew the threaded knurled cap.
2. Remove the blown fuse.

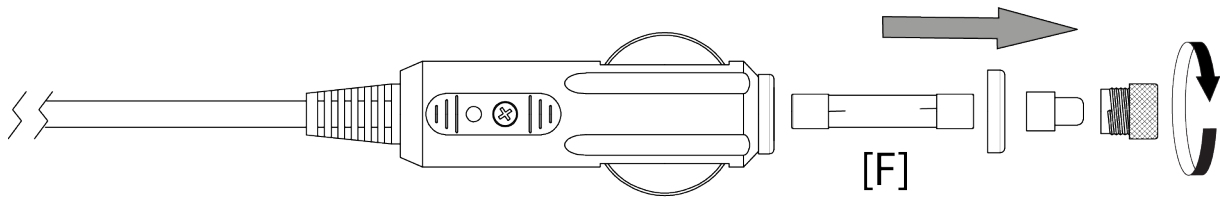

3. Replace the fuse with one that has the same technical features.
4. Screw the threaded knurled cap back on.

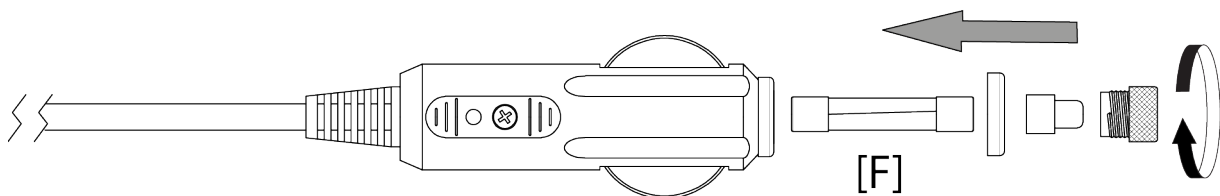

22 TROUBLESHOOTING

For any technical problem contact your retailer/distributor.

Below you will find a list of simple instructions that the customer can carry out without having to ask for technical assistance.

PROBLEM	POSSIBLE CAUSE	POSSIBLE SOLUTION
SANITIZER SNT-O3 does not turn on.	The cigar lighter is not connected correctly.	Connect the cable properly.
	The cigar lighter's fuse is blown.	Replace the fuse. *
	The cigar lighter socket is not powered when the vehicle is off.	Turn on the vehicle (engine running).
	The charger is not connected properly.	Connect the charger correctly.
	The charger is faulty.	Contact Technical Assistance.
No light warning when pressing the button on the radio control.	The battery is low.	Replace the battery. *
Pressing the button on the radio control, the pairing with SANITIZER SNT-O3 is not performed/the sanitation does not start/stops.	SANITIZER SNT-O3 is already communicating with another display unit.	Interrupt the communication with the display unit currently connected (e.g. close the app).
The sanitation is not starting, even though the command is coming from the radio control or another display unit.	A programmed maintenance operation was not carried out.	Perform the programmed maintenance operation. *
	The execution of a programmed maintenance operation has not been confirmed.	Confirm the execution of the programmed maintenance. *
Impossible to close the front cover on SANITIZER SNT-O3 after replacing the filters.	The filters have been swapped.	Position the filters correctly. *

<p>Impossible to configure the communication with SANITIZER SNT-O3.</p> <p>SANITIZER SNT-O3 is not communicating with the display unit.</p>	<p>SANITIZER SNT-O3 is already communicating with another display unit.</p>	<p>Interrupt the communication with the display unit currently connected.</p> <p>E.g. close the app (if there is a sanitation procedure in progress it will be interrupted).</p>
	<p>The communication configuration procedure has not been carried out.</p>	<p>Perform the communication configuration procedure. **</p>
	<p>SANITIZER SNT-O3 and the display unit are outside the range of action of the Bluetooth signal.</p>	<p>Position SANITIZER SNT-O3 close to the display unit.</p>
	<p>SANITIZER SNT-O3 was placed near shielding materials.</p>	<p>If possible, position SANITIZER SNT-O3 far from shielding materials keeping it inside the environment that must be sanitised.</p>
	<p>Other wireless communications are disturbing the signal.</p>	<p>Move away from possible sources of interference.</p>
		<p>If possible, switch off the devices causing the interference.</p>
		<p>Wait and try to communicate again.</p>
<p>SANITIZER SNT-O3 is already communicating with another display unit.</p>	<p>Interrupt the communication with the display unit currently connected (e.g. close the app).</p>	

(*) For further information see the *MAINTENANCE* chapter.

(**) For further information see the *COMMUNICATION* chapter.

23 LEGAL NOTICES

TEXA S.p.A.

Via 1 Maggio, 9 - 31050 Monastier di Treviso - ITALY

Tax Code - Company Register of Treviso ID No. - VAT No.: 02413550266

Single-shareholder company subject to the direction and coordination activities of Opera Holding S.r.l.

Paid-up share capital 1,000,000 € - R.E.A. (Economic Administrative Index) No. 208102

Legal Representative Bruno Vianello

Phone +39 0422.791.311

Fax +39 0422.791.300

www.texa.com

For information regarding the legal notices, please refer to the **International Warranty Booklet** provided with the product.