

# MOBILE COLUMN LIFT

## WIRED

The mobile column lifts by Blitz are a perfect synthesis of flexibility and stability. Free areas - make optimum use, both in the workshop as well as outdoors.

- + Double load protection ensures safety
- + Intuitive operation
- + Quick change of position by forklift possible

Subsequent extension from 2 to 3, 4, 6 or 8 lifting units is possible.

Synchronization of all lifting units even with unequal load distribution. The deviation value is only 20 mm.

Communication and power supply is provided by a 15 m connection cable.

Double load protection by means of a shut-off valve and mechanical safety catch.

The lifting cylinder is located in the lifting carriage and protected against external influences. The motor and the hydraulic unit are also completely covered.

All functions are available on each lift column.

Low-friction rollers literally make setting up the workplace child's play.

Emergency stop button on each column.

Intuitive operation.

Large-scale production in our ISO-certified production facilities enables a constantly high vertical range of manufacture.

A 10 m cable with plug serves as mains supply line to the master column.



## HIGHLIGHTS IN DETAIL

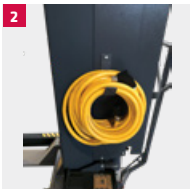

- 1** The VARIO fork ensures the accommodation of tire sizes from 570 to 1300 mm as well as Super-Single without additional adapters.
- 2** Communication and electrical supply is provided by stable 15 m electric cables.
- 3** Movable drawbar with self-deflecting steering chassis, double roller and integrated parking brake prevent the lifting unit from rolling away unintentionally.
- 4** Forklift adapters allow quick and easy transport of the mobile column lifts in the workshop.
- 5** The FS profile offers optimal protection of the wheel hub.
- 6** Intuitive operation via well-arranged operating elements.
- 7** All mobile lift columns are equipped with sockets and can be easily connected with cables.
- 8** A switch box with integrated main switch and 10 m power cable with plug is attached to the master column.

## HydroLift S3 6.2 / 7.5

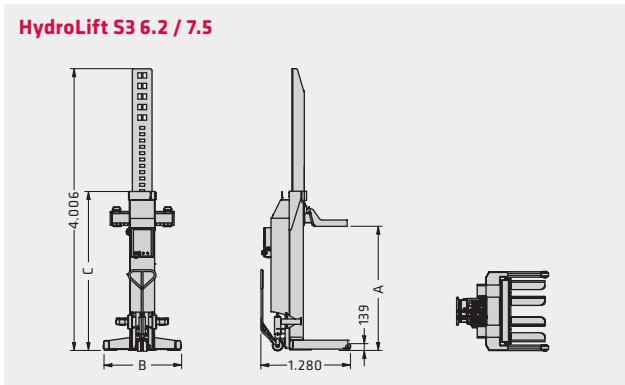

Model	HydroLift S3									
	2-6.2	3-6.2	4-6.2	6-6.2	8-6.2	2-7.5	3-7.5	4-7.5	6-7.5	8-7.5
Capacity	2 x 6.2 t	3 x 6.2 t	4 x 6.2 t	6 x 6.2 t	8 x 6.2 t	2 x 7.5 t	3 x 7.5 t	4 x 7.5 t	6 x 7.5 t	8 x 7.5 t
Tyre size	570-1300 mm									
A Stroke	1.753 mm	1.753 mm	1.753 mm	1.753 mm	1.753 mm	1.753 mm	1.753 mm	1.753 mm	1.753 mm	1.753 mm
Lifting time	65 s									
Lowering time	54 s									
Lift cycles fully loaded	400 V/50 Hz/16 A									
Driving power	3 kW	3 kW	3 kW	3 kW	3 kW	3 kW	3 kW	3 kW	3 kW	3 kW
B Width	1.107 mm	1.107 mm	1.107 mm	1.107 mm	1.107 mm	1.107 mm	1.107 mm	1.107 mm	1.107 mm	1.107 mm
C Height	2.260 mm	2.260 mm	2.260 mm	2.260 mm	2.260 mm	2.260 mm	2.260 mm	2.260 mm	2.260 mm	2.260 mm
Weight per column	620 kg	620 kg	620 kg	620 kg	620 kg	620 kg	620 kg	620 kg	620 kg	620 kg
Article number	128544	128543	128545	128546	128547	124709	128541	124710	124711	124712

# TECHNICAL SPECIFICATIONS

## ACCESSORIES

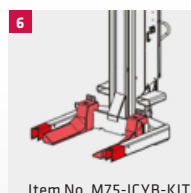
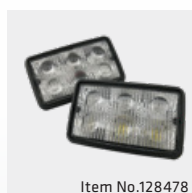
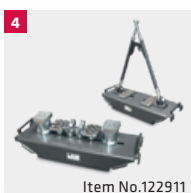
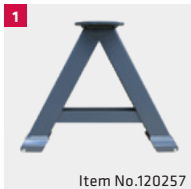

- 1 HydroLift kingpin holder. Load capacity 12.4 t
- 2 HydroLift. Load capacity 12.4 t
- 3 Jet water protective cover for HydroLift
- 4 Agricultural vehicle lifting arms for HydroLift
- 5 LED lighting kit (2 pieces), also for retrofitting
- 6 Wheel fork extension 150 mm. Ideal for motor homes

Technical changes reserved. Data are considered advertisement.  
Mobile-Column-Lift-HydroLift S3 6.2-7.5 wired-BR-129106-en-2020-09