



Operating instructions

DUPLEX S2

In-ground truck lift



Type

Serial number

Date



EC Declaration of Conformity

according to EU machine directive 2006/42/EG (Annex II A)

Name and address of manufacturer: BlitzRotary GmbH
Hüfinger Str.55
78199 Bräunlingen,
Germany

This declaration only relates to the machine in condition as supplied; components added and/or subsequent modifications made by the end user are disregarded. This declaration becomes invalid if the product is changed or modified without permission.

We declare that the undermentioned machine,

Product name: In-ground truck lift Duplex S2,
with 1, 2, 3, 4, 5, or 6 lifting cylinders

Serial / type name: T1-15-1900, T2-15-1900, T3-15-1900
T4-15-1900, T5-15-1900, T6-15-1900

Machine/serial number:

Year of manufacture: 20...

complies with all relevant provisions or the machine directive 2006/42/EG.

In addition the machine complies with the provisions of the directives 2004/108/EG electro-magnetic compatibility (safety objectives were complied with according to Annex I, no. 1.5.1 machine directive 2006/42/EG).

Applied harmonized standards:

EN 1493:1998+A1:2008	Vehicle lifts
EN ISO 12100-1 : 2003	Safety of machinery – Basic concepts
EN ISO 12100-2 : 2003	Safety of machinery – Basic concepts
EN 60204-1:2006+7/2007	Electrical equipment of machines
EN 349:1993+A1:2008	Safety of machinery – Minimum gaps
EN ISO 13850:2008	Safety of machinery – Emergency stop
EN ISO 14121-1:2007	Safety of machinery – Risk assessment
EN ISO 13849-1:2008	Safety-related parts of control systems T1
EN ISO 13849-2:2008	Safety-related parts of control systems T2

Other applied technical standards and specifications:

BGG 945	Inspections of lifts
BGR 500	Operation of work equipment
BGV A3	Accident prevention regulation electric equipment and production equipment

EU prototype examination no.: D 06 AA3887101

EU notified body No. 0124 , DEKRA certification

Representative for the compilation of relevant technical documentation

BlitzRotary GmbH, Hüfinger Str. 55, 78199 Bräunlingen

Place, date

Bräunlingen, 20.03.2013

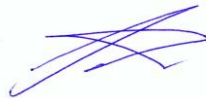

Frank Scherer / Managing Director



Contents

1. Foreword	1		
1.1 About these operating instructions	1		
1.2 Important information for equipment operators	1		
1.3 Expert staff for safety-relevant operations 1			
1.4 In-house accident, health and environmental information	2		
1.5 Warnings and symbols	2		
2. Intended use	3		
2.1 Misuse	3		
3. The lift	3		
3.1 Mode of operation	3		
3.2 Technical data	3		
3.3 Equipment overview	4		
3. The lift	4		
3.1 Permissible load distribution	5		
3.2 Workplace, danger zones	6		
3.3 Safety mechanisms	7		
3.4 Control cabinet	9		
3.5 Control panel	10		
4. Safety precautions	11		
4.1 Standard operation	11		
4.2 Operational safety, malfunctions	11		
4.3 Pick-up points	11		
4.4 Lifting / lowering	11		
4.5 Operation without controls "FOR"	11		
4.6 Installation, maintenance, repair	11		
5. Operation	12		
5.1 Emergency stop	12		
5.2 Switch on equipment	12		
5.3 Lift allocation (optional)	12		
5.4 Detect vehicle data	12		
5.5 Drive vehicle on lift	13		
5.6 Detect pick-up points on vehicle	13		
5.7 Select pick-up equipment	13		
5.8 Attach lifting cylinders to vehicle	13		
5.9 Activate synchronous operation	13		
5.10 Lifting / lowering	13		
5.11 Drive vehicle off the lift	14		
5.12 Switch off equipment	14		
5.13 Operation without controls "FOR"	14		
5.14 Store distance between axles – option "AAV" –	15		
6. Malfunctions	16		
6.1 Emergency lowering	17		
7. Malfunction reports	18		
7.1 Malfunction indicator lamps	18		
8. Maintenance	19		
8.1 Qualification maintenance staff	19		
8.2 Safety precautions	19		
8.3 Maintenance schedule	19		
8.4 Cleaning	20		
8.5 Check hydraulic oil level	20		
8.6 Permitted hydraulic oils	20		
8.7 Check hydraulic components for leakages 21			
8.8 Tighten mounting screws of cross members and shafts	21		
8.9 Bleed lifting cylinder	22		
8.10 Check indicator lamps	22		
8.11 Carry out function test	22		
8.12 Check safety cylinders	22		
8.13 Calibrate sensor setting	23		
8.14 Change hydraulic oil	23		
9. Repair	24		
9.1 Change gaskets	24		
10. Safety checks	25		
11. Transport, storage	25		
11.1 Storage	25		
11.2 Transport	25		
12. Setting up	27		
12.1 Set-up regulations	27		
12.2 Electric connection	27		
12.3 Set-up remarks	27		
13. Start-up	28		

Contents

14. Disassembly.....	28
15. Disposal.....	28
15.1 Packaging materials	28
15.2 Environmental disposal regulations	28
15.3 Metal / electronic scrap	28

ANNEX	29
--------------------	-----------

Inspection book with

- Master data sheet DUPLEX-S2 lift
- Form "Set-up protocol"

- Form "Handover certificate"
- Form "Initial safety check before start-up"
- Form "Annual safety check"
- Form "Special safety check"
- Maintenance report

Diagrams, spare part lists, additional instructions

- Electric diagram → see control cabinet
- Hydraulics diagram
- Spare part lists

1. Foreword

1.1 About these operating instructions

The state-of-the-art in-ground lift complies with applicable occupational health and safety regulations. However, with improper use or misuse danger to life of the user or third parties can arise and property can be damaged.

It is therefore very important that the persons responsible are familiar with these operating instructions.

Read the instructions carefully to avoid operating errors, risks and damage. Use the in-ground lift only as intended.

Please observe the following:

- The operating instructions must always be available close to the lift.
- **Familiarize yourself in detail with chapter 4, safety precautions and with the operating instructions on the lift.**
- We are not responsible for damages and downtimes arising from non-observance of these operating instructions.
- Lift installation and initial start-up may only be carried out by authorized specialized installers (factory-trained technicians) and electricians.
- Contact the authorized customer service in case of malfunctions.
- Illustrations may differ from the supplied lift. However, functions or operating steps are the same.

Legal notice:

Printing errors, mistakes and technical modifications reserved.

Trademarks and brands referred to in this document refer to their owners or their products.

This is a translation, the German original wording has priority

1.2 Important information for equipment operators

The operating instructions contain important information for the safe operation and maintenance of the operational safety of the lift.

- Return the form "Installation checklist" to the manufacturer as verification of installation.

- The "Inspection book" contains forms for the initial, regular and special safety inspections. Use the forms to record the inspections and leave the completed forms in the book.
- Enter design modifications in the "Equipment master data sheet".

The equipment operator must ensure that safe operation is guaranteed at all times and that the following specifications are observed and regularly checked.

- The operating staff must be qualified, trained and experienced.
- The operating staff must know the occupational health and safety regulations and must be trained in operating the lift.
- The operating staff must have read, understood and signed the safety precautions.
- A supervisor must be appointed if several persons work on the in-ground lift.
- The lift must only be operated in safe condition.
- Repair and maintenance work is to be carried out at regular defined intervals.
- Safety checks according to chapter 10 must be carried out regularly at least once per year.
- The inspection book is to be kept according to requirements.
- These operating instructions and related instructions in the Annex must be kept at the lift. This also applies to after sale or re-installation at a different location.
- Unauthorized lift modifications are not permitted. Unauthorized modifications lead to the expiry of the operating permit; the declaration of conformity becomes invalid.

1.3 Expert staff for safety-relevant operations

Lift inspection is required after initial start-up and at regular intervals at least once per year.

Inspection is also necessary after replacing safety-relevant components during maintenance.

Safety-relevant work and safety inspections on lifts must only be carried out by expert staff. These are generally competent persons or authorized experts.

- **Authorized experts** are persons (freelance specialized engineers, TÜV experts), who are permitted to inspect lifts due to their training and experience. They are familiar with the relevant occupational and health regulations.

Competent persons are persons with sufficient knowledge and experience with lifting equipment. They have attended special training at the lift manufacturer. Competent persons are service technicians of the manufacturer or authorized dealer.

1.4 In-house accident, health and environmental information

These operating instructions contain no information and instructions for rules of conduct in case of accidents and health hazards.

The in-house operational instructions are to be provided by the lift operator.

1.5 Warnings and symbols

Warnings are identified by the following symbols according to their hazard classification.

In situations identified by warnings, be especially aware of safety and danger. Observe the occupational health and safety regulations for your country.



DANGER

Danger to life/risk of injury

Immediate danger for life and personal injuries. Non-observance can lead to death or severe injuries.



WARNING

Danger to life/risk of injury

Possible danger for life and personal injuries. Non-observance can lead to severe or life-threatening injuries.



CAUTION

Risk of injury

Possible dangerous situation. Non-observance can lead to light or moderate injuries.

ATTENTION

Damage to property

Potentially dangerous situation. Non-observance can lead to damage.

Other symbols



INFO symbol

Useful information and tips.

- **Bullet list symbol:**
For lists with important information about the respective topic.
- 1. **Standard operational procedure:**
Carry out the specified steps in sequence.
- ➔ **Standard operational procedure warning**
Carry out the specified steps in sequence.

2. Intended use

The lift is intended to be used to lift and lower commercial vehicles for repair, maintenance and cleaning during normal workshop operation.

The lift is only to be used as intended, in technically sound condition according to technical specifications in chapter 3.2.

The maximum load capacity of one lifting cylinder is 15 000 kg and must not be exceeded. The permissible load distribution in or against drive direction is 2:1.

Standing or working under suspended load is permitted.

2.1 Misuse

Improper behavior can cause danger to life and health of persons working in the vicinity of the lift.

The manufacturer is not responsible for damages caused by use against regulations and misuse.

Prohibited:

- Standing and riding on load and load-bearing equipment.
- Standing or working under the load during lifting and lowering.
- Lifting of vehicles loaded with hazardous goods.
- Lift installation in explosive areas.

3. The lift

3.1 Mode of operation

- The lift is used to lift heavy vehicles for maintenance, cleaning or repair to optimum working height.
- Operation is carried out with a mobile control panel.
- Lifting and lowering the vehicle is carried out in jog mode.
- Electronic controls ensure level lifting of the vehicle.
- The lifting cylinders are movable in vehicle longitudinal direction to adjust for different distances between axles.

3.2 Technical data

Duplex versions with 1...6 lifting cylinders

- Duplex S2-T1-15-1900
- Duplex S2-T2-15-1900
- Duplex S2-T3-15-1900
- Duplex S2-T4-15-1900
- Duplex S2-T5-15-1900
- Duplex S2-T6-15-1900

	Duplex
Stroke [mm]	1900
Capacity per lifting cylinder [kg]	15000
Operating pressure [bar]	100
Set pressure safety valve [bar]	110
Installation depth [mm]	
● Frame	1400
● Trough	1450
Lifting time [s]	85
Lowering time [s]	52
Drive power per lifting cylinder [W]	3000
Piston diameter [mm]	180/150
Oil filling per cylinder [l]	57
Noise level [db (A)]	70
Cross member	
● Height [mm]	70
● Extension [mm]	650-1040
Electrical data	
● Nominal voltage [V]	400 3+N+PE
● Mains frequency [Hz]	50
Optional Flexcover Maximum load per wheel [kg]	3000
Ambient temperature	10...40°C

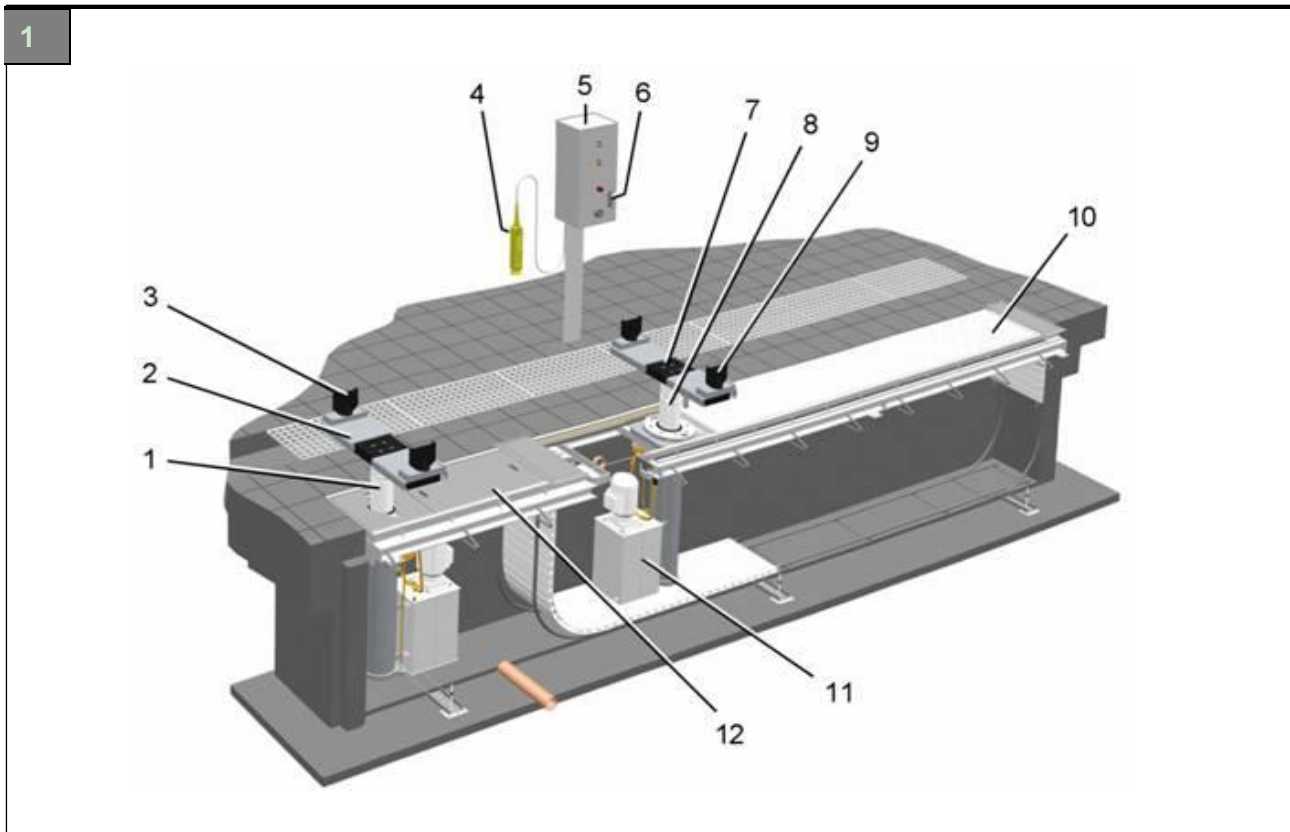

3.3 Equipment overview

Illustration 1: Example of lift with 2 lifting cylinders

- 1 Lifting cylinder, fixed
- 2 Cross member
- 3 Load-bearing equipment
- 4 Control panel, mobile
- 5 Control cabinet with controls
- 6 Type plate
- 7 Cross member
- 8 Lifting cylinder, movable
- 9 Load-bearing equipment
- 10 Cover
- 11 Hydraulic unit
- 12 Maintenance door

3.1 Permissible load distribution

Illustration 2: Vehicle center of gravity

- The overall center of gravity of the vehicle must be centered above the hydraulic cylinder.

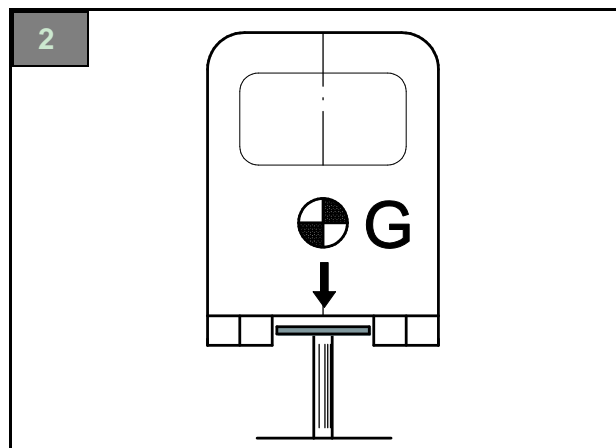

Illustration 3: Nominal load per lifting cylinder

- Maximum 15 t, minimum 0.8 t
- Load distribution in or against driving direction: maximum 2:1
- Minimum distance between lifting cylinders in driving direction 1.5 m

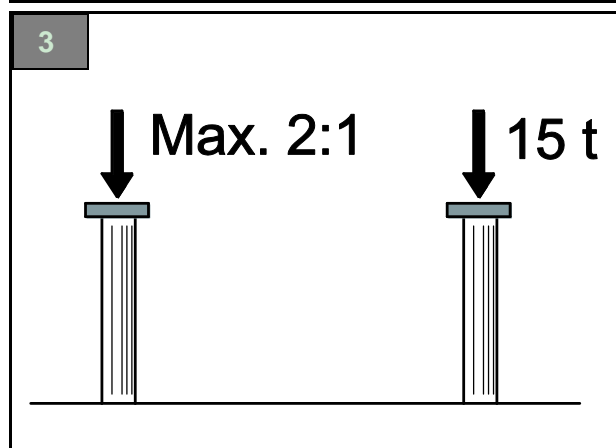

Illustration 4: Flexcover

Permissible traversing load maximum 3 t per wheel

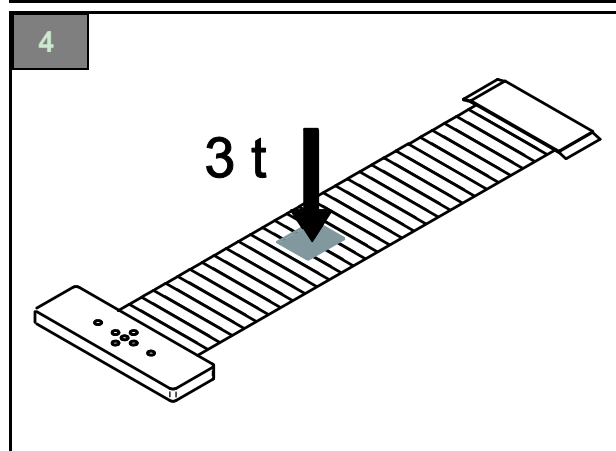
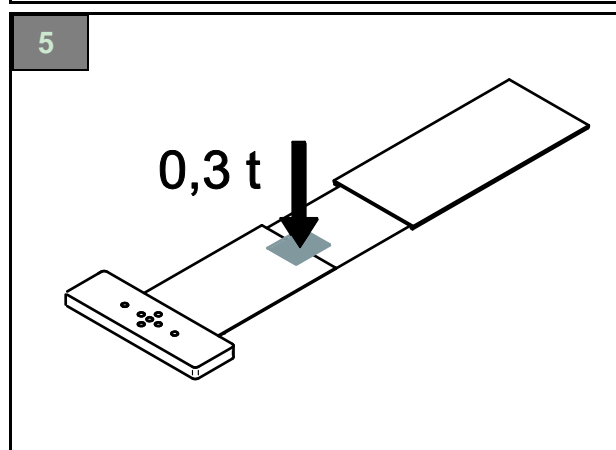
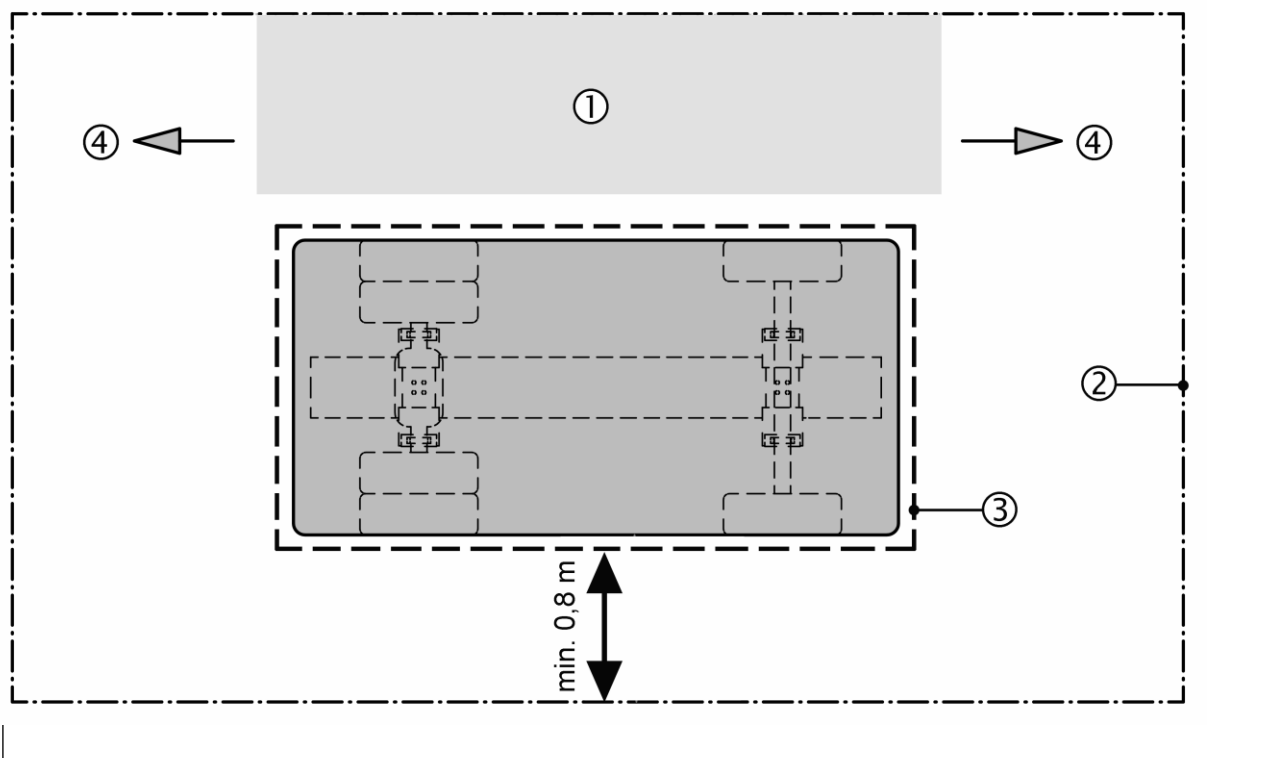

Illustration 5: Metal cover

Permissible traversing load maximum 0.3 t per wheel



6



3.2 Workplace, danger zones

Illustration 6: Work and danger zones

- 1 Operating position
- 2 Working area
- 3 Danger zone
- 4 Escape route

3.3 Safety mechanisms

Illustrations 7 ... 10: Safety mechanisms

Electric

- Emergency stop switch on control panel and control cabinet
- Main switch, lockable
- Dead man's control for lifting and lowering
- Synchronous run control ± 45 mm
- Synchronous run monitoring < 100 mm
- Electronic controls with second CPU for monitoring
- Safety stop during lowering 500 mm above floor level
- Acoustic alarm during lowering

Hydraulic

- Safety cylinder with 2 independent hydraulic circuits
- Overload pressure control valve
- Seat valve in case of drive failure
- Flow control valve for speed limitation during lowering

Mechanical

- Protective housing for leakage detection

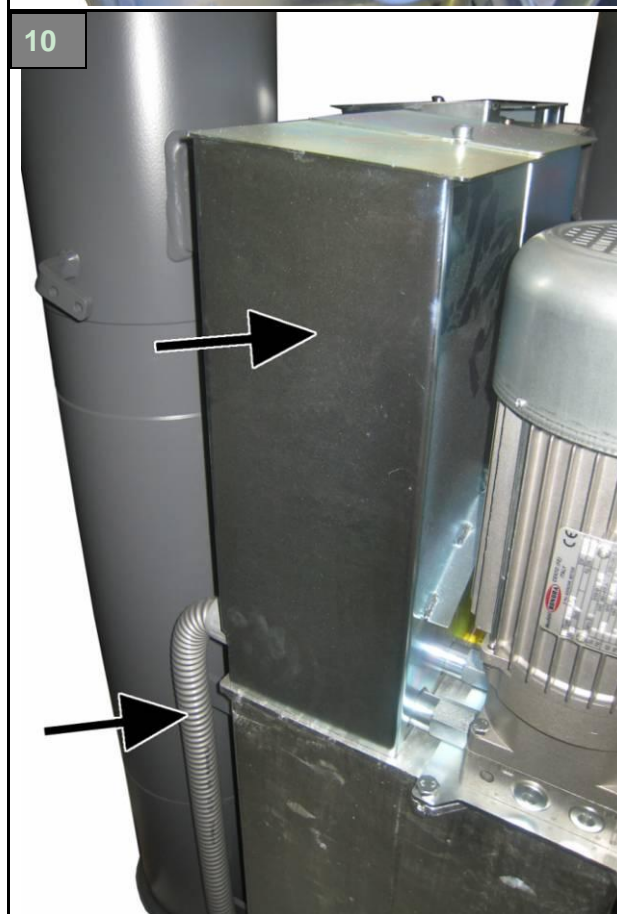
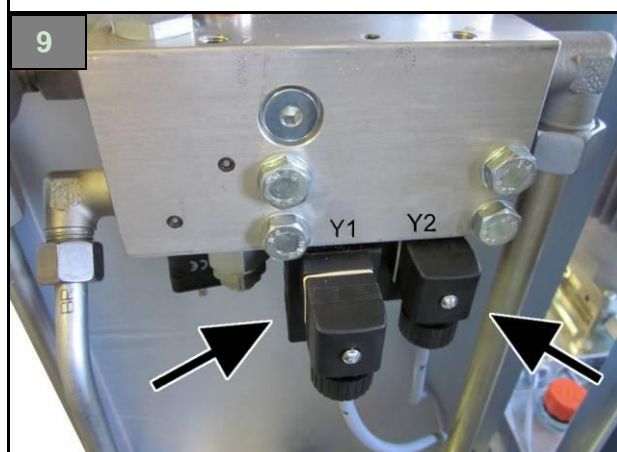
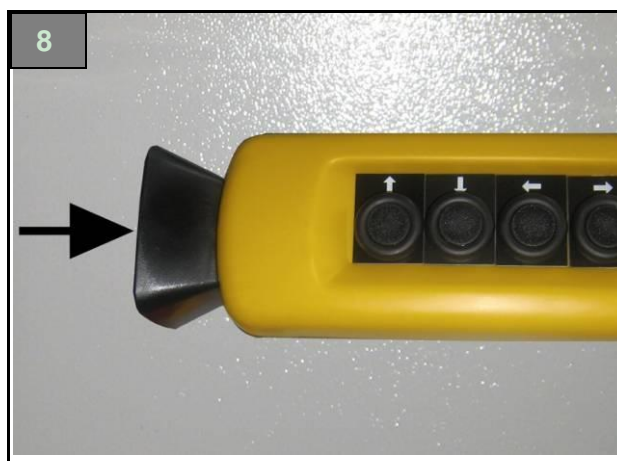

3.4 Control cabinet

Illustration 11: Controls on control cabinet

- 1 Main switch, emergency stop**
 - 2 Controls On**
Turns the main contactor on. The control panels are now activated.
 - 3 Controls Off**
Turns the main contactor off. The control panels are now deactivated.
 - 4 Buzzer**
Acoustic alarm during lowering the lift below 500 mm (foot protection).
 - 5 Lift allocation switch (optional)**
Lifts with 4, 5 or 6 lifting cylinders can be divided into individual workplaces.
 - A control panel is available for each workplace.
 - The individual control panels are activated corresponding to the lift allocation.
 - 6 FOR key switch**
Manual adjustment of the vehicle position.
 - Automatic controls are deactivated.
 - Current lift allocation is canceled.
 - Control panel 1 is activated.
 - Control commands Up ↑ and Down ↓ apply to activated lifting cylinder.
- 7** For safety reasons, a second operator must be called in. This person must permanently activate FOR switch and monitor the operator.
- 7 Fault report indicators L1 ... L4**
15 fault reports are allocated to the 4 indicators, depending on On/Off combination (→ chapter 7).

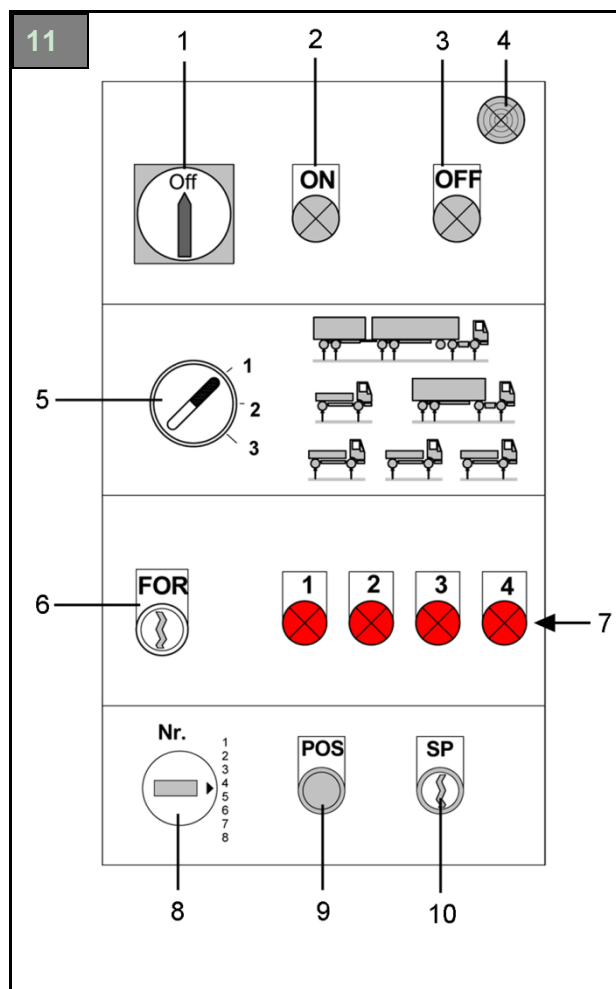

Distance between axles preset "AAV", optional (→ chapter 5.14).

- 8 Rotary switch for 9 memory presets**
The necessary lifting cylinder positions for frequently used vehicles can be stored.
- 9 POS button**
The lifting cylinders move to the selected position.
- 10 SP key switch**
The current lifting cylinder position is programmed for the set memory preset (position number).

3.5 Control panel

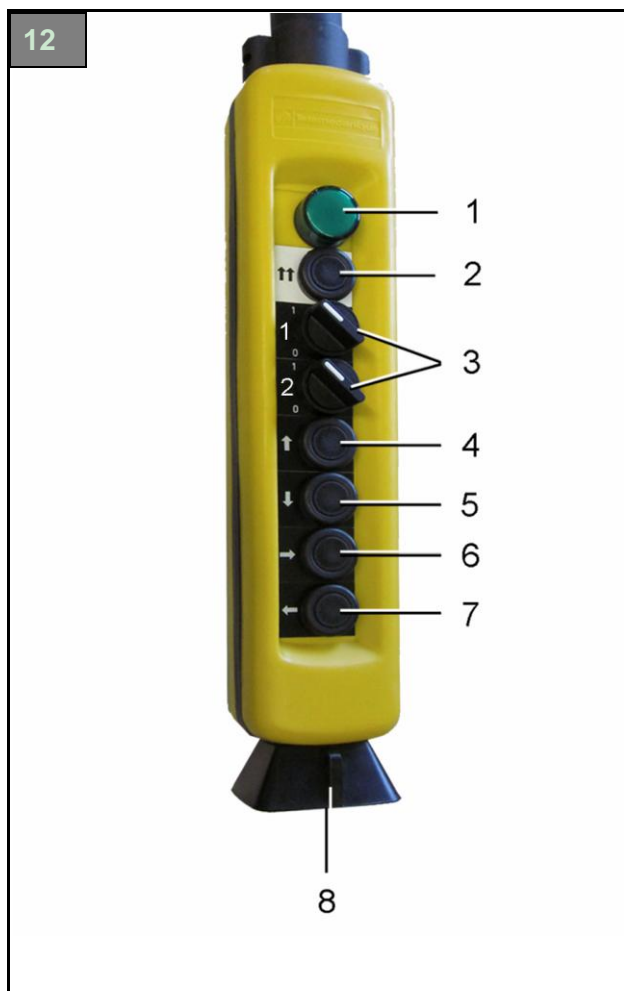

Illustration 12: Control panel

- 1 Mode indicator lamp**
Flashes: Selected lifting cylinder loaded
Lights up: Synchronized operation activated
- 2 Synchronized operation On/Off push button**
- 3 “Activate Lifting cylinder” switch**
- 4 ↑ button**
Lift
- 5 ↓ button**
Lower
- 6 → button**
Drive forward in pit
- 7 ← button**
Drive back in pit
- 8 Emergency stop button**

4. Safety precautions

Observe the following instructions under all circumstances!

4.1 Standard operation

- Only operate the lift after reading and understanding these operating instructions. Follow the short operating manual on the lift.
- The permissible overall load capacity per lifting cylinder is maximum 15,000 kg (see axle load in manufacturer's specifications).
- for the lift may only be operated by persons who are older than 18 years of age, trained for lift operation and who have signed the handover report.
- Only use the lift with a covered pit.
- Vehicles with low ground clearance or with optional extras must be inspected upfront. Only lift these vehicles if no damage will occur.
- Work on the lift only with the main switch turned off and locked.
- Prohibited:
 - Passenger transport with the lift.
 - Climbing on lift or load.
 - Riding on the equipment.
- Emergency lowering of vehicles must only be carried out by competent persons.
- When not in use, switch off equipment and secure main switch with padlock.

4.2 Operational safety, malfunctions

- The operational safety of the lift is to be checked regularly.
- In the case of malfunctions or missing safety-relevant components the lift is immediately to be taken out of operation. Inform a superior or authorized customer service.

4.3 Pick-up points

- Check for load capacity, corrosion, damage and modifications before applying the lifting cylinder pick-up points to the vehicle.
- Only lift vehicles on manufacturer-approved positions.
- No work, which affects the stability of the pick-up points on the lifted vehicle is permitted.

4.4 Lifting / lowering

- Only operate the lift if no persons are at risk.
- No persons are permitted within the load and pick-up area during lifting and lowering.
- After lifting just above floor level, check that the vehicle is secure. Only afterwards lift vehicle to desired height.
- The entire area below load and pick-up equipment must be free of obstructions.

4.5 Operation without controls "FOR"

- Inform persons in the lift area of the manual adjustment of the vehicle position.
- For lifts with 4, 5 or 6 lifting cylinders: Lower all vehicles which are not affected by the repair completely before activating the intended FOR function.
- For safety reasons, a second operator must be called in to permanently activate the "FOR" switch and to deactivate immediately in case of danger.
- Ensure horizontal vehicle position during lowering.

4.6 Installation, maintenance, repair

- Installation, maintenance and repair work must only be carried out with switched off and secured equipment by trained and authorized experts.
- Work on the electrical equipment must only be carried out by electricians.
- Work on hydraulic equipment must only be carried out by experts with specialist knowledge and experience.
- Repair of lift safety mechanisms must only be carried out by competent persons.
- Adhere to the maintenance schedule, record maintenance work.
- Only use original spare parts from the manufacturer.
- The lift must be inspected by authorized expert after design modifications or repair of safety-relevant components.

5. Operation



Danger of personal injury with malfunctions.

DANGER

→ Immediately switch off and secure the lift, inform a superior in case of signs of malfunctions, such as unusual noise, leakage or displayed malfunction reports.

5.1 Emergency stop



Press the Emergency stop button to immediately stop the lift in case of emergency.

Emergency stop is triggered by the

- Main switch or
- Emergency stop button on control panel

5.2 Switch on equipment

13

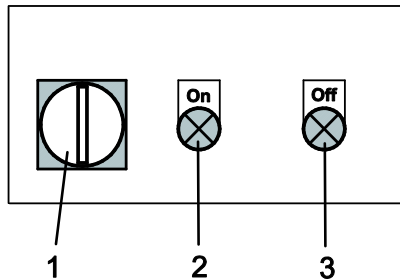

1. Switch on power supply with Main switch (1) (position "1").
2. Switch on controls with button (2).

5.3 Lift allocation (optional)

Lifts with 4, 5 or 6 lifting cylinders can be allocated to individual workplaces. a control panel is provided for each workplace.

14

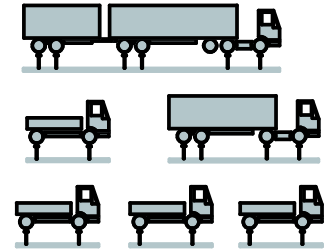
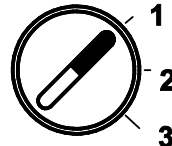

1. Allocate lift with selector switch according to Illustration 14. The allocated control panels are activated.



Different allocation can only be selected with all lifting cylinders unloaded.

5.4 Detect vehicle data

1. Determine weight specifications in vehicle registration.
2. Compare specifications with lift nominal values.
3. Determine permissible pick-up points according to manufacturer's specifications.
4. Contact a superior in case of missing vehicle specifications.



Vehicle center of gravity must be in center of vehicle; inspect load and bodywork.

5.5 Drive vehicle on lift

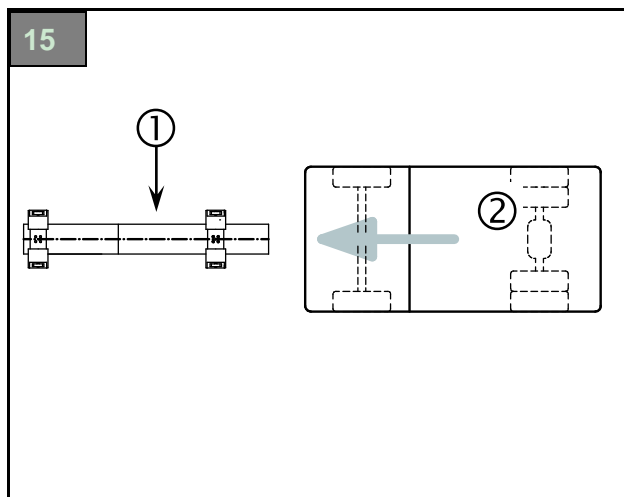

- ① Lift axis
② Vehicle

i Drive slowly over pit cover. Do not exceed maximum wheel load.
Never use cover as base to support loads.

1. Position vehicle centered on lift axis. Ensure sufficient ground clearance. Do not drive over lift components or cover.
2. Secure vehicle against inadvertent rolling.

5.6 Detect pick-up points on vehicle

- To ensure stability, pick-up points should be as far apart from each other as possible.
- The vehicle center of gravity must be on the lift axis.
- 2 pick-up points per vehicle axle are to be used.
- Check for load capacity, corrosion, damages and modifications before attaching the lifting cylinder pick-up points on the vehicle.

5.7 Select pick-up equipment

ATTENTION Vehicle damages caused by lifting with damaged pick-up points.

- Only use original pick-up points of the manufacturer.
- Select positive-fit load-bearing equipment enveloping the vehicle's load-bearing points and prevent slipping.

5.8 Attach lifting cylinders to vehicle

Start with fixed lifting cylinder.

1. Place cross members suitable for the vehicle on the pick-up points.
2. Activate respective lifting cylinder on the control (switch to "1" position). Set all other switches to the "0" position.
3. Lift the vehicle slightly with the Up **↑** button, until the indicator (→ Illustration 12, pos. 1) shows load (flashes). The lifting cylinder is in position.

i Notes

- Only lift vehicle at permissible positions according to the manufacturer. Check safe positioning after lifting slightly.
 - The vehicle must sit free on the load-bearing equipment.
 - The indicator flashes after the vehicle is lifted approx. 5cm. Buttons Up, Down and Move (**↑**, **↓**, **↔**) are now locked for this lifting cylinder.
4. Position all lifting cylinders with **←** and **→** buttons one after the other in longitudinal direction under the pick-up points and attach to vehicle, as described before.

5.9 Activate synchronous operation

1. Activate all previously set lifting cylinders on the control panel. Set respective switches to "1" position, set all other switches to "0" position. Indicator (→ Illustration 12, pos. 1) flashes.
2. Press Synchronous operation button (→ Illustration 12, pos. 2).
The indicator lights up permanently to show synchronous operation.

5.10 Lifting / lowering

i To prevent the load from shifting, lifting and lowering must be carried out evenly.

i Immediately stop all movement in case the vehicle does not stay stable.
Set the main switch to "OFF" and lock it. The vehicle must now be lowered by authorized competent person.

Lifting

1. Press Up **↑** button. Lift the entire vehicle slightly off the ground.
2. Check that the vehicle is secure.
3. Press Up **↑** button. Lift the vehicle to the desired height.

Lowering

i An alarmsounds during lowering in the danger area < 500mm.

1. Check that the vehicle is secure.
2. Ensure that no objects are left under the vehicle.
3. Press Down ↓ button. Lower the vehicle.
4. Synchronous operation ends automatically after all lifting cylinders are free of load.
5. Press Down ↓ button. Lower cross members to lowest position.

5.11 Drive vehicle off the lift

1. Secure vehicle against inadvertent rolling.
2. Ensure that all cross members are in lowest position.
3. Remove pick-up equipment.
4. Drive the vehicle off the lift. Do not drive over lift components or covers.

5.12 Switch off equipment

1. Switch off controls. Press Off button (→ Illustration 13, pos. 3).
All control panels are deactivated.
2. Switch off power supply with main switch (→ Illustration 13, pos. 1) (“OFF” position) and secure main switch with padlock.

5.13 Operation without controls “FOR”



Danger due to poorly defined responsibilities.

WARNING

- Inform all persons in the lift area that you are manually adjusting the vehicle position.
- All affected vehicles are to be lowered before the adjustment if the lift is allocated to several workplaces.
- Always work together with a second person.

- Automatic lift controls are switched off during FOR function.
- Control commands always apply to the activated lifting cylinders.

i **Adjustment of vehicle position by activation or deactivation of individual lifting cylinders.**

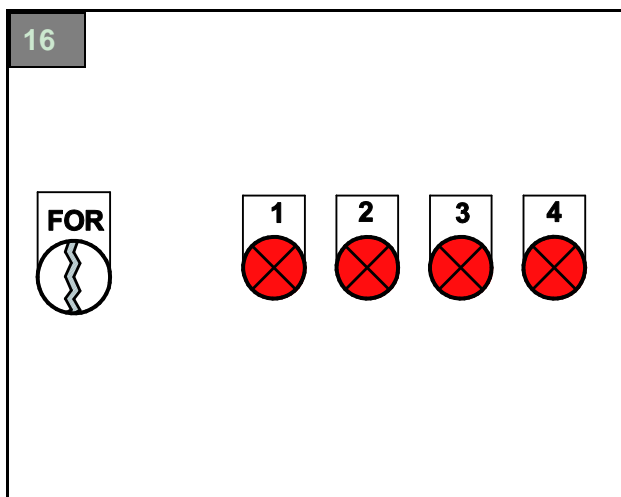

1. **Person 1 = Competent person:**
Press and hold down “FOR” button.
2. **Operator 2:**
Activate the necessary lifting cylinders on the control panel (respective switches to “1” position). Set all other switches to “0” position.
2. Bring vehicle with Up ↑ or Down ↓ buttons to desired height.

5.14 Store distance between axles – option “AAV” –

Illustrations 17 and 18: AAV controls

- Nr.** Rotary switch to store distance between axles of a certain vehicle type
- POS** Positioning button. For positioning the lifting cylinder(s) to the distance specifications. The distance was stored for the vehicle type by an authorized person.
- SP** For storing the distances between axles of frequently used vehicle types. For authorized persons, only with key switch.
- BT** Control panel (1 or 2)

Save

1. Drive vehicle onto the lift, check pick-up points on the vehicle and select load points (→ chapters 5.5, 5.6 and 5.7).
2. Position and adjust the lifting cylinders precisely under vehicle axles (→ chapter 5.8).
3. Select memory preset with rotary switch “Nr.”. Distances between axles for up to 9 vehicles can be stored (option available for 18 or 27 vehicles).
4. Store distance between axles with key switch “SP”.
5. Enter vehicle type in list.

Retrieve distance between axles

1. Select desired vehicle type with rotary switch “Nr.”.
2. Press and hold “POS”, “Pos BT1” or “Pos BT2” switch until the lifting cylinders have moved into position.
3. Drive the vehicle on the lift.
4. Position and set up the lifting cylinders exactly under vehicle axles (→ chapter 5.8).
5. Lift vehicle slightly off the ground. Check exact lifting cylinder position.

Control lift with 1 control panel

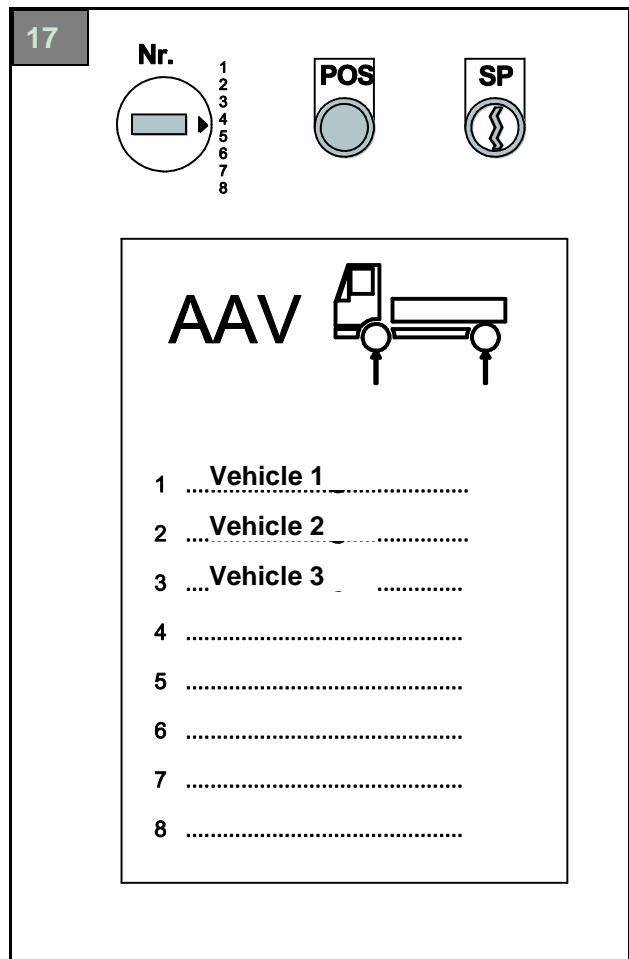

Control lift with 2 control panels

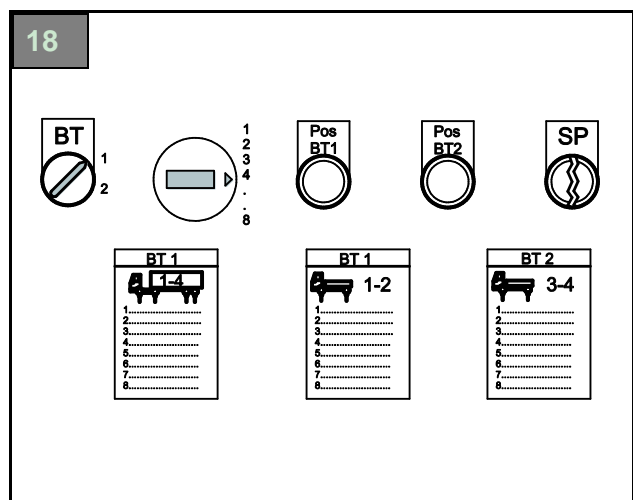

6. Malfunctions

- Check the lift for the following causes of malfunction.
- Contact the manufacturer's customer service if the malfunction cannot be remedied according to the malfunctions list.

Lift cannot be switched on

Cause: No power supply.

Remedy: Switch on power supply.

Cause: Main switch not switched on.

Remedy: Switch on main switch.

Cause: Emergency Off button pressed.

Remedy: Unlock Emergency Off button.

Lift switched on. No response to Up/Down.

Cause: Synchronous operation not activated.

Remedy: Activate synchronous operation.

Cause: Error message on control unit.

Remedy: Localize and remedy malfunction according to list in chapter 7, then acknowledge error message. Contact customer service, if necessary.

Cause: Control button is defective.

Remedy: Replace control button.

Cause: Cable damaged.

Remedy: Check cable and contact customer service, if necessary.

Lift switched on. No response to Forward/Back.

Cause: Lifting cylinder under load.

Remedy: Lower load completely.

Cause: Lifting cylinder extended more than 300mm.

Remedy: Lower all lifting cylinders under 300mm.

Cause: Error message in controls.

Remedy: Localize and remedy malfunction according to list in chapter 7, then acknowledge error message. Contact customer service, if necessary.

Cause: Control button is defective.

Remedy: Replace control button.

Cause: Cable damaged.

Remedy: Check cable and contact customer service, if necessary.

Motor is running. Vehicle cannot be lifted.

Cause: Vehicle too heavy.

Remedy: Offload vehicle. Refer to permissible load distribution in chapter 3.1.

Cause: Leakage in hydraulic system.

Remedy: Contact customer service.

Cause: Hydraulic oil level too low.

Remedy: Refill hydraulic oil.

Vehicle cannot be lowered.

Cause: Synchronous operation not activated.

Remedy: Activate synchronous operation.

Cause: Error message in controls.

Remedy: Localize and remedy malfunction according to list in chapter 7, then acknowledge error message. Contact customer service, if necessary.

Cause: No power supply.

Remedy: Switch on power supply.

Cause: Main switch not switched on.

Remedy: Switch on main switch.

Cause: Emergency Off button pressed.

Remedy: Unlock Emergency Off button.

6.1 Emergency lowering

- Vehicle emergency lowering only to be carried out by competent persons.



DANGER

Danger to life due to electric shock while working on open control cabinet.

- Only electricians are permitted to work on the open control cabinet.
- Never touch live components.

Emergency lowering during power failure

1. Wait for the end of the power failure, if possible.
2. Then lower the vehicle in normal operation.

i If there is no power supply, the vehicle can be lowered by connecting a 24 V external power supply.

1. Connect external power supply 24VDC, 6A according to circuit diagram on control cabinet (e.g. truck or forklift battery).
2. Switch on lift.
3. Switch on synchronized operation.
4. Lower the vehicle slowly as described in chapter 5.13 "Operation without controls".
5. Remove external power supply.
6. Have malfunction repaired by electrician.

Lift secured during malfunction. Condition cannot be acknowledged.

1. Check according to malfunction list in chapter 7 if "FOR" mode is permissible.
2. If permitted, lower the vehicle slowly as described in chapter 5.13 "Operation without controls".
3. Clear malfunction. Contact authorized customer service, if necessary.

Lowering with FOR with defective solenoid valve

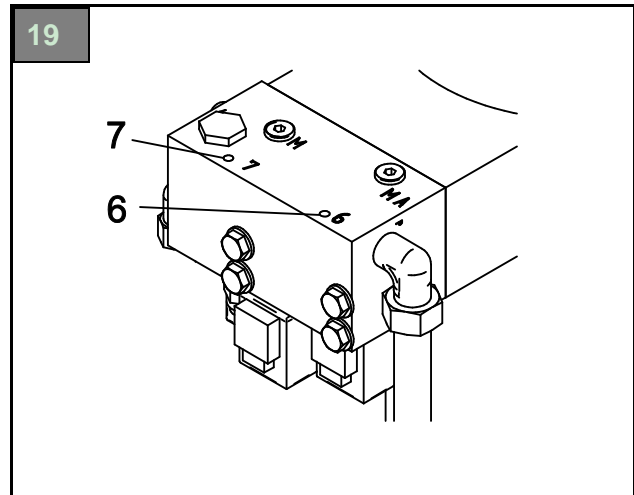

1. Correct horizontal vehicle position with lifting button (→ chapter 5.13, Operation without controls).
2. Open the maintenance door on the defective lifting cylinders to have free access to hydraulic components.
3. Loosen locking screw (6) approx. 2 turns. The load does not lower.
4. Exit danger area under the vehicle.
5. Lower the vehicle slowly as described in chapter 5.13 "Operation without controls".
6. Drive vehicle from the lift.
7. Close locking screw (6) again.
8. Attach protective cover and close maintenance door.
9. Have malfunction repaired by electrician.

7. Malfunction reports

7.1 Malfunction indicator lamps

- Malfunctions are indicated by means of 4 malfunction indicator lamps L1 to L4 on the control cabinet.
- Operating functions on the respective control panel are locked until the malfunction is rectified.

Acknowledge malfunction rectification after repair as follows:

1. Turn off the equipment with the main switch.
2. Turn the equipment back on afterwards.



Contact the authorized customer service if the malfunction is not rectified after the specified corrective actions.

Malfunction indicator V2.17 02/2011

Nr	L1	L2	L3	L4	Malfunction report	FOR possible
	■	■	■	■	Lamp test after switching on, approx. 5 seconds.	
1	■	■	■	■	Emergency stop or equipment switched off. On board 4 LEDs light up red.	no
2	■	■	■	■	Motor overload switch has been triggered.	yes
3	■	■	■	■	Malfunction on electronics board: ADC, voltage or CAN bus error.	no
3	■	■	■	■	FLASHES: Calibration error (sensors) or flash memory error.	yes
4	■	■	■	■	Power output too hot or short circuit.	no
5	■	■	■	■	Low oil level.	yes
6	■	■	■	■	Cable break for level sensor.	yes
7	■	■	■	■	Defective level sensor in oil tank.	yes
8	■	■	■	■	Defective travel sensor AAV.	yes
9	■	■	■	■	Defective push button (Up, Down, Forward or Back).	no
10	■	■	■	■	No lift change after movement command (speed = 0).	yes
11	■	■	■	■	Direction monitoring lifting / lowering.	yes
12	■	■	■	■	Breakdown monitoring	no
13	■	■	■	■	Positioning error (no target values stored).	yes
13	■	■	■	■	FLASHES: Error AAV, movement locked (e.g. lift > 300, cylinder loaded).	yes
14	■	■	■	■	Synchronous run error: Maximum control difference exceeded.	yes
15	■	■	■	■	FLASHES: Change in lift allocation not possible under load.	yes
16	■	■	■	■	Contouring error.	yes

8. Maintenance

8.1 Qualification maintenance staff

Maintenance only to be carried out by competent persons (→ chapter 1.3).

8.2 Safety precautions

- Maintenance and repair work only to be carried out with switched off and secured equipment.
- Work on the electric equipment only to be carried out by electricians.
- Work on hydraulic equipment only to be carried out by experts with specialized knowledge and experience. Observe attached unit operating instructions in Annex.
- Attach warning sign “Restricted for maintenance” before start of work and secure lift area with a red and white chain.
- Inform all persons in the lift area about the maintenance work.
- Maintenance and repair work only to be carried out on unloaded lift.
- Adhere to the maintenance schedule, record maintenance work (→ maintenance report).
- Only use original spare parts from the manufacturer.
- The lift must be inspected by an authorized expert after design modifications or repair of safety-relevant components.
- Tighten bolts after maintenance according to torque specifications.
- Prevent environmental hazards.
- Observe environmental disposal regulations (→ chapter 15.2).
- Avoid contact with or inhaling of toxic substances, such as hydraulic oil.
- Wear protective clothing, e.g. goggles, protective gloves, etc.
- Danger of suffocation in unventilated pit. Ventilate pit adequately before start of work. Do not work alone in the pit. Ensure adequate lighting.

8.3 Maintenance schedule



Clean and maintain lifts in particularly dirty surroundings more often.



Ventilate pit adequately before start of work. Ensure adequate lighting.

Daily

1. Lower the lift after work completely and secure against unauthorized use.
2. Clean lift and work area.

Monthly

1. Check hydraulic oil level (→ chapter 8.5).
2. Check controls for function, cables for damages.
3. Open maintenance door, check cables in pit for damages.
4. Check hydraulic components for leakages (→ chapter 8.7).
5. Tighten mounting screws of cross members and shafts to the specified torque (→ chapter 8.8).
6. Lubricate rollers.
7. Check indicator lamps (→ chapter 8.10).
8. Carry out function test without and with load (→ chapter 8.11).

Annually

1. Carry out safety inspection (→ chapter 10).
2. Check safety cylinder function (→ chapter 8.12).
3. Regularly check motor protection setting.

Biannually

1. Change oil (→ chapter 8.14).

8.4 Cleaning

- Clean lift regularly.
- Clean lift only in unloaded condition.
- Do not use aggressive cleaning agents for lift components and covers.
- Only use lint-free cleaning cloths.
- Do not use compressed air or high-pressure cleaners.
- Always call in the appointed maintenance representative if hazards are detected.
- At the start of cleaning, make sure you clean connections and screw joints of oil, lubricants and cleaning agents.

8.5 Check hydraulic oil level



Check oil levels on all lifting cylinders.

1. Lower all lifting cylinders completely.
2. Remove dipsticks and check hydraulic oil level.
3. Refill hydraulic oil (→ chapter 8.6) up to filling level, if necessary.
4. Replace dipstick.
5. Calibrate the sensor setting after every intervention in the hydraulic system (→ chapter 8.13).

8.6 Permitted hydraulic oils



Important notes

- Only use hydraulic oil according to DIN 51524 for the hydraulic system.
- Contact us when using hydraulic oil of other manufacturers.
- Oil and lubricants are hazardous to water. Always dispose of these substances in an environmentally friendly manner according to the regulations in your country (→ chapter 15, Disposal).

ATTENTION Damage to seals with use of incorrect hydraulic oil.

- Do not use oil based on rapeseed oil.
- The water content in the oil is not to exceed 2%.
- Do not mix different types of oil.

Manufacturer	Oil type
ARAL	Vitamin
BP	Energol HLP 22, HLP-D 22
ESSO	ESSTIC 22, Nuto H22
FINA	Hydran 22, Circan 22
FUCHS	Renolin MR, Renolin B
MOBIL OIL	Mobil D.T.E
SHELL	Hydrol DO 22
TEXACO	Rando Oil 22, -HDC-22
VALVOLINE	ETC
VEDOL	Andarin 22

8.7 Check hydraulic components for leakages

i Check lift only in unloaded condition.

1. Carry out visual check of rod seals and scraper rings (→ chapter 9.1) at stages 1 and 2 during lifting and lowering.
2. Switch off lift with main switch and secure with padlock.
3. Open maintenance door.
4. Open protective cover.
5. Check all hydraulic components for leakage.
6. Replace and tighten protective cover.
7. Close maintenance door.
8. Remove padlock, switch on lift.

Tightening torque for bolts

For set screws, friction factor = 0,125

Dimensions	Tightening torque (Nm)		
	Strength category		
	8.8	10.9	12.9
M 4	2.8	4.1	4.8
M 5	5.5	8.1	9.5
M 6	9.6	14	16
M 8	23	34	40
M 10	46	67	79
M 12	79	115	135
M 14	125	185	220
M 16	195	290	340
M 18	280	400	470
M 20	395	560	660
M 22	540	760	890
M 24	680	970	1150
M 26	1000	1450	1700
M 30	1350	1950	2300

8.8 Tighten mounting screws of cross members and shafts

1. Check tightening torque with torque spanner and re-tighten, if necessary:
 - Bolts on cross member: M20 with 560Nm
 - Bolts on shafts: M16 with 195Nm

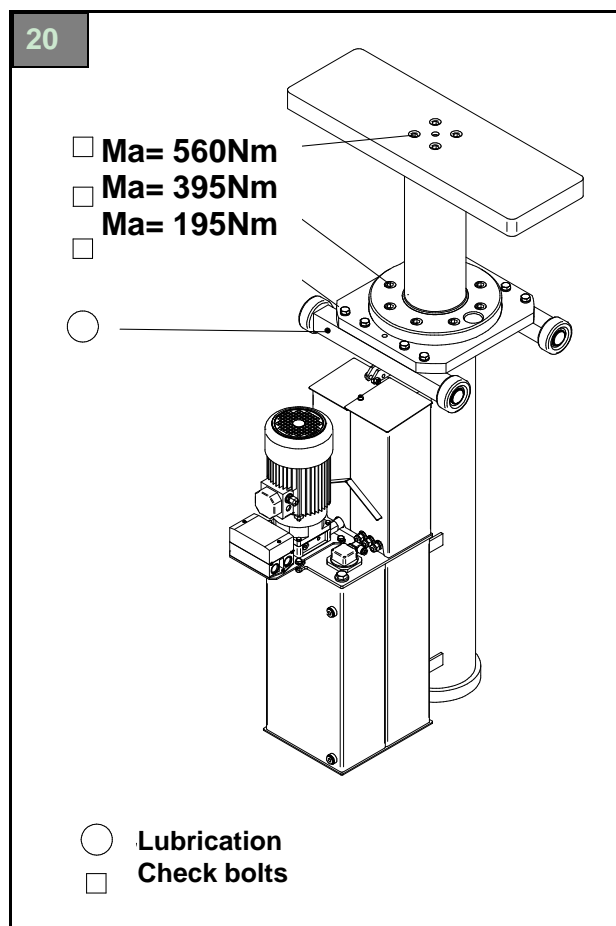

8.9 Bleed lifting cylinder

- Always bleed lifting cylinder unloaded.
- Each lifting cylinder has 3 bleeding positions.

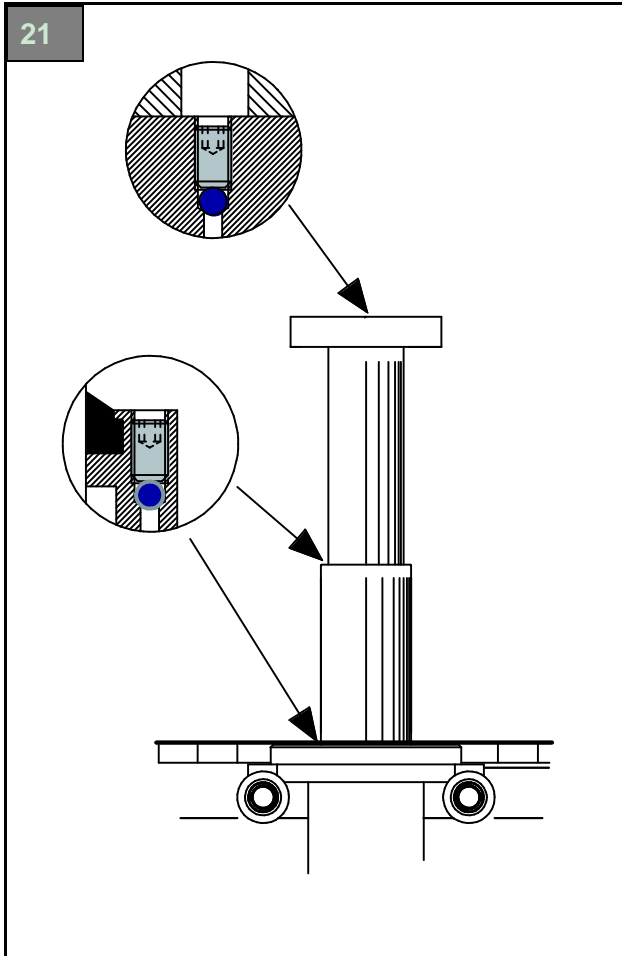

1. Extend plunger rods approx. 1m.
2. Extend further and bleed all three positions during lifting and lowering, starting at the bottom.
Loosen bleeding screw approx. 1 turn until oil escapes without bubbles; then close again.

8.10 Check indicator lamps

1. Switch on lift with main switch.
2. Switch on controls with On switch.
All 4 malfunction indicator lamps light up for 1 second.
3. Switch lift off again.

8.11 Carry out function test



Danger of personal injury through malfunctions.

WARNING

- Deactivate and secure lift immediately after detecting malfunctions.
- Rectify malfunctions immediately and ensure trouble-free operation.

1. Check lift function without load.
2. Check full lift function with load

8.12 Check safety cylinders



Check safety cylinders annually. Strictly observe test interval.



DANGER

Danger to life due to electric shock when working on open control cabinet.

- Only electricians are permitted to work on open control cabinet.
- Never touch live components.

1. Lift vehicle 1.85m and measure initial height.
2. Check safety cylinders: Open control cabinet and press and hold button "1" approx. 1 min.

All solenoid valves of the working cylinders are opened. The safety cylinders carry the entire load.



Initially the load drops a little (maximum 100mm). Afterwards it must come to a stop with activated button.

3. Measure vehicle height again and note the drop travel on each axle.
4. Check working cylinders: Press and hold button "2" (Illustration 22) approx. 1 min.

All solenoid valves of the safety cylinders are opened. The working cylinders carry the entire load.

i Initially the load drops a little (maximum 100mm). Afterwards it must come to a stop with activated button.

5. Measure vehicle height again and note the drop travel on each axle.

8.13 Calibrate sensor setting

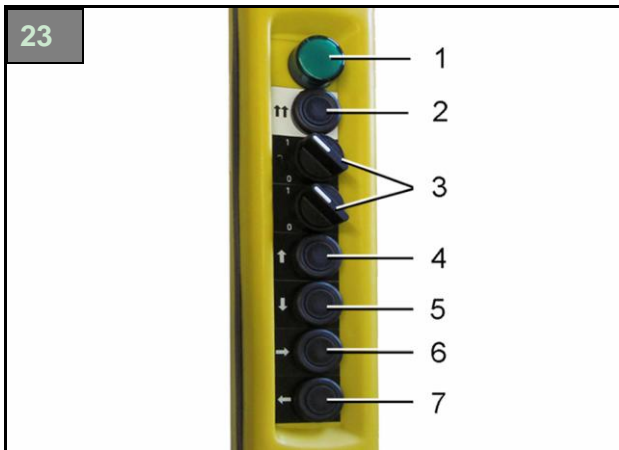

1. Lower all lifting cylinders to lowest position.
2. Set all lifting cylinder activating switches (3) to zero.
3. Press and hold Synchronous operation (2) and Back (7) buttons for approx. 10 seconds.
4. Press and hold Up (4) and Forward (6) buttons for approx. 10 seconds.
5. Press and hold Down (5) and Back (7) buttons for approx. 10 seconds.

The sensors are now calibrated.

8.14 Change hydraulic oil

- Always change the hydraulic oil for all lifting cylinders.
- Permitted hydraulic oil:
Hydraulic oil with viscosity 22 cST/40° and quality HLP DIN51524 T2.
- Required amount of oil:
65 l per lifting cylinder.

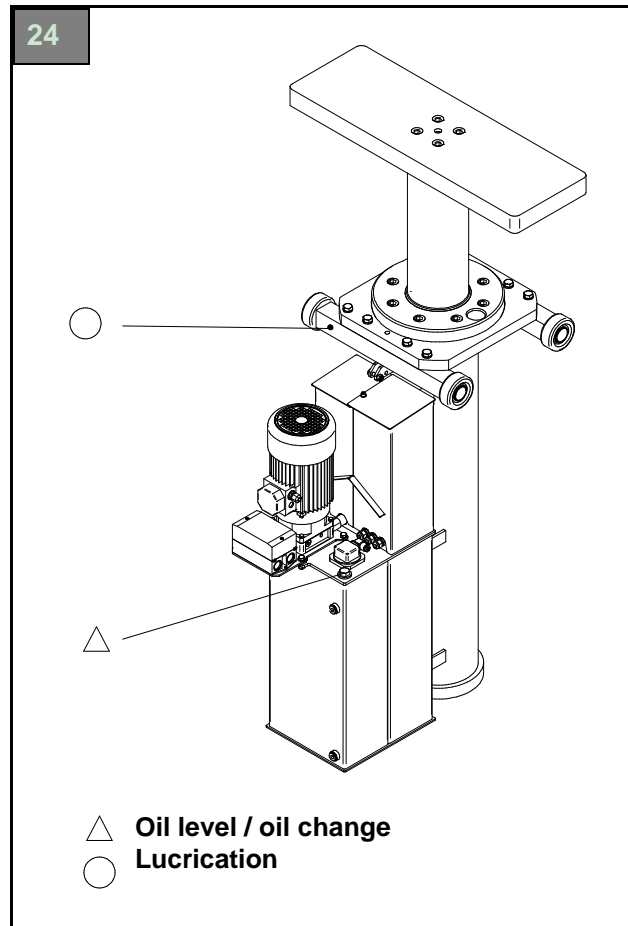

1. Lower all lifting cylinders completely, switch off and secure lift.
2. Open maintenance door and cover.
3. Remove dipstick.
4. Extract waste oil.
5. Fill fresh hydraulic oil up to the specified marking.
6. Replace dipstick.
7. Bleed lifting cylinder.
8. Check oil level.
9. Dispose of waste oil professionally according to chapter 15.

9. Repair

- Repair work only to be carried out by authorized staff with the equipment switched off and secured
- **Observe safety precautions in chapter 8.2.**
- All repair work is to be recorded (→ form “Special safety check”).

9.1 Change gaskets

Cause for defective seals can be for instance:

- Damaged plunger rods
- Lip seal wear through dirt
- Ageing seal

After changing the gaskets

1. Bleed lifting cylinder
2. Check oil level
3. Calibrate sensors

Change seal and scraper ring Ø180mm (Illustration 25)

1. Lower lifting cylinder completely.
2. Turn off and secure equipment.
3. Detach cross member (forklift, crane).
4. Remove the 8 bolts (1) and detach flange (4).
5. Change seal ring (3) and scraper ring (2).
6. Replace O-ring (5) on flange.
7. Attach flange (tightening torque bolts: $M_a = 395\text{Nm}$).
8. Attach cross member (tightening torque bolts: $M_a = 560\text{Nm}$).

Change seal and scraper ring Ø150mm (Illustration 26)

1. Lower lifting cylinders to 50mm above floor level.
2. Detach cross member (forklift, crane).
3. Lower with Down button, at the same time knock down plunger rod Ø150 carefully with plastic hammer), until seal and scraper are freely accessible.

25

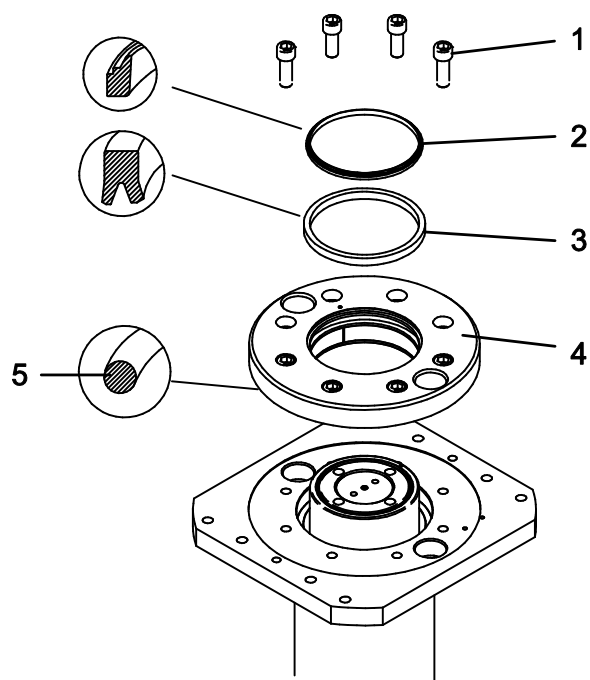

26

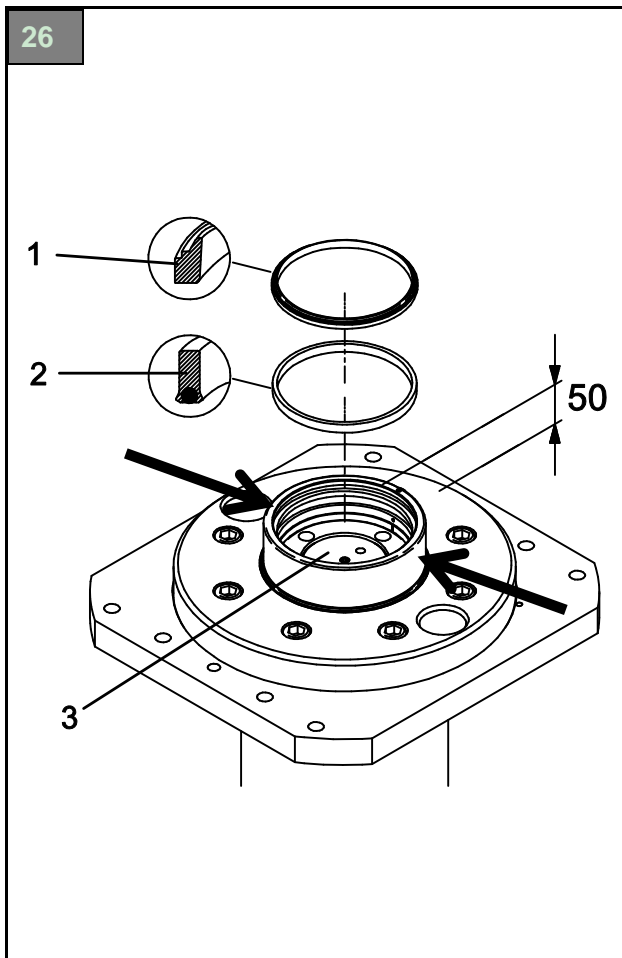

4. Turn off equipment.
5. Change seal ring (2) and scraper ring (1).
6. Replace cross member, tighten plunger rod \varnothing 150mm with mounting screws on cross member (tightening torque bolts: $M_a = 560\text{Nm}$).

10. Safety checks

Safety checks are necessary to ensure the safety of the lift during operation.

Carry out safety checks in following cases:

- **Initial start-up:** Use form "First safety check before start-up".
- **Annually:** Use form "Annual safety check".
- **Special safety check:**
After every design modification of lift components. Use form "Special safety check".

Safety checks are only to be carried out by authorized experts or competent persons.

11. Transport, storage

11.1 Storage

Lift components are only to be stored dry (no corrosion protection).

Permitted storage conditions

- Ambient temperature: $-5 \dots +50^\circ\text{C}$
- Relative humidity, 30% ... 95%
not condensing, at 20°C

i The manufacturer is not responsible for corrosion damage due to incorrect storage.

11.2 Transport



Danger of crushing and shearing off of limbs during offloading due to falling or shifting of the load.

DANGER

- Do not linger in the vicinity or under suspended loads.
- Offload and transport packaging units to installation location only with forklift or pallet lift with sufficient load capacity.
- Only use load-bearing equipment (slings, chains, etc.) permitted for the total weight.
- Attach load-bearing equipment in such way that slipping is impossible (observe load center of gravity).
- Attach individual components only at load-bearing parts. Lift only vertically, even and with smooth movements.
- Carry out visual check before offloading.
- Secure loose components.
- Always be aware of the danger zones during lifting and lowering.
- Transport hydraulic components always without oil filling.

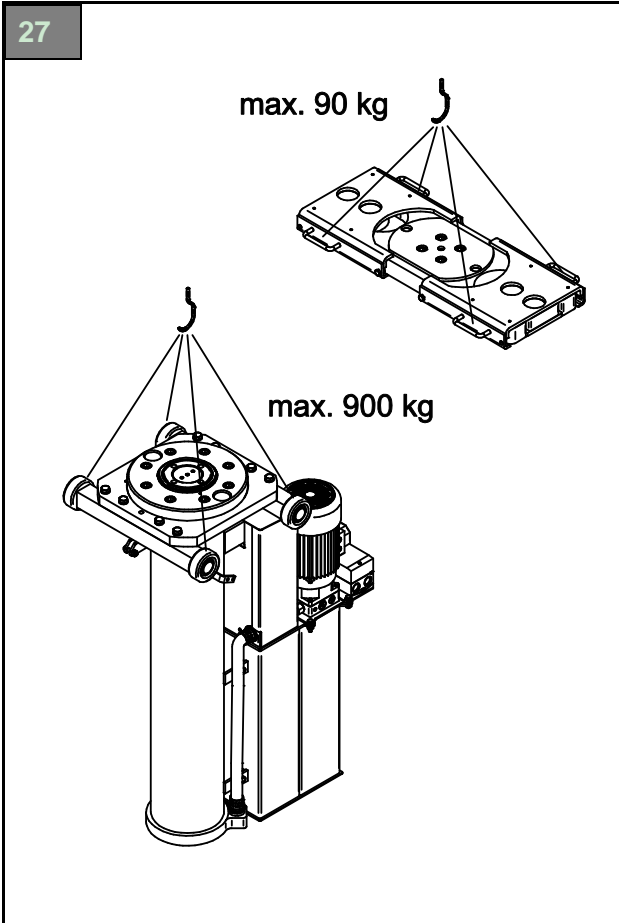

12. Setting up

12.1 Set-up regulations

- Lift set-up is carried out by trained technicians of the manufacturer or authorized dealer.
- The standard design lift must not be positioned in explosive areas.
- Before set-up an adequate foundation must be verified. Alternatively, this can be built according to the foundation guidelines.
- Permissible tolerances for concreted foundation frame:
 - Evenness $\pm 1\text{mm}$ ● Parallelism $\pm 1\text{mm}$
- The foundations must be carried out to freeze depth if frost or winter weather can be expected at the location.
- The technical data in chapter 3.2 must be followed.

12.2 Electric connection

- Electric connections and protective measures must be carried out by an authorized expert according to applicable regulations in your country.
- A main fuse must be connected upstream of the lift.

Number of lifting cylinders	3 + N + PE 50Hz, 400V			
	Rated power [KW]	Rated current [A]	Main fuse [A]	Connecting cable [mm ²]
1	4.5	10	16	5G2.5
2	9	20	35	5G6
3	13.5	30	35	5G10
4	18	40	50	5G10
5	22.5	45	63	5G16
6	27	60	63	5G16

- Local conditions apply for selecting the protective measures.
- Specified connecting cable cross sections are reference values for maximum cable length 50m at 30°C temperature.
- “Slow-blow” fuses are to be used.

12.3 Set-up remarks

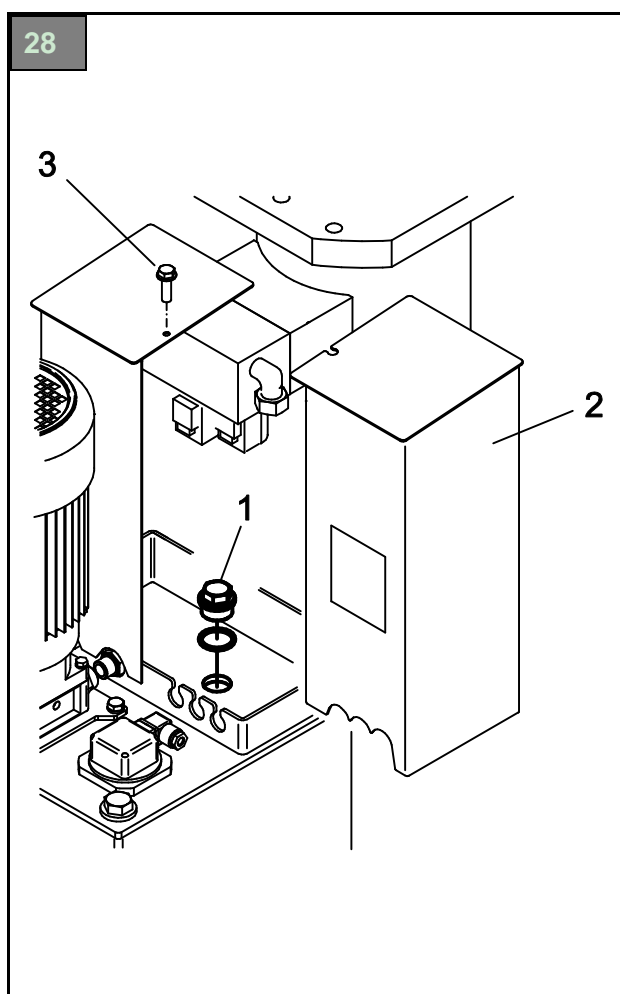

Install bleeder filters before installing lifting cylinders.

1. Loosen screw (3).
2. Open cover (2).
3. Replace locking screw (1) with bleeder filter.
4. Tighten cover (2) with screw (3).
5. Remove padlock and switch on lift.
6. Record correct installation in inspection book. Use form “First safety check before start-up”.

13. Start-up

i Carry out "Safety check" before start-up.

If a competent person (factory-trained technician) installs the lift, this person also carries out the safety check.

If the operator organizes the set-up, a competent person has to carry out the safety check.

The competent person fills out the forms "Set-up protocol" and "First safety check before start-up" and confirms the trouble-free lift function. The lift is now approved for operation.

i The set-up protocol must be sent to the manufacturer after start-up.

14. Disassembly

- Disassembly work must only be carried out by authorized experts.
- Electric work must only be carried out by electricians.
- Work on hydraulic or pneumatic equipment must only be carried out by trained persons with hydraulics/pneumatics knowledge.
- Hydraulic oil, lubricants, cleaning agents and spare parts must be disposed of according to environmental regulations.
- Environmental disposal regulations must be complied with (→ chapter 15.2). Environmental hazards must be prevented.
- Equipment components must be disposed of according to your local regulations.

15. Disposal

15.1 Packaging materials

Do not dispose of with the residual waste! The packaging party contains recyclable materials, which must not be disposed of with general waste.

1. Dispose of packaging materials according to local regulations.

15.2 Environmental disposal regulations

- Avoid environmental hazards.
- Avoid contact or inhalation of toxic substances, such as hydraulic oil.
- Oil and grease are hazardous to water under the provisions of the Federal Water Act (WGH). Always dispose of these substances in an environmentally friendly manner according to your local regulations.
- Hydraulic oil on mineral material base is hazardous to water and flammable. Refer to the respective safety data sheet for disposal.
- Provide suitable containers for waste oil and oil binding agents.
- Ensure that no hydraulic oil, lubricants or cleaning agents contaminate the soil or get into the drainage system.

15.3 Metal / electronic scrap

- Professional disposal is only permitted through certified companies.

ANNEX

Inspection book with

- Master data sheet DUPLEX-S2 lift
- Form "Set-up protocol"
- Form "Handover certificate"
- Form "First safety check before start-up"
- Form "Annual safety check".
- Form "Special safety check"
- Maintenance report

Diagrams, spare part lists

- Electrical circuit diagram → see control cabinet
- Hydraulic circuit diagram
- Spare parts lists

Master data sheet DUPLEX-S2 lift

Manufacturer
 BlitzRotary GmbH
 Hüfinger Str. 55
 78199 Bräunlingen
 Germany

Lift
 Type
 Serial number

Intended use

- The lift is intended for lifting and lowering commercial vehicles for repair, maintenance and cleaning during normal workshop operation.
- The lift is only to be used as intended, in technically sound condition according to technical specifications in chapter 3.2.
- The maximum load capacity of one lifting cylinder is 15 000 kg and is not to be exceeded.
- The permissible load distribution in or against drive direction is 2:1.
- Standing or working under suspended load is permitted.
- Misuse: Improper behavior can cause danger for life and health of persons working in the vicinity of the lift. The manufacturer is not responsible for damages caused by use against regulations and misuse. Standing and riding on load and pick-up equipment, standing or working under the suspended load during lifting and lowering, lift installation in explosive areas and lifting of vehicles loaded with hazardous goods is prohibited.
- Supplied pick-up equipment (axle cross members) are not adjusted for specific vehicle types. They are part of the basic configuration.
- The lift must be inspected by authorized expert after design modifications or repair of load-bearing components. This also applies after moving the equipment to a different installation location. Modifications are to be carried out by competent person and are to be recorded in the set-up report.

Design modifications: Start-up inspection by competent person

Following modifications were carried out:

.....
 Date, place Name of authorized expert Signature of authorized expert

Change of installation location: Start-up inspection by competent person

Following modifications were carried out:

.....
 Date, place Name of authorized expert Signature of authorized expert

Set-up protocol

BlitzRotary GmbH
 Hüfänger Str.55
 78199 Bräunlingen,
 Germany

- Complete this form in full after successful installation, tick the appropriate boxes and sign the form.
- Copy the original and send it within one week to the manufacturer.
- Leave a copy in the inspection book.

The in-ground truck lift Duplex-S2,

Type

Machine/serial number:

was installed on

at

(address)

checked for functionality and safety and was commissioned.

Installation was carried out by operator / competent person

The operator verifies the set-up of the lift. All information in these operating instructions and the inspection book have been read and understood. The documentation is available to the operators at all times.

The competent person verifies the correct lift installation. All information in the operating instructions and the inspection book have been read. The documentation was handed over to the operator.

.....
Date	Name of operator + company stamp	Signature of operator

.....
Date	Name of competent person	Signature of competent person

.....

Customer service partner

Handover report

The in-ground truck lift Duplex-S2,

Type

Machine/serial number:

was installed on

at
(address)

checked for functionality and safety and was commissioned.

The following persons (operators) were trained after lift installation by a trained manufacturer's or authorized dealer's technician (competent person) in operating the in-ground lift.

.....
Date	Name	Signature of operator

.....
Date	Name	Signature of operator

.....
Date	Name	Signature of operator

.....
Date	Name	Signature of operator

.....
Date	Name	Signature operator

.....
Date	Name	Signature competent person

.....
Customer service partner

First safety check before start-up only by competent person

Keep completed form in inspection book (Annex)!

Carry out the following test steps.
Tick if appropriate.

Type

Serial number:

Step-by-step safety check	Ok	Fault	Miss- ing	Check again	Remarks
Short instruction manual	<input type="checkbox"/>	<input type="checkbox"/>	<input type="checkbox"/>	<input type="checkbox"/>	
Type label	<input type="checkbox"/>	<input type="checkbox"/>	<input type="checkbox"/>	<input type="checkbox"/>	
Warning signs	<input type="checkbox"/>	<input type="checkbox"/>	<input type="checkbox"/>	<input type="checkbox"/>	
Function lifting / lowering	<input type="checkbox"/>	<input type="checkbox"/>	<input type="checkbox"/>	<input type="checkbox"/>	
Condition of pick-up equipment	<input type="checkbox"/>	<input type="checkbox"/>	<input type="checkbox"/>	<input type="checkbox"/>	
Function moving lifting cylinder	<input type="checkbox"/>	<input type="checkbox"/>	<input type="checkbox"/>	<input type="checkbox"/>	
Condition of welding seams	<input type="checkbox"/>	<input type="checkbox"/>	<input type="checkbox"/>	<input type="checkbox"/>	
General lift condition	<input type="checkbox"/>	<input type="checkbox"/>	<input type="checkbox"/>	<input type="checkbox"/>	
Condition of structural components	<input type="checkbox"/>	<input type="checkbox"/>	<input type="checkbox"/>	<input type="checkbox"/>	
Condition of controls	<input type="checkbox"/>	<input type="checkbox"/>	<input type="checkbox"/>	<input type="checkbox"/>	
Condition of control panel	<input type="checkbox"/>	<input type="checkbox"/>	<input type="checkbox"/>	<input type="checkbox"/>	
Check pick-up lift components (distortion, cracks)	<input type="checkbox"/>	<input type="checkbox"/>	<input type="checkbox"/>	<input type="checkbox"/>	
Condition of lifting cylinder	<input type="checkbox"/>	<input type="checkbox"/>	<input type="checkbox"/>	<input type="checkbox"/>	
Test screws torque	<input type="checkbox"/>	<input type="checkbox"/>	<input type="checkbox"/>	<input type="checkbox"/>	
Function safety mechanisms	<input type="checkbox"/>	<input type="checkbox"/>	<input type="checkbox"/>	<input type="checkbox"/>	
Condition of covers	<input type="checkbox"/>	<input type="checkbox"/>	<input type="checkbox"/>	<input type="checkbox"/>	
Hydraulic system leak-proof	<input type="checkbox"/>	<input type="checkbox"/>	<input type="checkbox"/>	<input type="checkbox"/>	
Fill level of hydraulic tank	<input type="checkbox"/>	<input type="checkbox"/>	<input type="checkbox"/>	<input type="checkbox"/>	
Condition of hydraulic hoses	<input type="checkbox"/>	<input type="checkbox"/>	<input type="checkbox"/>	<input type="checkbox"/>	
Condition of electrical cables	<input type="checkbox"/>	<input type="checkbox"/>	<input type="checkbox"/>	<input type="checkbox"/>	
Function test loaded lift	<input type="checkbox"/>	<input type="checkbox"/>	<input type="checkbox"/>	<input type="checkbox"/>	

Safety check carried out

Result

Date:

Further operation inadvisable, re-inspection necessary

Company:

Further operation possible, rectify faults

Competent person (name, address)
.....

Further operation without objections, lift faultless

.....
Signature of operator

.....
Signature of competent person

Faults remedied on

Use different form for re-inspection!

.....
Signature of operator

.....
Signature competent person

Annual safety check only by competent person

**Keep completed form
in inspection book
(Annex)!**

**Carry out the following test steps.
Tick if appropriate.**

Type

Serial number:

Step-by-step safety check	Ok	Fault	Miss- ing	Check again	Remarks
Short instruction manual	<input type="checkbox"/>	<input type="checkbox"/>	<input type="checkbox"/>	<input type="checkbox"/>	
Type label	<input type="checkbox"/>	<input type="checkbox"/>	<input type="checkbox"/>	<input type="checkbox"/>	
Warning signs	<input type="checkbox"/>	<input type="checkbox"/>	<input type="checkbox"/>	<input type="checkbox"/>	
Function lifting / lowering	<input type="checkbox"/>	<input type="checkbox"/>	<input type="checkbox"/>	<input type="checkbox"/>	
Condition of pick-up equipment	<input type="checkbox"/>	<input type="checkbox"/>	<input type="checkbox"/>	<input type="checkbox"/>	
Function of moving lifting cylinder	<input type="checkbox"/>	<input type="checkbox"/>	<input type="checkbox"/>	<input type="checkbox"/>	
Condition of welding seams	<input type="checkbox"/>	<input type="checkbox"/>	<input type="checkbox"/>	<input type="checkbox"/>	
General lift condition	<input type="checkbox"/>	<input type="checkbox"/>	<input type="checkbox"/>	<input type="checkbox"/>	
Condition of structural components	<input type="checkbox"/>	<input type="checkbox"/>	<input type="checkbox"/>	<input type="checkbox"/>	
Condition of controls	<input type="checkbox"/>	<input type="checkbox"/>	<input type="checkbox"/>	<input type="checkbox"/>	
Condition of control panel	<input type="checkbox"/>	<input type="checkbox"/>	<input type="checkbox"/>	<input type="checkbox"/>	
Check pick-up lift components (distortion, cracks)	<input type="checkbox"/>	<input type="checkbox"/>	<input type="checkbox"/>	<input type="checkbox"/>	
Condition of lifting cylinder	<input type="checkbox"/>	<input type="checkbox"/>	<input type="checkbox"/>	<input type="checkbox"/>	
Test screws torque	<input type="checkbox"/>	<input type="checkbox"/>	<input type="checkbox"/>	<input type="checkbox"/>	
Function safety mechanisms	<input type="checkbox"/>	<input type="checkbox"/>	<input type="checkbox"/>	<input type="checkbox"/>	
Condition of covers	<input type="checkbox"/>	<input type="checkbox"/>	<input type="checkbox"/>	<input type="checkbox"/>	
Hydraulic system leak-proof	<input type="checkbox"/>	<input type="checkbox"/>	<input type="checkbox"/>	<input type="checkbox"/>	
Fill level of hydraulic tank	<input type="checkbox"/>	<input type="checkbox"/>	<input type="checkbox"/>	<input type="checkbox"/>	
Condition of hydraulic hoses	<input type="checkbox"/>	<input type="checkbox"/>	<input type="checkbox"/>	<input type="checkbox"/>	
Condition of electrical cables	<input type="checkbox"/>	<input type="checkbox"/>	<input type="checkbox"/>	<input type="checkbox"/>	
Function test with lifted vehicle	<input type="checkbox"/>	<input type="checkbox"/>	<input type="checkbox"/>	<input type="checkbox"/>	

Safety check carried out

Date:

Company:

Competent person (name, address)
.....

.....
Signature of operator

Result

Further operation inadvisable, re-inspection necessary

Further operation possible, rectify faults

Further operation without objections, lift faultless

.....
Signature of competent person

Faults remedied on

Use different form for re-inspection!

.....
Signature of operator

.....
Signature of competent person

Annual safety check only by competent person

Keep completed form
in inspection book
(Annex)!

Carry out the following test steps.
Tick if appropriate.

Type

Serial number:

Step-by-step safety check	Ok	Fault	Miss- ing	Check again	Remarks
Short instruction manual	<input type="checkbox"/>	<input type="checkbox"/>	<input type="checkbox"/>	<input type="checkbox"/>	
Type label	<input type="checkbox"/>	<input type="checkbox"/>	<input type="checkbox"/>	<input type="checkbox"/>	
Warning signs	<input type="checkbox"/>	<input type="checkbox"/>	<input type="checkbox"/>	<input type="checkbox"/>	
Function lifting / lowering	<input type="checkbox"/>	<input type="checkbox"/>	<input type="checkbox"/>	<input type="checkbox"/>	
Condition of pick-up equipment	<input type="checkbox"/>	<input type="checkbox"/>	<input type="checkbox"/>	<input type="checkbox"/>	
Function of moving lifting cylinder	<input type="checkbox"/>	<input type="checkbox"/>	<input type="checkbox"/>	<input type="checkbox"/>	
Condition of welding seams	<input type="checkbox"/>	<input type="checkbox"/>	<input type="checkbox"/>	<input type="checkbox"/>	
General lift condition	<input type="checkbox"/>	<input type="checkbox"/>	<input type="checkbox"/>	<input type="checkbox"/>	
Condition of structural components	<input type="checkbox"/>	<input type="checkbox"/>	<input type="checkbox"/>	<input type="checkbox"/>	
Condition of controls	<input type="checkbox"/>	<input type="checkbox"/>	<input type="checkbox"/>	<input type="checkbox"/>	
Condition of control panel	<input type="checkbox"/>	<input type="checkbox"/>	<input type="checkbox"/>	<input type="checkbox"/>	
Check pick-up lift components (distortion, cracks)	<input type="checkbox"/>	<input type="checkbox"/>	<input type="checkbox"/>	<input type="checkbox"/>	
Condition of lifting cylinder	<input type="checkbox"/>	<input type="checkbox"/>	<input type="checkbox"/>	<input type="checkbox"/>	
Test screws torque	<input type="checkbox"/>	<input type="checkbox"/>	<input type="checkbox"/>	<input type="checkbox"/>	
Function of safety mechanisms	<input type="checkbox"/>	<input type="checkbox"/>	<input type="checkbox"/>	<input type="checkbox"/>	
Condition of covers	<input type="checkbox"/>	<input type="checkbox"/>	<input type="checkbox"/>	<input type="checkbox"/>	
Hydraulic system leak-proof	<input type="checkbox"/>	<input type="checkbox"/>	<input type="checkbox"/>	<input type="checkbox"/>	
Fill level of hydraulic tank	<input type="checkbox"/>	<input type="checkbox"/>	<input type="checkbox"/>	<input type="checkbox"/>	
Condition of hydraulic hoses	<input type="checkbox"/>	<input type="checkbox"/>	<input type="checkbox"/>	<input type="checkbox"/>	
Condition of electrical cables	<input type="checkbox"/>	<input type="checkbox"/>	<input type="checkbox"/>	<input type="checkbox"/>	
Function test with lifted vehicle	<input type="checkbox"/>	<input type="checkbox"/>	<input type="checkbox"/>	<input type="checkbox"/>	

Safety check carried out

Date:

Company:

Competent person (name, address)
.....
.....

.....
Signature operator

Result

Further operation inadvisable, re-inspection necessary

Further operation possible, rectify faults

Further operation without objections, lift faultless

.....
Signature competent person

Faults remedied on

Use different form for re-inspection!

.....
Signature operator

.....
Signature competent person

Annual safety check only by competent person

**Keep completed form
in inspection book
(Annex)!**

**Carry out the following test steps.
Tick if appropriate.**

Type

Serial number:

Step-by-step safety check	Ok	Fault	Miss- ing	Check again	Remarks
Short instruction manual	<input type="checkbox"/>	<input type="checkbox"/>	<input type="checkbox"/>	<input type="checkbox"/>	
Type label	<input type="checkbox"/>	<input type="checkbox"/>	<input type="checkbox"/>	<input type="checkbox"/>	
Warning signs	<input type="checkbox"/>	<input type="checkbox"/>	<input type="checkbox"/>	<input type="checkbox"/>	
Function lifting / lowering	<input type="checkbox"/>	<input type="checkbox"/>	<input type="checkbox"/>	<input type="checkbox"/>	
Condition pick-up equipment	<input type="checkbox"/>	<input type="checkbox"/>	<input type="checkbox"/>	<input type="checkbox"/>	
Function moving lifting cylinder	<input type="checkbox"/>	<input type="checkbox"/>	<input type="checkbox"/>	<input type="checkbox"/>	
Condition welding seams	<input type="checkbox"/>	<input type="checkbox"/>	<input type="checkbox"/>	<input type="checkbox"/>	
General lift condition	<input type="checkbox"/>	<input type="checkbox"/>	<input type="checkbox"/>	<input type="checkbox"/>	
Condition structural components	<input type="checkbox"/>	<input type="checkbox"/>	<input type="checkbox"/>	<input type="checkbox"/>	
Condition controls	<input type="checkbox"/>	<input type="checkbox"/>	<input type="checkbox"/>	<input type="checkbox"/>	
Condition control panel	<input type="checkbox"/>	<input type="checkbox"/>	<input type="checkbox"/>	<input type="checkbox"/>	
Check pick-up lift components (distortion, cracks)	<input type="checkbox"/>	<input type="checkbox"/>	<input type="checkbox"/>	<input type="checkbox"/>	
Condition lifting cylinder	<input type="checkbox"/>	<input type="checkbox"/>	<input type="checkbox"/>	<input type="checkbox"/>	
Test screws torque	<input type="checkbox"/>	<input type="checkbox"/>	<input type="checkbox"/>	<input type="checkbox"/>	
Function safety mechanisms	<input type="checkbox"/>	<input type="checkbox"/>	<input type="checkbox"/>	<input type="checkbox"/>	
Condition covers	<input type="checkbox"/>	<input type="checkbox"/>	<input type="checkbox"/>	<input type="checkbox"/>	
Hydraulic system leak-proof	<input type="checkbox"/>	<input type="checkbox"/>	<input type="checkbox"/>	<input type="checkbox"/>	
Fill level hydraulic tank	<input type="checkbox"/>	<input type="checkbox"/>	<input type="checkbox"/>	<input type="checkbox"/>	
Condition hydraulic hoses	<input type="checkbox"/>	<input type="checkbox"/>	<input type="checkbox"/>	<input type="checkbox"/>	
Condition electric cables	<input type="checkbox"/>	<input type="checkbox"/>	<input type="checkbox"/>	<input type="checkbox"/>	
Function test with lifted vehicle	<input type="checkbox"/>	<input type="checkbox"/>	<input type="checkbox"/>	<input type="checkbox"/>	

Safety check carried out

Date:

Company:

Competent person (name, address)
.....

.....
Signature operator

Result

Further operation inadvisable, re-inspection necessary

Further operation possible, rectify faults

Further operation without objections, lift faultless

.....
Signature competent person

Faults remedied on

Use different form for recheck!

.....
Signature operator

.....
Signature competent person

Annual safety check only by competent person

Keep completed in
form in inspection
book (Annex)!

Carry out the following test steps.
Tick if appropriate.

Type

Serial number:

Step-by-step safety check	Ok	Fault	Miss- ing	Check again	Remarks
Short instruction manual	<input type="checkbox"/>	<input type="checkbox"/>	<input type="checkbox"/>	<input type="checkbox"/>	
Type label	<input type="checkbox"/>	<input type="checkbox"/>	<input type="checkbox"/>	<input type="checkbox"/>	
Warning signs	<input type="checkbox"/>	<input type="checkbox"/>	<input type="checkbox"/>	<input type="checkbox"/>	
Function lifting / lowering	<input type="checkbox"/>	<input type="checkbox"/>	<input type="checkbox"/>	<input type="checkbox"/>	
Condition pick-up equipment	<input type="checkbox"/>	<input type="checkbox"/>	<input type="checkbox"/>	<input type="checkbox"/>	
Function moving lifting cylinder	<input type="checkbox"/>	<input type="checkbox"/>	<input type="checkbox"/>	<input type="checkbox"/>	
Condition welding seams	<input type="checkbox"/>	<input type="checkbox"/>	<input type="checkbox"/>	<input type="checkbox"/>	
General lift condition	<input type="checkbox"/>	<input type="checkbox"/>	<input type="checkbox"/>	<input type="checkbox"/>	
Condition structural components	<input type="checkbox"/>	<input type="checkbox"/>	<input type="checkbox"/>	<input type="checkbox"/>	
Condition controls	<input type="checkbox"/>	<input type="checkbox"/>	<input type="checkbox"/>	<input type="checkbox"/>	
Condition control panel	<input type="checkbox"/>	<input type="checkbox"/>	<input type="checkbox"/>	<input type="checkbox"/>	
Check pick-up lift components (distortion, cracks)	<input type="checkbox"/>	<input type="checkbox"/>	<input type="checkbox"/>	<input type="checkbox"/>	
Condition lifting cylinder	<input type="checkbox"/>	<input type="checkbox"/>	<input type="checkbox"/>	<input type="checkbox"/>	
Test screws torque	<input type="checkbox"/>	<input type="checkbox"/>	<input type="checkbox"/>	<input type="checkbox"/>	
Function safety mechanisms	<input type="checkbox"/>	<input type="checkbox"/>	<input type="checkbox"/>	<input type="checkbox"/>	
Condition covers	<input type="checkbox"/>	<input type="checkbox"/>	<input type="checkbox"/>	<input type="checkbox"/>	
Hydraulic system leak-proof	<input type="checkbox"/>	<input type="checkbox"/>	<input type="checkbox"/>	<input type="checkbox"/>	
Fill level hydraulic tank	<input type="checkbox"/>	<input type="checkbox"/>	<input type="checkbox"/>	<input type="checkbox"/>	
Condition hydraulic hoses	<input type="checkbox"/>	<input type="checkbox"/>	<input type="checkbox"/>	<input type="checkbox"/>	
Condition electric cables	<input type="checkbox"/>	<input type="checkbox"/>	<input type="checkbox"/>	<input type="checkbox"/>	
Function test with lifted vehicle	<input type="checkbox"/>	<input type="checkbox"/>	<input type="checkbox"/>	<input type="checkbox"/>	

Safety check carried out

Date:

Company:

Competent person (name, address)
.....

.....
Signature operator

Result

Further operation inadvisable, re-inspection necessary

Further operation possible, rectify faults

Further operation without objections, lift faultless

.....
Signature competent person

Faults remedied on

Use different form for re-inspection!

.....
Signature operator

.....
Signature competent person

Annual safety check only by competent person

**Keep completed form
in inspection book
(Annex)!**

**Carry out the following test steps.
Tick if appropriate.**

Type

Serial number:

Step-by-step safety check	Ok	Fault	Miss- ing	Check again	Remarks
Short instruction manual	<input type="checkbox"/>	<input type="checkbox"/>	<input type="checkbox"/>	<input type="checkbox"/>	
Type label	<input type="checkbox"/>	<input type="checkbox"/>	<input type="checkbox"/>	<input type="checkbox"/>	
Warning signs	<input type="checkbox"/>	<input type="checkbox"/>	<input type="checkbox"/>	<input type="checkbox"/>	
Function lifting / lowering	<input type="checkbox"/>	<input type="checkbox"/>	<input type="checkbox"/>	<input type="checkbox"/>	
Condition pick-up equipment	<input type="checkbox"/>	<input type="checkbox"/>	<input type="checkbox"/>	<input type="checkbox"/>	
Function moving lifting cylinder	<input type="checkbox"/>	<input type="checkbox"/>	<input type="checkbox"/>	<input type="checkbox"/>	
Condition welding seams	<input type="checkbox"/>	<input type="checkbox"/>	<input type="checkbox"/>	<input type="checkbox"/>	
General lift condition	<input type="checkbox"/>	<input type="checkbox"/>	<input type="checkbox"/>	<input type="checkbox"/>	
Condition structural components	<input type="checkbox"/>	<input type="checkbox"/>	<input type="checkbox"/>	<input type="checkbox"/>	
Condition controls	<input type="checkbox"/>	<input type="checkbox"/>	<input type="checkbox"/>	<input type="checkbox"/>	
Condition control panel	<input type="checkbox"/>	<input type="checkbox"/>	<input type="checkbox"/>	<input type="checkbox"/>	
Check pick-up lift components (distortion, cracks)	<input type="checkbox"/>	<input type="checkbox"/>	<input type="checkbox"/>	<input type="checkbox"/>	
Condition lifting cylinder	<input type="checkbox"/>	<input type="checkbox"/>	<input type="checkbox"/>	<input type="checkbox"/>	
Test screws torque	<input type="checkbox"/>	<input type="checkbox"/>	<input type="checkbox"/>	<input type="checkbox"/>	
Function safety mechanisms	<input type="checkbox"/>	<input type="checkbox"/>	<input type="checkbox"/>	<input type="checkbox"/>	
Condition covers	<input type="checkbox"/>	<input type="checkbox"/>	<input type="checkbox"/>	<input type="checkbox"/>	
Hydraulic system leak-proof	<input type="checkbox"/>	<input type="checkbox"/>	<input type="checkbox"/>	<input type="checkbox"/>	
Fill level hydraulic tank	<input type="checkbox"/>	<input type="checkbox"/>	<input type="checkbox"/>	<input type="checkbox"/>	
Condition hydraulic hoses	<input type="checkbox"/>	<input type="checkbox"/>	<input type="checkbox"/>	<input type="checkbox"/>	
Condition electric cables	<input type="checkbox"/>	<input type="checkbox"/>	<input type="checkbox"/>	<input type="checkbox"/>	
Function test with lifted vehicle	<input type="checkbox"/>	<input type="checkbox"/>	<input type="checkbox"/>	<input type="checkbox"/>	

Safety check carried out

Date:

Company:

Competent person (name, address)
.....

.....
Signature operator

Result

Further operation inadvisable, re-inspection necessary

Further operation possible, rectify faults

Further operation without objections, lift faultless

.....
Signature competent person

Faults remedied on

Use different form for re-inspection!

.....
Signature operator

.....
Signature competent person

Annual safety check only by competent person

Keep completed form
in inspection book
(Annex)!

Carry out the following test steps.
Tick if appropriate.

Type

Serial number:

Step-by-step safety check	Ok	Fault	Miss- ing	Check again	Remarks
Short instruction manual	<input type="checkbox"/>	<input type="checkbox"/>	<input type="checkbox"/>	<input type="checkbox"/>	
Type label	<input type="checkbox"/>	<input type="checkbox"/>	<input type="checkbox"/>	<input type="checkbox"/>	
Warning signs	<input type="checkbox"/>	<input type="checkbox"/>	<input type="checkbox"/>	<input type="checkbox"/>	
Function lifting / lowering	<input type="checkbox"/>	<input type="checkbox"/>	<input type="checkbox"/>	<input type="checkbox"/>	
Condition pick-up equipment	<input type="checkbox"/>	<input type="checkbox"/>	<input type="checkbox"/>	<input type="checkbox"/>	
Function moving lifting cylinder	<input type="checkbox"/>	<input type="checkbox"/>	<input type="checkbox"/>	<input type="checkbox"/>	
Condition welding seams	<input type="checkbox"/>	<input type="checkbox"/>	<input type="checkbox"/>	<input type="checkbox"/>	
General lift condition	<input type="checkbox"/>	<input type="checkbox"/>	<input type="checkbox"/>	<input type="checkbox"/>	
Condition structural components	<input type="checkbox"/>	<input type="checkbox"/>	<input type="checkbox"/>	<input type="checkbox"/>	
Condition controls	<input type="checkbox"/>	<input type="checkbox"/>	<input type="checkbox"/>	<input type="checkbox"/>	
Condition control panel	<input type="checkbox"/>	<input type="checkbox"/>	<input type="checkbox"/>	<input type="checkbox"/>	
Check pick-up lift components (distortion, cracks)	<input type="checkbox"/>	<input type="checkbox"/>	<input type="checkbox"/>	<input type="checkbox"/>	
Condition lifting cylinder	<input type="checkbox"/>	<input type="checkbox"/>	<input type="checkbox"/>	<input type="checkbox"/>	
Test screws torque	<input type="checkbox"/>	<input type="checkbox"/>	<input type="checkbox"/>	<input type="checkbox"/>	
Function safety mechanisms	<input type="checkbox"/>	<input type="checkbox"/>	<input type="checkbox"/>	<input type="checkbox"/>	
Condition covers	<input type="checkbox"/>	<input type="checkbox"/>	<input type="checkbox"/>	<input type="checkbox"/>	
Hydraulic system leak-proof	<input type="checkbox"/>	<input type="checkbox"/>	<input type="checkbox"/>	<input type="checkbox"/>	
Fill level hydraulic tank	<input type="checkbox"/>	<input type="checkbox"/>	<input type="checkbox"/>	<input type="checkbox"/>	
Condition hydraulic hoses	<input type="checkbox"/>	<input type="checkbox"/>	<input type="checkbox"/>	<input type="checkbox"/>	
Condition electric cables	<input type="checkbox"/>	<input type="checkbox"/>	<input type="checkbox"/>	<input type="checkbox"/>	
Function test with lifted vehicle	<input type="checkbox"/>	<input type="checkbox"/>	<input type="checkbox"/>	<input type="checkbox"/>	

Safety check carried out

Date:

Company:

Competent person (name, address)
.....

.....
Signature operator

Result

Further operation inadvisable, re-inspection necessary

Further operation possible, rectify faults

Further operation without objections, lift faultless

.....
Signature competent person

Faults remedied on

Use different form for re-inspection!

.....
Signature operator

.....
Signature competent person

Annual safety check only by competent person

**Keep completed form
in inspection book
(Annex)!**

**Carry out the following test steps.
Tick if appropriate.**

Type

Serial number:

Step-by-step safety check	Ok	Fault	Miss- ing	Check again	Remarks
Short instruction manual	<input type="checkbox"/>	<input type="checkbox"/>	<input type="checkbox"/>	<input type="checkbox"/>	
Type label	<input type="checkbox"/>	<input type="checkbox"/>	<input type="checkbox"/>	<input type="checkbox"/>	
Warning signs	<input type="checkbox"/>	<input type="checkbox"/>	<input type="checkbox"/>	<input type="checkbox"/>	
Function lifting / lowering	<input type="checkbox"/>	<input type="checkbox"/>	<input type="checkbox"/>	<input type="checkbox"/>	
Condition pick-up equipment	<input type="checkbox"/>	<input type="checkbox"/>	<input type="checkbox"/>	<input type="checkbox"/>	
Function moving lifting cylinder	<input type="checkbox"/>	<input type="checkbox"/>	<input type="checkbox"/>	<input type="checkbox"/>	
Condition welding seams	<input type="checkbox"/>	<input type="checkbox"/>	<input type="checkbox"/>	<input type="checkbox"/>	
General lift condition	<input type="checkbox"/>	<input type="checkbox"/>	<input type="checkbox"/>	<input type="checkbox"/>	
Condition structural components	<input type="checkbox"/>	<input type="checkbox"/>	<input type="checkbox"/>	<input type="checkbox"/>	
Condition controls	<input type="checkbox"/>	<input type="checkbox"/>	<input type="checkbox"/>	<input type="checkbox"/>	
Condition control panel	<input type="checkbox"/>	<input type="checkbox"/>	<input type="checkbox"/>	<input type="checkbox"/>	
Check pick-up lift components (distortion, cracks)	<input type="checkbox"/>	<input type="checkbox"/>	<input type="checkbox"/>	<input type="checkbox"/>	
Condition lifting cylinder	<input type="checkbox"/>	<input type="checkbox"/>	<input type="checkbox"/>	<input type="checkbox"/>	
Test screws torque	<input type="checkbox"/>	<input type="checkbox"/>	<input type="checkbox"/>	<input type="checkbox"/>	
Function safety mechanisms	<input type="checkbox"/>	<input type="checkbox"/>	<input type="checkbox"/>	<input type="checkbox"/>	
Condition covers	<input type="checkbox"/>	<input type="checkbox"/>	<input type="checkbox"/>	<input type="checkbox"/>	
Hydraulic system leak-proof	<input type="checkbox"/>	<input type="checkbox"/>	<input type="checkbox"/>	<input type="checkbox"/>	
Fill level hydraulic tank	<input type="checkbox"/>	<input type="checkbox"/>	<input type="checkbox"/>	<input type="checkbox"/>	
Condition hydraulic hoses	<input type="checkbox"/>	<input type="checkbox"/>	<input type="checkbox"/>	<input type="checkbox"/>	
Condition electric cables	<input type="checkbox"/>	<input type="checkbox"/>	<input type="checkbox"/>	<input type="checkbox"/>	
Function test with lifted vehicle	<input type="checkbox"/>	<input type="checkbox"/>	<input type="checkbox"/>	<input type="checkbox"/>	

Safety check carried out

Date:

Company:

Competent person (name, address)
.....

.....
Signature operator

Result

Further operation inadvisable, re-inspection necessary

Further operation possible, rectify faults

Further operation without objections, lift faultless

.....
Signature competent person

Faults remedied on

Use different form for re-inspection!

.....
Signature operator

.....
Signature competent person

Annual safety check only by competent person

Keep completed form
in inspection book
(Annex)!

Carry out the following test steps.
Tick if appropriate.

Type

Serial number:

Step-by-step safety check	Ok	Fault	Miss- ing	Check again	Remarks
Short instruction manual	<input type="checkbox"/>	<input type="checkbox"/>	<input type="checkbox"/>	<input type="checkbox"/>	
Type label	<input type="checkbox"/>	<input type="checkbox"/>	<input type="checkbox"/>	<input type="checkbox"/>	
Warning signs	<input type="checkbox"/>	<input type="checkbox"/>	<input type="checkbox"/>	<input type="checkbox"/>	
Function lifting / lowering	<input type="checkbox"/>	<input type="checkbox"/>	<input type="checkbox"/>	<input type="checkbox"/>	
Condition pick-up equipment	<input type="checkbox"/>	<input type="checkbox"/>	<input type="checkbox"/>	<input type="checkbox"/>	
Function moving lifting cylinder	<input type="checkbox"/>	<input type="checkbox"/>	<input type="checkbox"/>	<input type="checkbox"/>	
Condition welding seams	<input type="checkbox"/>	<input type="checkbox"/>	<input type="checkbox"/>	<input type="checkbox"/>	
General lift condition	<input type="checkbox"/>	<input type="checkbox"/>	<input type="checkbox"/>	<input type="checkbox"/>	
Condition structural components	<input type="checkbox"/>	<input type="checkbox"/>	<input type="checkbox"/>	<input type="checkbox"/>	
Condition controls	<input type="checkbox"/>	<input type="checkbox"/>	<input type="checkbox"/>	<input type="checkbox"/>	
Condition control panel	<input type="checkbox"/>	<input type="checkbox"/>	<input type="checkbox"/>	<input type="checkbox"/>	
Check pick-up lift components (distortion, cracks)	<input type="checkbox"/>	<input type="checkbox"/>	<input type="checkbox"/>	<input type="checkbox"/>	
Condition lifting cylinder	<input type="checkbox"/>	<input type="checkbox"/>	<input type="checkbox"/>	<input type="checkbox"/>	
Test screws torque	<input type="checkbox"/>	<input type="checkbox"/>	<input type="checkbox"/>	<input type="checkbox"/>	
Function safety mechanisms	<input type="checkbox"/>	<input type="checkbox"/>	<input type="checkbox"/>	<input type="checkbox"/>	
Condition covers	<input type="checkbox"/>	<input type="checkbox"/>	<input type="checkbox"/>	<input type="checkbox"/>	
Hydraulic system leak-proof	<input type="checkbox"/>	<input type="checkbox"/>	<input type="checkbox"/>	<input type="checkbox"/>	
Fill level hydraulic tank	<input type="checkbox"/>	<input type="checkbox"/>	<input type="checkbox"/>	<input type="checkbox"/>	
Condition hydraulic hoses	<input type="checkbox"/>	<input type="checkbox"/>	<input type="checkbox"/>	<input type="checkbox"/>	
Condition electric cables	<input type="checkbox"/>	<input type="checkbox"/>	<input type="checkbox"/>	<input type="checkbox"/>	
Function test with lifted vehicle	<input type="checkbox"/>	<input type="checkbox"/>	<input type="checkbox"/>	<input type="checkbox"/>	

Safety check carried out

Date:

Company:

Competent person (name, address)
.....
.....

.....
Signature operator

Result

Further operation inadvisable, re-inspection necessary

Further operation possible, rectify faults

Further operation without objections, lift faultless

.....
Signature competent person

Faults remedied on

Use different form for re-inspection!

.....
Signature operator

.....
Signature competent person

Annual safety check only by competent person

**Keep completed form
in inspection book
(Annex)!**

**Carry out the following test steps.
Tick if appropriate.**

Type

Serial number:

Step-by-step safety check	Ok	Fault	Miss- ing	Check again	Remarks
Short instruction manual	<input type="checkbox"/>	<input type="checkbox"/>	<input type="checkbox"/>	<input type="checkbox"/>	
Type label	<input type="checkbox"/>	<input type="checkbox"/>	<input type="checkbox"/>	<input type="checkbox"/>	
Warning signs	<input type="checkbox"/>	<input type="checkbox"/>	<input type="checkbox"/>	<input type="checkbox"/>	
Function lifting / lowering	<input type="checkbox"/>	<input type="checkbox"/>	<input type="checkbox"/>	<input type="checkbox"/>	
Condition pick-up equipment	<input type="checkbox"/>	<input type="checkbox"/>	<input type="checkbox"/>	<input type="checkbox"/>	
Function moving lifting cylinder	<input type="checkbox"/>	<input type="checkbox"/>	<input type="checkbox"/>	<input type="checkbox"/>	
Condition welding seams	<input type="checkbox"/>	<input type="checkbox"/>	<input type="checkbox"/>	<input type="checkbox"/>	
General lift condition	<input type="checkbox"/>	<input type="checkbox"/>	<input type="checkbox"/>	<input type="checkbox"/>	
Condition structural components	<input type="checkbox"/>	<input type="checkbox"/>	<input type="checkbox"/>	<input type="checkbox"/>	
Condition controls	<input type="checkbox"/>	<input type="checkbox"/>	<input type="checkbox"/>	<input type="checkbox"/>	
Condition control panel	<input type="checkbox"/>	<input type="checkbox"/>	<input type="checkbox"/>	<input type="checkbox"/>	
Check pick-up lift components (distortion, cracks)	<input type="checkbox"/>	<input type="checkbox"/>	<input type="checkbox"/>	<input type="checkbox"/>	
Condition lifting cylinder	<input type="checkbox"/>	<input type="checkbox"/>	<input type="checkbox"/>	<input type="checkbox"/>	
Test screws torque	<input type="checkbox"/>	<input type="checkbox"/>	<input type="checkbox"/>	<input type="checkbox"/>	
Function safety mechanisms	<input type="checkbox"/>	<input type="checkbox"/>	<input type="checkbox"/>	<input type="checkbox"/>	
Condition covers	<input type="checkbox"/>	<input type="checkbox"/>	<input type="checkbox"/>	<input type="checkbox"/>	
Hydraulic system leak-proof	<input type="checkbox"/>	<input type="checkbox"/>	<input type="checkbox"/>	<input type="checkbox"/>	
Fill level hydraulic tank	<input type="checkbox"/>	<input type="checkbox"/>	<input type="checkbox"/>	<input type="checkbox"/>	
Condition hydraulic hoses	<input type="checkbox"/>	<input type="checkbox"/>	<input type="checkbox"/>	<input type="checkbox"/>	
Condition electric cables	<input type="checkbox"/>	<input type="checkbox"/>	<input type="checkbox"/>	<input type="checkbox"/>	
Function test with lifted vehicle	<input type="checkbox"/>	<input type="checkbox"/>	<input type="checkbox"/>	<input type="checkbox"/>	

Safety check carried out

Date:

Company:

Competent person (name, address)
.....

.....
Signature operator

Result

Further operation inadvisable, re-inspection necessary

Further operation possible, rectify faults

Further operation without objections, lift faultless

.....
Signature competent person

Faults remedied on

Use different form for re-inspection!

.....
Signature operator

.....
Signature competent person

Annual safety check only by competent person

**Keep completed form
in inspection book
(Annex)!**

Carry out the following test steps.
Tick if appropriate.

Type

Serial number:

Step-by-step safety check	Ok	Fault	Miss- ing	Check again	Remarks
Short instruction manual	<input type="checkbox"/>	<input type="checkbox"/>	<input type="checkbox"/>	<input type="checkbox"/>	
Type label	<input type="checkbox"/>	<input type="checkbox"/>	<input type="checkbox"/>	<input type="checkbox"/>	
Warning signs	<input type="checkbox"/>	<input type="checkbox"/>	<input type="checkbox"/>	<input type="checkbox"/>	
Function lifting / lowering	<input type="checkbox"/>	<input type="checkbox"/>	<input type="checkbox"/>	<input type="checkbox"/>	
Condition pick-up equipment	<input type="checkbox"/>	<input type="checkbox"/>	<input type="checkbox"/>	<input type="checkbox"/>	
Function moving lifting cylinder	<input type="checkbox"/>	<input type="checkbox"/>	<input type="checkbox"/>	<input type="checkbox"/>	
Condition welding seams	<input type="checkbox"/>	<input type="checkbox"/>	<input type="checkbox"/>	<input type="checkbox"/>	
General lift condition	<input type="checkbox"/>	<input type="checkbox"/>	<input type="checkbox"/>	<input type="checkbox"/>	
Condition structural components	<input type="checkbox"/>	<input type="checkbox"/>	<input type="checkbox"/>	<input type="checkbox"/>	
Condition controls	<input type="checkbox"/>	<input type="checkbox"/>	<input type="checkbox"/>	<input type="checkbox"/>	
Condition control panel	<input type="checkbox"/>	<input type="checkbox"/>	<input type="checkbox"/>	<input type="checkbox"/>	
Check pick-up lift components (distortion, cracks)	<input type="checkbox"/>	<input type="checkbox"/>	<input type="checkbox"/>	<input type="checkbox"/>	
Condition lifting cylinder	<input type="checkbox"/>	<input type="checkbox"/>	<input type="checkbox"/>	<input type="checkbox"/>	
Test screws torque	<input type="checkbox"/>	<input type="checkbox"/>	<input type="checkbox"/>	<input type="checkbox"/>	
Function safety mechanisms	<input type="checkbox"/>	<input type="checkbox"/>	<input type="checkbox"/>	<input type="checkbox"/>	
Condition covers	<input type="checkbox"/>	<input type="checkbox"/>	<input type="checkbox"/>	<input type="checkbox"/>	
Hydraulic system leak-proof	<input type="checkbox"/>	<input type="checkbox"/>	<input type="checkbox"/>	<input type="checkbox"/>	
Fill level hydraulic tank	<input type="checkbox"/>	<input type="checkbox"/>	<input type="checkbox"/>	<input type="checkbox"/>	
Condition hydraulic hoses	<input type="checkbox"/>	<input type="checkbox"/>	<input type="checkbox"/>	<input type="checkbox"/>	
Condition electric cables	<input type="checkbox"/>	<input type="checkbox"/>	<input type="checkbox"/>	<input type="checkbox"/>	
Function test with lifted vehicle	<input type="checkbox"/>	<input type="checkbox"/>	<input type="checkbox"/>	<input type="checkbox"/>	

Safety check carried out

Date:

Company:

Competent person (name, address)
.....
.....

.....
Signature operator

Result

Further operation inadvisable, re-inspection necessary

Further operation possible, rectify faults

Further operation without objections, lift faultless

.....
Signature competent person

Faults remedied on

Use different form for re-inspection!

.....
Signature operator

.....
Signature competent person

Special safety check only by competent person

**Keep completed form
in inspection book
(Annex)!**

**Carry out the following test steps.
Tick if appropriate.**

Type

Serial number:

Step-by-step safety check	Ok	Fault	Miss- ing	Check again	Remarks
Short instruction manual	<input type="checkbox"/>	<input type="checkbox"/>	<input type="checkbox"/>	<input type="checkbox"/>	
Type label	<input type="checkbox"/>	<input type="checkbox"/>	<input type="checkbox"/>	<input type="checkbox"/>	
Warning signs	<input type="checkbox"/>	<input type="checkbox"/>	<input type="checkbox"/>	<input type="checkbox"/>	
Function lifting / lowering	<input type="checkbox"/>	<input type="checkbox"/>	<input type="checkbox"/>	<input type="checkbox"/>	
Condition pick-up equipment	<input type="checkbox"/>	<input type="checkbox"/>	<input type="checkbox"/>	<input type="checkbox"/>	
Function moving lifting cylinder	<input type="checkbox"/>	<input type="checkbox"/>	<input type="checkbox"/>	<input type="checkbox"/>	
Condition welding seams	<input type="checkbox"/>	<input type="checkbox"/>	<input type="checkbox"/>	<input type="checkbox"/>	
General lift condition	<input type="checkbox"/>	<input type="checkbox"/>	<input type="checkbox"/>	<input type="checkbox"/>	
Condition structural components	<input type="checkbox"/>	<input type="checkbox"/>	<input type="checkbox"/>	<input type="checkbox"/>	
Condition controls	<input type="checkbox"/>	<input type="checkbox"/>	<input type="checkbox"/>	<input type="checkbox"/>	
Condition control panel	<input type="checkbox"/>	<input type="checkbox"/>	<input type="checkbox"/>	<input type="checkbox"/>	
Check pick-up lift components (distortion, cracks)	<input type="checkbox"/>	<input type="checkbox"/>	<input type="checkbox"/>	<input type="checkbox"/>	
Condition lifting cylinder	<input type="checkbox"/>	<input type="checkbox"/>	<input type="checkbox"/>	<input type="checkbox"/>	
Test screws torque	<input type="checkbox"/>	<input type="checkbox"/>	<input type="checkbox"/>	<input type="checkbox"/>	
Function safety mechanisms	<input type="checkbox"/>	<input type="checkbox"/>	<input type="checkbox"/>	<input type="checkbox"/>	
Condition covers	<input type="checkbox"/>	<input type="checkbox"/>	<input type="checkbox"/>	<input type="checkbox"/>	
Hydraulic system leak-proof	<input type="checkbox"/>	<input type="checkbox"/>	<input type="checkbox"/>	<input type="checkbox"/>	
Fill level hydraulic tank	<input type="checkbox"/>	<input type="checkbox"/>	<input type="checkbox"/>	<input type="checkbox"/>	
Condition hydraulic hoses	<input type="checkbox"/>	<input type="checkbox"/>	<input type="checkbox"/>	<input type="checkbox"/>	
Condition electric cables	<input type="checkbox"/>	<input type="checkbox"/>	<input type="checkbox"/>	<input type="checkbox"/>	
Function test with lifted vehicle	<input type="checkbox"/>	<input type="checkbox"/>	<input type="checkbox"/>	<input type="checkbox"/>	

Safety check carried out

Result

Date:

Further operation inadvisable, re-inspection necessary

Company:

Further operation possible, rectify faults

Competent person (name, address)

Further operation without objections, lift faultless

.....

.....
Signature operator

.....
Signature competent person

Faults remedied on

Use different form for re-inspection!

.....
Signature operator

.....
Signature competent person

INSPECTION BOOK DUPLEX-S2

Date	Maintenance report			carried out by
	monthly	annually	biannually	
	<input type="checkbox"/>	<input type="checkbox"/>	<input type="checkbox"/>	
	<input type="checkbox"/>	<input type="checkbox"/>	<input type="checkbox"/>	
	<input type="checkbox"/>	<input type="checkbox"/>	<input type="checkbox"/>	
	<input type="checkbox"/>	<input type="checkbox"/>	<input type="checkbox"/>	
	<input type="checkbox"/>	<input type="checkbox"/>	<input type="checkbox"/>	
	<input type="checkbox"/>	<input type="checkbox"/>	<input type="checkbox"/>	
	<input type="checkbox"/>	<input type="checkbox"/>	<input type="checkbox"/>	
	<input type="checkbox"/>	<input type="checkbox"/>	<input type="checkbox"/>	
	<input type="checkbox"/>	<input type="checkbox"/>	<input type="checkbox"/>	
	<input type="checkbox"/>	<input type="checkbox"/>	<input type="checkbox"/>	
	<input type="checkbox"/>	<input type="checkbox"/>	<input type="checkbox"/>	
	<input type="checkbox"/>	<input type="checkbox"/>	<input type="checkbox"/>	
	<input type="checkbox"/>	<input type="checkbox"/>	<input type="checkbox"/>	
	<input type="checkbox"/>	<input type="checkbox"/>	<input type="checkbox"/>	
	<input type="checkbox"/>	<input type="checkbox"/>	<input type="checkbox"/>	
	<input type="checkbox"/>	<input type="checkbox"/>	<input type="checkbox"/>	
	<input type="checkbox"/>	<input type="checkbox"/>	<input type="checkbox"/>	
	<input type="checkbox"/>	<input type="checkbox"/>	<input type="checkbox"/>	
	<input type="checkbox"/>	<input type="checkbox"/>	<input type="checkbox"/>	
	<input type="checkbox"/>	<input type="checkbox"/>	<input type="checkbox"/>	
	<input type="checkbox"/>	<input type="checkbox"/>	<input type="checkbox"/>	
	<input type="checkbox"/>	<input type="checkbox"/>	<input type="checkbox"/>	
	<input type="checkbox"/>	<input type="checkbox"/>	<input type="checkbox"/>	
	<input type="checkbox"/>	<input type="checkbox"/>	<input type="checkbox"/>	
	<input type="checkbox"/>	<input type="checkbox"/>	<input type="checkbox"/>	
	<input type="checkbox"/>	<input type="checkbox"/>	<input type="checkbox"/>	
	<input type="checkbox"/>	<input type="checkbox"/>	<input type="checkbox"/>	
	<input type="checkbox"/>	<input type="checkbox"/>	<input type="checkbox"/>	
	<input type="checkbox"/>	<input type="checkbox"/>	<input type="checkbox"/>	
	<input type="checkbox"/>	<input type="checkbox"/>	<input type="checkbox"/>	
	<input type="checkbox"/>	<input type="checkbox"/>	<input type="checkbox"/>	
	<input type="checkbox"/>	<input type="checkbox"/>	<input type="checkbox"/>	
	<input type="checkbox"/>	<input type="checkbox"/>	<input type="checkbox"/>	
	<input type="checkbox"/>	<input type="checkbox"/>	<input type="checkbox"/>	
	<input type="checkbox"/>	<input type="checkbox"/>	<input type="checkbox"/>	
	<input type="checkbox"/>	<input type="checkbox"/>	<input type="checkbox"/>	
	<input type="checkbox"/>	<input type="checkbox"/>	<input type="checkbox"/>	
	<input type="checkbox"/>	<input type="checkbox"/>	<input type="checkbox"/>	
	<input type="checkbox"/>	<input type="checkbox"/>	<input type="checkbox"/>	
	<input type="checkbox"/>	<input type="checkbox"/>	<input type="checkbox"/>	
	<input type="checkbox"/>	<input type="checkbox"/>	<input type="checkbox"/>	

Hydraulics diagram

- SZ Safety cylinder
- 1V1 Lowering brake valve1
- 1V4 Solenoid valve
- 1V5 Solenoid valve
- 1S2 Pressure sensor
- 1V2 Pressure relief valve
- 2 Suction valve
- 1P Geared pump
- 1M Electric motor 3kw
- 1S1 Level sensor
- 1Z1 Intake filter
- 6 Emergency relief valve
- 7 Emergency relief valve
- M, MA G1/4"
- A, P, T G1/2"

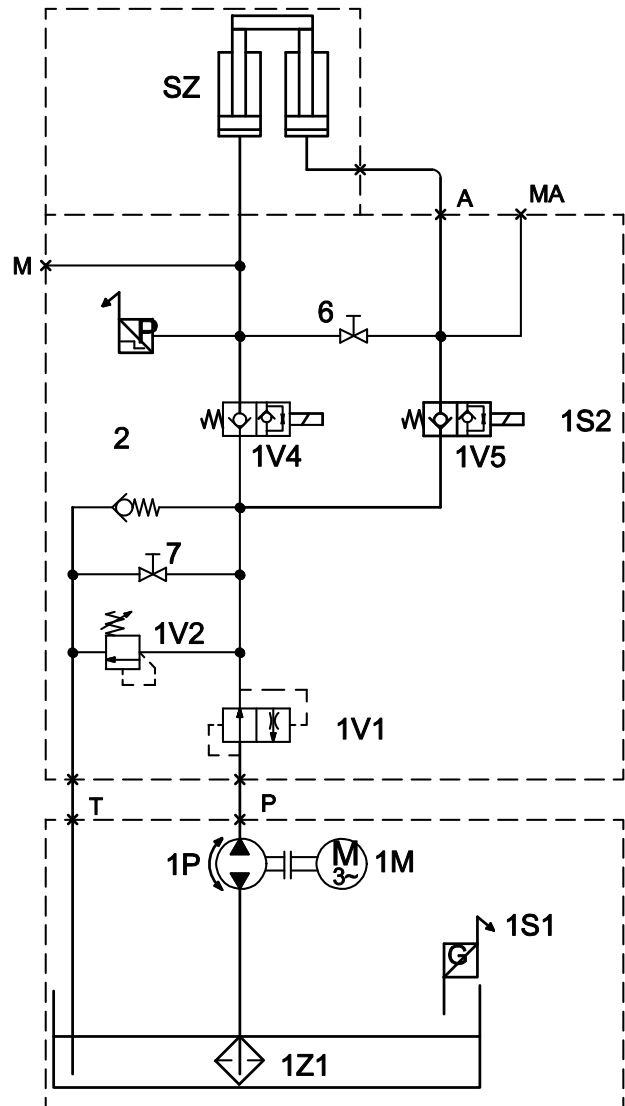



BlitzRotary GmbH

Hüfinger Straße 55
D-78199 Bräunlingen
Phone +49.771.9233.0
Fax +49.771.9233.99
info@blitzrotary.com
www.blitzrotary.com

A  **DOVER** COMPANY

