



SPOA30/SPOA40/SPO40/SPO54 E And M Series

(600 Series)

Two Post Surface Mounted Lifts

SPOA30 Series Capacity: 3,100kg (775 kg per arm)

SPOA40 Series Capacity: 4,000kg (1,000kg per arm)

SPO40 Series Capacity: 4,000kg (1,000kg per arm)

SPO54 Series Capacity: 5,400kg (1350kg per arm)



TÜV
Rheinland

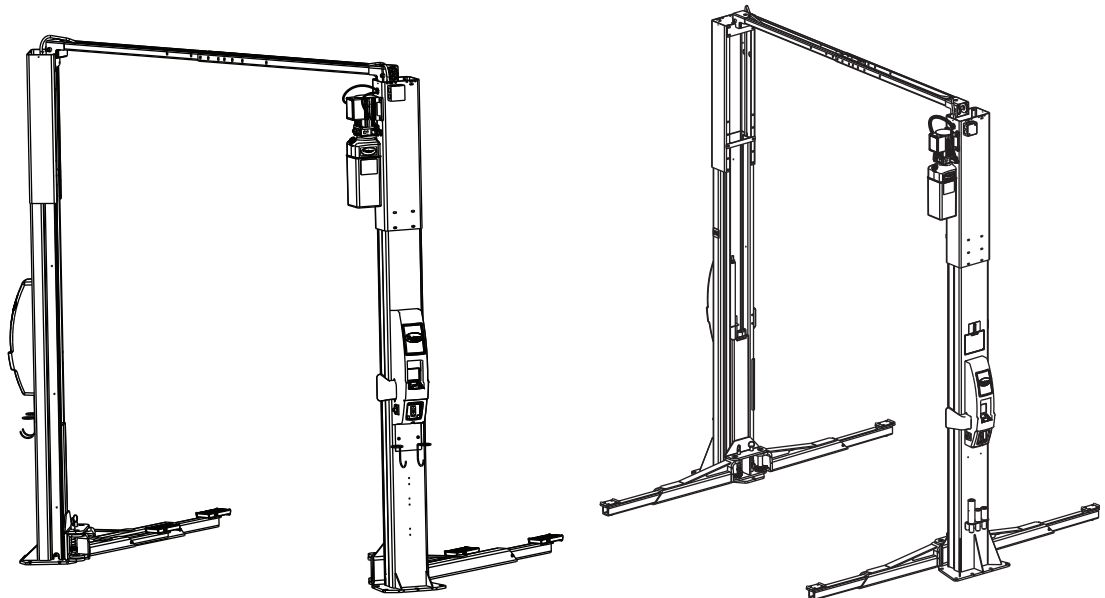

Table of Contents

Safety Instructions	2
Lift Controls	3-4
Operating Instructions	5-7
Inspection and Maintenance for Operators.....	8
Trouble Shooting for Operators	8-9
Trouble Shooting for Qualified Service Representative	10-11
Equalizer and Latch Cable Adjustment	12-13
Manual Lowering Instructions	14
Declaration of Conformity	15

INSTALLER: Please return this booklet to literature package and give to lift owner/operator.

Only those technicians who have been properly trained in the usage and care of the lift should be allowed to operate the lift.

Local regulations MAY require that the trained operator be at least 18 years of age or be supervised by a trained operator while:

- A. Positioning the vehicle in the service bay
- B. Positioning the lift adapters at the vehicle manufacturer's recommended lift points
- C. Actuating the lift controls

Display this manual in a conspicuous location in the lift area convenient to the operator.

The lift is to be used for raising unoccupied motor vehicles **ONLY!**

ALWAYS lift the vehicle using all four (4) adapters.

NEVER raise just one end, one corner, or one side of the vehicle.

ONLY lift vehicles which have an individual axle weight that does not exceed one-half the lift capacity. See load capacity table below.

MODEL	LOAD CAPACITY
SPOA30 Series Lifts	3100kg
SPOA40 Series Lifts	4000kg
SPO40 Series Lifts	4000kg
SPO54 Series Lifts	5400kg

LIFT CONTROLS M SERIES LIFTS

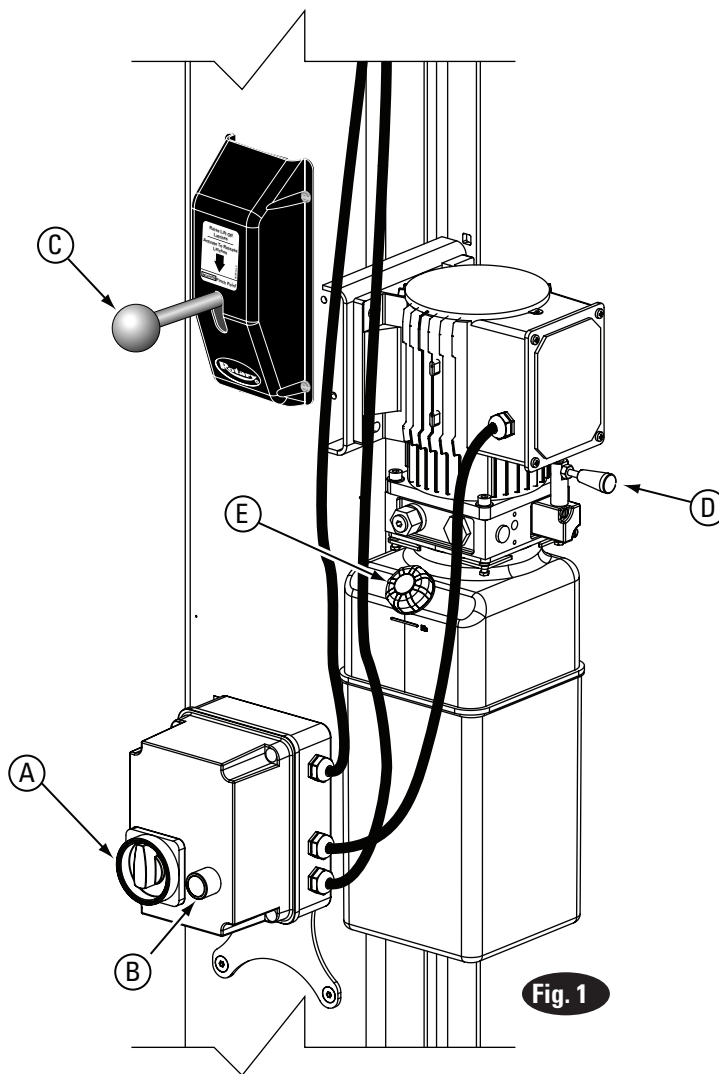

Fig. 1

Fig. 1 Detail	
A	E-Stop Switch
B	Raise Switch
C	Safety Latch Release
D	Lowering Valve Handle
E	Fill-Breather Cap

LIFT CONTROLS E SERIES LIFTS

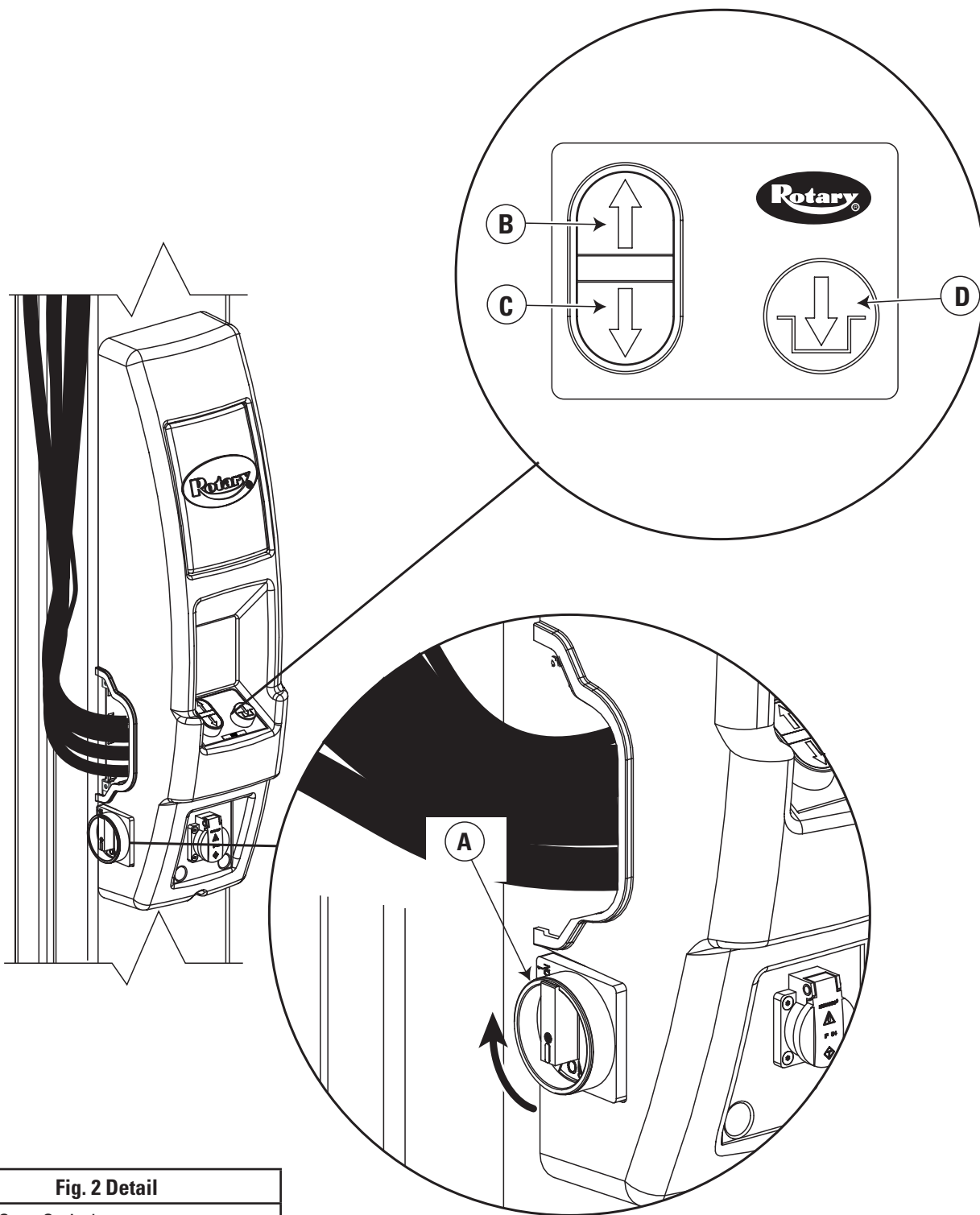

Fig. 2 Detail

A	E-Stop Switch
B	Raises Lift
C	Lowers Lift
D	Lowers Lift To Locking Latches

OPERATING INSTRUCTIONS

SURFACE MOUNTED FRAME ENGAGING LIFTS

⚠️ WARNING To avoid personal injury and/or property damage, permit only trained personnel to operate lift. After reviewing these instructions, get familiar with lift controls by running the lift through a few cycles before loading vehicle on lift.

IMPORTANT Always lift the vehicle using all four adapters. **NEVER** raise just one end, one corner, or one side of vehicle.

Assure vehicle frame can support it's weight & overhead bar or sensor will contact highest point on the vehicle.

1. Before Loading:

- Inspect Lift - See "Operator Inspection And Maintenance" on page 8. Never operate if lift malfunctions or has broken or damaged parts.
- Lift must be fully lowered and service bay clear of all personnel before the vehicle is positioned onto lift.
- Swing arms out to full drive-thru position.
- Assure area around lift is free of tools, debris, grease, and oil.
- Assure Adapter Pads are free from grease and oil.
- **Do Not** allow unauthorized persons in shop area while lift is in use.
- **Do Not** use any part of the lift as a crane or as a support for another lifting mechanism (i.e.: block & tackle, etc.).
- Turn E-Stop switch to "ON" Position, Fig. 1.
For E series lifts turn both E-Stop switches "ON", Fig. 2.

2. Loading:

- **Do Not** allow unauthorized or untrained persons to position vehicle or operate lift.
- **Do Not** drive over arms.
- **Do Not** overload lift. See capacity label on lift.
- Use Only adapter extenders provided by the manufacturer. **Do Not** use wood, concrete blocks, or other improvised extenders.
- Spot vehicle over lift with left front wheel in proper spotting dish position, Fig. 3. Position vehicle according to the center of gravity, not for door opening clearance.
- Check the condition of the pickup points of the vehicle.

- Swing arms under vehicle and position adapters at vehicle manufacturer's recommended lift points, Fig. 4. Adjust adapters to the required height to keep the vehicle level and properly balanced.
- Use optional adapters for under body clearance when required.
- On SP054 Series Lifts adapters are supplied in 102mm and 204mm increments. Stack-up height should not exceed 306mm. No adapters are supplied with special SP054 Sprinter Lift.
- Use adapter extension combination to keep lift as level as possible.

3. To Raise Lift:

- **Do Not** permit anyone on lift or inside vehicle when it is being raised or lowered.
- Maintain visual contact with arms, pickup points, & vehicle throughout the motion of the lift while remaining clear of lift.
- For M Series Lifts: Actuate RAISE Switch on Control Box to raise lift, Fig. 1.
- For E Series Lifts: Push  on control panel, Fig. 2.

Note: Allow 2 seconds between motor starts. Failure to comply may cause motor burnout.

- Stop before making contact with vehicle. Check arm restraint pins for engagement. If required, slightly move arm to allow restraint gear and pawl to mesh. **DO NOT** hammer pin down as this will damage the restraint gear teeth.

- Raise vehicle until tires clear the floor.
- Stop and check adapters for secure contact at vehicle manufacturer's recommended lift points.
- Continue to raise to desired height only if vehicle is stable on lift.
- Lower lift onto safety latches after desired height is reached. (Lift is to be raised high enough for locking latches to engage.)
- For M Series Lifts: Actuate LOWERING VALVE handle to lower lift onto locking latches.
- For E Series Lifts: Actuate  control panel to lower lift onto locking latches.
- **DO NOT** go under vehicle if all four adapters are not in stable contact at vehicle manufacturer's recommended lift points.
- Repeat complete spotting, loading, and raising procedures if vehicle is unstable.

4. While Using Lift:

- Avoid excessive rocking of vehicle while on lift.
- Always use safety stands as needed for stability when removing or installing heavy components. (i.e.: engines, transmissions, etc.) Use 4 safety stands.
- Raise safety stands to meet vehicle, **do not** lower vehicle onto stands.
- Avoid accidental touching of exposed exhaust system on raised vehicles. Watch for air hoses and electrical cords which may be tripped over.
- Wear safety glasses while working under vehicle.



5. Before Lowering Lift:

- Remove all tools or other objects from lift area.
- Assure personnel are not in lift area.

6. To Lower Lift:

- Remain clear of lift when lowering vehicle. Keep Feet Clear!
- For M Series Lifts:
 - Actuate RAISE switch to raise lift off locking latches.
 - Actuate SAFETY LATCH RELEASE handle fully and hold.
 - Actuate LOWERING VALVE handle to lower, Fig. 1.

Note: Both LATCH release and LOWERING VALVE handles are deadman-type design. Each must be held down to lower lift. **Do not** override these self-closing lift controls.

- For E, Series Lifts:
 - Push  on control panel to raise lift off of locking latches.
 - Push  on control panel to lower lift.

7. Unloading:

- Remove adapters from under vehicle and swing arms to full drive-thru position before moving vehicle.
- Assure Exit area is clear of objects and personnel before removing vehicle from lift.

8. Power Off:

- Turn E-Stop switch to "OFF" position while lift is not in use.

Typical Wheel Spotting Positions

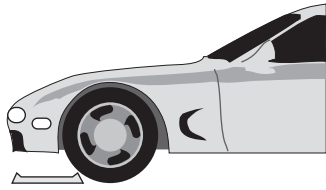

Less than 2.7 meter (105") wheelbase: position left front wheel on approach side of wheel dish.

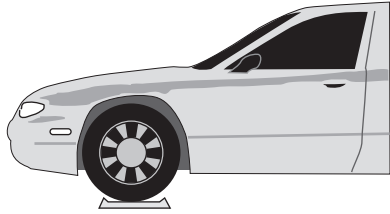

2.7 - 3.2 meter (105"-127") wheelbase: position left front wheel in wheel dish.

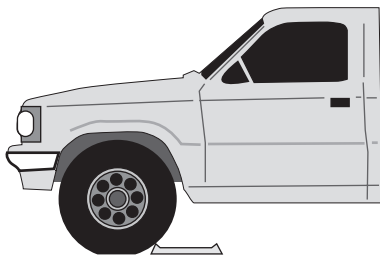

Larger than 3.2 meter (127") wheelbase: position left front just forward of wheel dish.

Fig. 3

⚠ WARNING Most specialty or modified vehicles cannot be raised on a frame engaging lift. Contact vehicle manufacturer for raising or jacking details.

Typical Lift Points

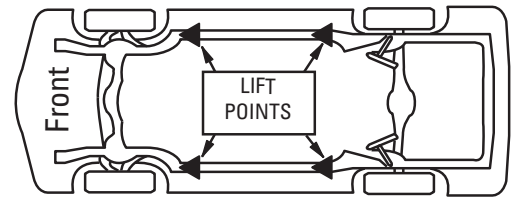

Perimeter Frame

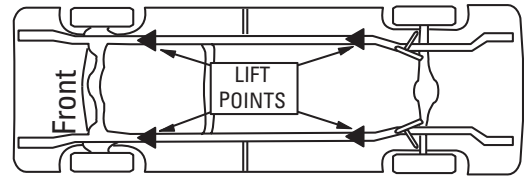

Pickup Truck

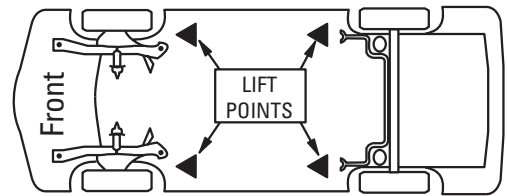

Unitized Body

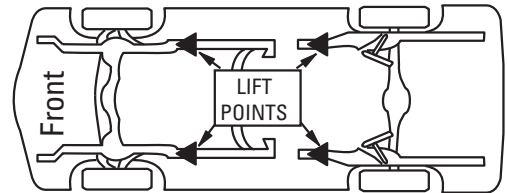

Stub Frame

Fig. 4

RESIDUAL RISKS

- Check the condition of the pickup points of the vehicle. Assure these points are not weakened due to rust, corrosion, damage, or modification.
- Vehicles with heavy material in the trunk or modified to carry equipment or tools, will have a changed center of gravity. Use stands when working on such vehicles.
- Assure cargo does not cause either individual axle weight to exceed one half lift capacity.

OPERATOR INSPECTION & MAINTENANCE

MAINTENANCE AUTHORIZED BY OPERATOR

- **Always** keep bolts tight. Check periodically.
- **Always** assure arm stop bolts are in place.
- **Always** keep lift components clean.
- **Always**, if oil leakage is observed, call local service representative.
- **Daily:** Check cables and sheaves for wear. If parts are worn, call local service representative.
- **Daily:** Inspect adapters for damage or excessive wear. If parts are worn, call local service representative.
- **Daily:** Check for permanent deformation to the latches. If present, call local service representative to replace parts.
- **Monthly:** Check equalizer cable tension. If parts are worn, call local service representative.
- **Monthly:** Check overhead sensor for function.
- **Every 3 Months:** Check anchor bolts for tightness. Anchors should be torqued to 200Nm (12.4kg-m).
- **Every 6 months:** Check fluid level of lift power unit and refill to proper level in level indicator with lift fully lowered.
- Replace all decals on the lift if unable to read or missing. Reorder labels from Rotary Lift.
- **Monthly:** Clean and check base of lift. Remove any rust and touch-up with paint.

TROUBLE SHOOTING FOR OPERATORS

FOR M SERIES LIFTS

Trouble	Cause	Remedy
Motor does not run.	1. Blown fuse or circuit breaker.	1. Replace blown fuse or reset circuit breaker. 2. Contact service representative for further assistance.
Motor runs but will not raise lift.	1. Low oil level.	1. Fill tank to MIN___ mark with ISOVG32 hydraulic oil or Dexron III ATF. 2. Contact service representative for further assistance.
Motor runs—raises unloaded lift but will not raise vehicle.	1. Overloading lift.	1. Check vehicle weight and/or balance vehicle weight on lift. 2. Contact service representative for further assistance.
Lift slowly settles down.	See Remedy	1. Contact service representative for further assistance.
Slow lifting speed or oil blowing out filler breather cap.	See Remedy	1. Contact service representative for further assistance.
Lift going up unlevel.	See Remedy	1. Contact service representative for further assistance.
Anchors will not stay tight.	See Remedy	1. Contact service representative for further assistance.
Locking latches do not engage.	See Remedy	1. Contact service representative for further assistance.
Locking latches do not disengage.	See Remedy	1. Contact service representative for further assistance.

TROUBLE SHOOTING FOR OPERATORS FOR E SERIES LIFTS

button actuated but lift doesn't raise

Trouble	Cause	Remedy
Motor won't run.	<ol style="list-style-type: none"> 1. Overhead Sensor Actuated. 2. Up button not functioning. 3. Incorrect voltage to power unit. 	<ol style="list-style-type: none"> 1. Check sensor for contact with vehicle. 2. Check UP button on opposite column if neither UP button is functioning contact service representative for further assistance. 3. Contact service representative for further assistance.
Motor runs but will not raise lift.	<ol style="list-style-type: none"> 1. Overloading lift. 	<ol style="list-style-type: none"> 1. Check vehicle weight and/or balance vehicle weight on lift. 2. Contact service representative for further assistance
Locking latches do not engage.	<ol style="list-style-type: none"> 1. Broken latch spring. 	<ol style="list-style-type: none"> 1. Contact service representative for further assistance.

button actuated but lift doesn't lower

Trouble	Cause	Remedy
Lift won't lower.	<ol style="list-style-type: none"> 1. Down button not functioning. 2. Safety Latches won't release. 3. Lowering Valve not functioning. 	<ol style="list-style-type: none"> 1. Contact service representative for further assistance. 2. Contact service representative for further assistance. 3. Contact service representative for further assistance.

button actuated but lift doesn't lower

Trouble	Cause	Remedy
Lift won't lower.	<ol style="list-style-type: none"> 1. Down button not functioning. 2. Lowering Valve not functioning. 	<ol style="list-style-type: none"> 1. Contact service representative for further assistance. 2. Contact service representative for further assistance.

REPAIR MAINTENANCE

MAINTENANCE AUTHORIZED BY QUALIFIED SERVICE REPRESENTATIVE ONLY

- **Lockout** all energy sources before beginning any repairs.
- **DO NOT** modify the lift in any manner without the prior written consent of the manufacturer.
- If electrical problems develop, make repairs according to local electrical codes. Use genuine Rotary Lift parts when replacement is necessary.
- **Replace** worn parts as required with Rotary Genuine Parts.
- Adjust equalizer cable tension per lift installation instructions.
- **Monthly:** Lubricate locking latch shafts. Actuate latch handle several times for oil to penetrate joints.

ANNUAL INSPECTION PERFORMED BY AUTHORIZED PERSONNEL ONLY

Aside from the routine checks that are stated under "Operator Maintenance", the following annual inspection is to be performed and a record of this inspection permanently retained on site. All deficiencies are to be corrected by the proper authorized personnel.

INSPECTION POINTS

- Check accessibility of the operating procedures.
- Check accessibility and readability of all labels.
- Check the rated load capacity of the lift.
- Examine all structural components including welds.
- Check electrical cords for insulation damage.
- Check fluid level.
- Check the lift controls for function.
- Check for proper function of swing arm restraints.
- Check all fastening devices for tightness including floor anchor bolts.
- Check exposed surfaces and edges.
- Operate the lift and check the operation of the positive stop and the lift safety latches.
- Check for proper operation of adapters.
- With a representative vehicle on the lift, check the lowering speed (not to exceed 0.15m/s).
- Check the operation of the synchronization or equalization system so that both sides raise and lower equally. Perform check with and without a vehicle representative load.
- Check the function of overhead sensor.
- Check all accessible piping, tubing, hose, valves and fittings. Review lift oil consumption records.
- Operate lift through full excursion and observe. Perform check with and without a vehicle representative load.
- With lift loaded, stop the lift at midpoint of travel and observe for drifting down and hydraulic leaks.
- Check with operator to ascertain any unusual operating characteristics.

TROUBLE SHOOTING FOR AUTHORIZED MAINTENANCE PERSONNEL FOR ALL LIFTS

Trouble	Cause	Remedy
Motor does not run.	<ol style="list-style-type: none"> 1. Blown fuse/circuit breaker. 2. Incorrect voltage to motor. 3. Bad wiring connections. 4. Motor up switch burned out. 5. Overhead limit switch burned out. 6. Motor windings burned out. 	<ol style="list-style-type: none"> 1. Replace fuse or reset breaker. 2. Supply correct voltage to motor. 3. Repair and insulate all connections. 4. Replace switch/control buttons. 5. Replace overhead limit switch. 6. Replace motor.
Motor runs but will not raise lift.	<ol style="list-style-type: none"> 1. Overloading lift. 2. Motor running on low voltage. 3. Debris in lowering valve. 4. Pump sucking air. 5. Suction stub off pump. 6. Low oil level. 7. Improper relief valve adjustment. 8. Open lowering valve. 	<ol style="list-style-type: none"> 1. Check vehicle weight and/or balance vehicle weight on lift. 2. Supply correct voltage to motor. 3. Clean lowering valve. 4. Tighten all suction line fittings. 5. Replace suction stub. 6. Fill tank to proper level with ISOVG32 hydraulic oil or Dexron III ATF 7. Replace relief valve. 8. Repair/replace lowering valve.
Lift slowly settles down.	<ol style="list-style-type: none"> 1. Debris in check valve seat. 2. Debris in lowering valve seat. 3. External oil leaks. 	<ol style="list-style-type: none"> 1. Clean check valve. 2. Clean lowering valve. 3. Repair external leaks.
Slow lifting speed or oil blowing out filler breather cap.	<ol style="list-style-type: none"> 1. Air mixed with oil. 2. Air mixed with oil suction. 3. Oil return tube loose. 	<ol style="list-style-type: none"> 1. Change oil to Dexron III ATF or ISOVG32 Hydraulic Oil. 2. Tighten all suction line fittings. 3. Reinstall oil return tube.
Lift going up unlevel.	<ol style="list-style-type: none"> 1. Equalizer cables out of adjustment. 2. Lift installed on unlevel floor. 	<ol style="list-style-type: none"> 1. Adjust equalizer cables to correct tension. 2. Shim lift to level columns (Not to exceed 13mm).*
Anchors will not stay tight.	<ol style="list-style-type: none"> 1. Holes drilled oversize. 2. Concrete floor thickness or holding strength not sufficient. 	<ol style="list-style-type: none"> 1. Relocate lift using new bit to drill holes. Reference installation instructions for proper anchoring method and minimum spacing requirements. 2. Break out old concrete and re-pour new pads for lift per lift installation instruction.
Lift stops short of full rise or chatters.	<ol style="list-style-type: none"> 1. Air in hydraulic lines or cylinder. 2. Low oil level. 	<ol style="list-style-type: none"> 1. Start unit, raise lift about 610mm. Open cylinder bleeders approximately 2 turns. Close bleeders when fluid streams. Fully lower lift and refill power unit per Step 2 below. 2. Fully lower lift. Fill tank to MIN___ mark with IS)VG32 Hydraulic Oil or Dexron III ATF.
Locking latches do not engage. (M Series lifts only.)	<ol style="list-style-type: none"> 1. Latch shafts rusted. (Usually occurs on outside installations or in high humidity areas such as wash bays.) 	<ol style="list-style-type: none"> 1. Remove covers, oil latch mechanism. Depress latch release handle several times to allow oil to coat shaft.
Locking latches do not disengage. (M Series lifts only.)	<ol style="list-style-type: none"> 1. Latch cable is broken. 2. Cable is off sheaves. 3. Latch cable is loose. 	<ol style="list-style-type: none"> 1. Replace cable. 2. Check position of upper sheaves. 3. Replace cable.

***Note:** Shim thickness of 51mm is possible by using optional shim kit #FC5393. Contact your authorized Rotary repair person.

EQUALIZER CABLE ADJUSTMENT

Checking and Adjusting Equalizer Cables:

Raise lift to check equalizer cable tension. Below carriage, grasp adjacent cables between thumb and forefinger, with about 67N effort you should just pull the cables together. Adjust at upper tie-offs (Fig. 5).

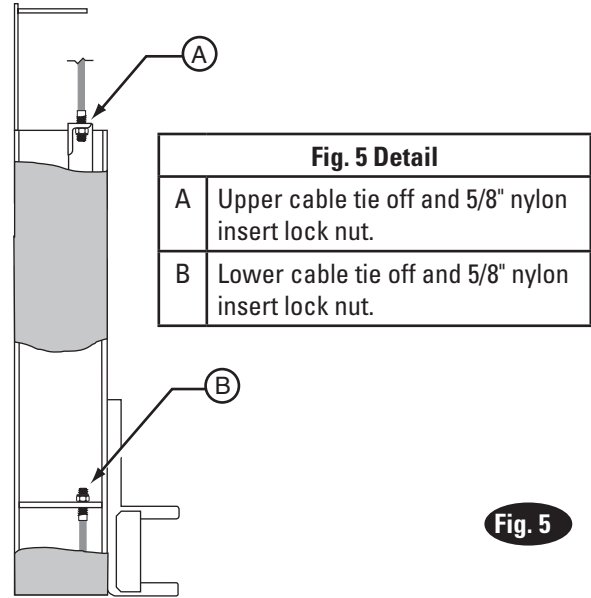

Fig. 5

LATCH CABLE ADJUSTMENT FOR M SERIES LIFTS

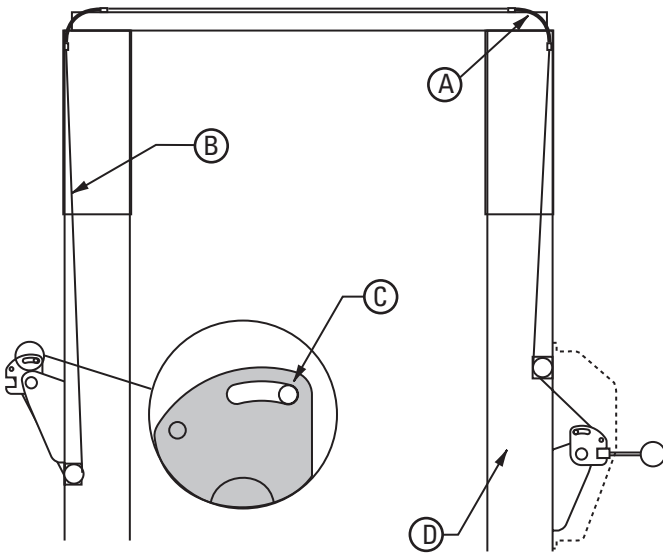

Fig. 6

Checking and Adjusting Locking Latch Cable:

1. Raise carriages past the first latch position and then lower onto latches.
2. Check that the latches have fully engaged when the latch handle is released. Be sure carriage is resting on latch dog.
3. Raise carriages fully off latches, actuate latch handle and check that the latches have fully disengaged.
4. Make necessary adjustments if required, see Fig. 7, recheck latch function. Latch handle must be positioned at the top of the latch control slot, Fig. 8.

Pull Control Plate down, making sure the Latch Dog itself does not move, to eliminate clearance between Control Plate slot and Latch Dog pin (Fig. 6). Loosen clamp and remove slack in the cable. Tighten the clamp.

Fig. 6 Detail	
A	Latch Cable Conduit Guide
B	Latch Cable
C	Notice the clearance removed between the control plate slot and the latch dog pin.
D	Right Column

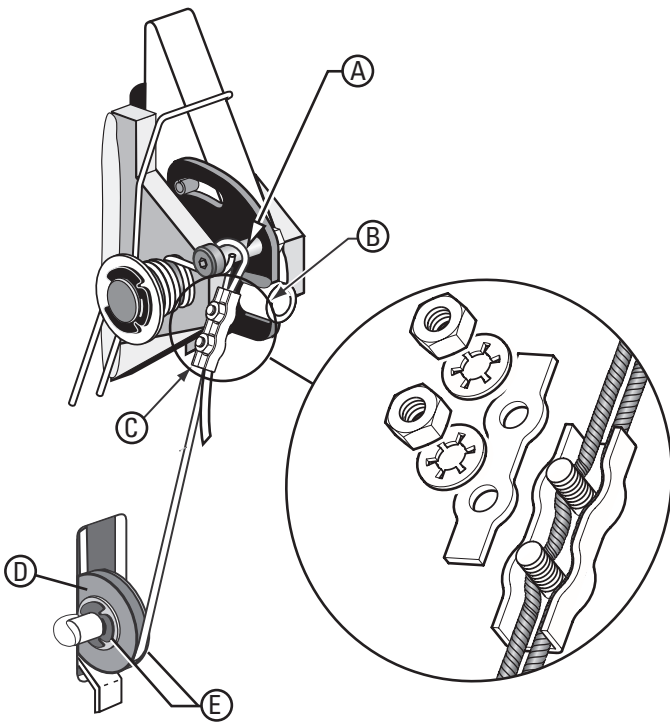

Fig. 7

Fig. 7 Detail	
A	Shoulder Bolt
B	Feed cable up through cable clamp, loop over end of shoulder bolt and feed back down through cable clamp.
C	Cable Clamp
D	Latch Cable Sheave
E	(2) 3/8" Retaining Rings

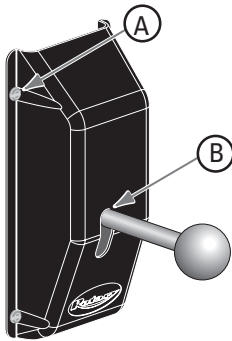

Fig. 8

Fig. 8 Detail	
A	5/16-18NCx3/8" Lg. BHMS
B	Latch handle MUST be positioned at the top of the latch control cover slot.

MANUAL LOWERING OF LIFT FOR E SERIES LIFTS ONLY

If your lift is in a raised position and you lose power it is important to know how to lower the lift manually. Make sure nothing is under the lifting structure of vehicle and all unauthorized personnel are away from the lift area.

1. Place a hydraulic jack and pipe under the carriage on the master control side. Jack should be rated to lift the capacity of the vehicle.
2. Raise lift off of the locking latch. You should only have to raise lift approximately 1/4" to disengage the lock.
3. Remove access panel from the control panel and pull locking latch back, Fig. 9. If you can not pull it back with your fingers then you don't have the latch off of the lock. Repeat Step 2 until lock is disengaged.
4. Place a flat piece of steel behind latch dog and back of column to keep it off of the lock.
5. Slowly lower hydraulic jack and pipe out from under the arm carriage.
6. Repeat step 1 thru 5 on slave control panel column.
7. The lift is now being held up by hydraulics at this point.
8. Remove cap from lowering valve on power unit and twist and pull to lower lift, Fig. 10. The lift will lower at a slow speed. Replace cap on lowering valve after the lift has been lowered.
9. If your facility lost power your lift will operate when you regain power.
10. If your facility power was not lost, have a certified electrician check wiring to lift or call an authorized Rotary repair person.

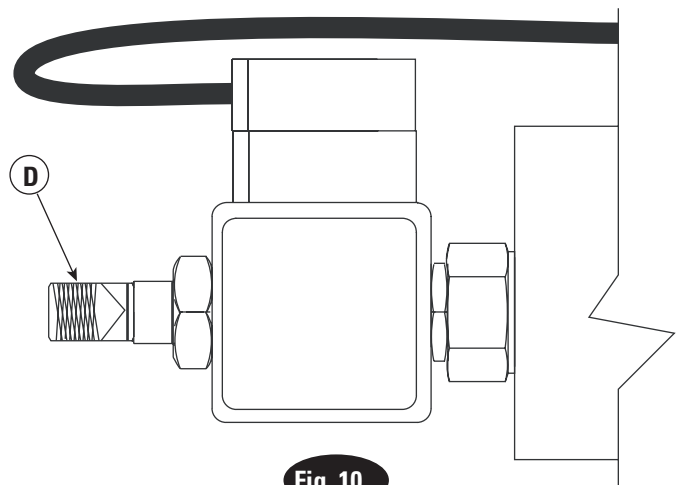
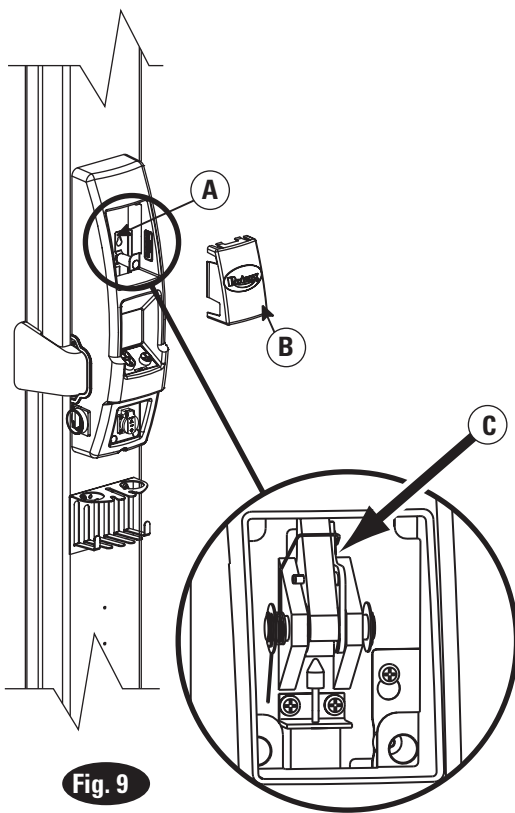

Side view of lowering valve located on power unit.

Fig. 9/Fig. 10 Detail	
A	Pull back locking latch
B	Access Panel
C	Locking Latch
D	Twist and pull to manually lower lift

EG-Konformitätserklärung EC Declaration of Conformity

im Sinne der EG-Richtlinie 2006/42/EG über Maschinen (Anhang II A)
according to EC directive 2006/42/EC on machinery (Annex II A)

Name und Anschrift des Herstellers /
Name and address of the manufacturer :

BlitzRotary GmbH
Hüfing Str.55
78199 Bräunlingen, Germany

Diese Erklärung bezieht sich nur auf die Maschine in dem Zustand, in dem sie in Verkehr gebracht wurde; vom Endnutzer nachträglich angebrachte Teile und/oder nachträglich vorgenommene Eingriffe bleiben unberücksichtigt. Die Erklärung verliert ihre Gültigkeit, wenn das Produkt ohne Zustimmung umgebaut oder verändert wird.
This declaration relates exclusively to the machinery in the state in which it was placed on the market, and excludes components which are added and/or operations carried out subsequently by the final user. The declaration is no more valid, if the product is modified without agreement.

Hiermit erklären wir, dass die nachstehend beschriebene Maschine
Herewith we declare, that the machinery described below

Produktbezeichnung / product denomination:
Serien- / Typenbezeichnung / model / type:

2-Säulen-Hebebühne / 2-post vehicle lift
SPOA30
Tragfähigkeit 3100 kg / capacity 3100 kg

Maschinen-/Seriennummer / machinery / serial number:

.....

Baujahr / Year of manufacture:

20...

allen einschlägigen Bestimmungen der Maschinenrichtlinie 2006/42/EG entspricht.
Die Maschine entspricht zusätzlich den Bestimmungen der Richtlinien 2004/108/EG über elektromagnetische Verträglichkeit 2006/95/EG über elektrische Betriebsmittel EG (*Schutzziele wurden gemäß Anhang I, Nr. 1.5.1 der Maschinenrichtlinie 2006/42/EG eingehalten*).

is complying with all essential requirements of the Machinery Directive 2006/42/EC.

In addition the partly completed machinery is in conformity with the EC Directives 2004/108/EC relating to electromagnetic compatibility and 2006/95/EC relating to electrical equipment (Protection objectives have been met in accordance with Annex I No. 1.5.1 of the Machinery Directive 2006/42/EC).

Angewandte harmonisierte Normen / Harmonised Standards used

EN 1493:1998+A1:2008	Fahrzeug-Hebebühnen / Vehicle lifts
EN ISO 12100-1 : 2003	Sicherheit von Maschinen - Grundbegriffe / Safety of Machinery- Basic concepts
EN ISO 12100-2 : 2003	Sicherheit von Maschinen - Grundbegriffe / Safety of Machinery- Basic concepts
EN 60204-1:2006+7/2007	Elektrische Ausrüstung von Maschinen / Electrical equipment of machines
EN 349:1993+A1:2008	Sicherheit von Maschinen-Mindestabstände / Safety of machinery - Minimum gaps
EN ISO 13850:2008	Sicherheit von Maschinen-Not-Halt / Safety of machinery - Emergency stop
EN ISO 14121-1:2007	Sicherheit von Maschinen-Risikobeurteilung / Safety of machinery - Risk assessment

Angewandte sonstige technische Normen und Spezifikationen

Other technical standards and specifications used:

BGG 945	Prüfung von Hebebühnen / inspection of vehicle lifts
BGR 500	Betreiben von Arbeitsmitteln / management of working appliances
BGV A3	Unfallverhütungsvorschrift elektrische Anlagen und Betriebsmittel / law accident prevention regulation of electric facilities and equipment

Bevollmächtigter für die Zusammenstellung der relevanten technischen Unterlagen:

The person authorised to compile the relevant technical documentation:

Herr Pohl; Hüfing Str. 55; 78199 Bräunlingen

Ort / Place : Bräunlingen

Datum / Date : 21.12.2009



Carsten Rohde
Geschäftsführer / Managing Director

EG-Konformitätserklärung EC Declaration of Conformity

im Sinne der EG-Richtlinie 2006/42/EG über Maschinen (Anhang II A)
according to EC directive 2006/42/EC on machinery (Annex II A)

Name und Anschrift des Herstellers /
Name and address of the manufacturer:

BlitzRotary GmbH
Hüfing Str.55
78199 Bräunlingen, Germany

Diese Erklärung bezieht sich nur auf die Maschine in dem Zustand, in dem sie in Verkehr gebracht wurde; vom Endnutzer nachträglich angebrachte Teile und/oder nachträglich vorgenommene Eingriffe bleiben unberücksichtigt. Die Erklärung verliert ihre Gültigkeit, wenn das Produkt ohne Zustimmung umgebaut oder verändert wird.
This declaration relates exclusively to the machinery in the state in which it was placed on the market, and excludes components which are added and/or operations carried out subsequently by the final user. The declaration is no more valid, if the product is modified without agreement.

Hiermit erklären wir, dass die nachstehend beschriebene Maschine
Herewith we declare, that the machinery described below

Produktbezeichnung / product denomination:
Serien- / Typenbezeichnung / model / type:

2-Säulen-Hebebühne / 2-post vehicle lift
SPO40 / SPOA40
Tragfähigkeit 4000 kg / capacity 4000 kg

Maschinen-/Seriennummer / machinery / serial number:

.....

Baujahr / Year of manufacture:

20...

allen einschlägigen Bestimmungen der Maschinenrichtlinie 2006/42/EG entspricht.
Die Maschine entspricht zusätzlich den Bestimmungen der Richtlinien 2004/108/EG über elektromagnetische Verträglichkeit 2006/95/EG über elektrische Betriebsmittel EG (*Schutzziele wurden gemäß Anhang I, Nr. 1.5.1 der Maschinenrichtlinie 2006/42/EG eingehalten*).

is complying with all essential requirements of the Machinery Directive 2006/42/EC.

In addition the partly completed machinery is in conformity with the EC Directives 2004/108/EC relating to electromagnetic compatibility and 2006/95/EC relating to electrical equipment (Protection objectives have been met in accordance with Annex I No. 1.5.1 of the Machinery Directive 2006/42/EC).

Angewandte harmonisierte Normen / Harmonised Standards used

EN 1493:1998+A1:2008	Fahrzeug-Hebebühnen / Vehicle lifts
EN ISO 12100-1 : 2003	Sicherheit von Maschinen - Grundbegriffe / Safety of Machinery- Basic concepts
EN ISO 12100-2 : 2003	Sicherheit von Maschinen - Grundbegriffe / Safety of Machinery- Basic concepts
EN 60204-1:2006+7/2007	Elektrische Ausrüstung von Maschinen / Electrical equipment of machines
EN 349:1993+A1:2008	Sicherheit von Maschinen-Mindestabstände / Safety of machinery - Minimum gaps
EN ISO 13850:2008	Sicherheit von Maschinen-Not-Halt / Safety of machinery - Emergency stop
EN ISO 14121-1:2007	Sicherheit von Maschinen-Risikobeurteilung / Safety of machinery - Risk assessment

Angewandte sonstige technische Normen und Spezifikationen

Other technical standards and specifications used:

BGG 945	Prüfung von Hebebühnen / inspection of vehicle lifts
BGR 500	Betreiben von Arbeitsmitteln / management of working appliances
BGV A3	Unfallverhütungsvorschrift elektrische Anlagen und Betriebsmittel / law accident prevention regulation of electric facilities and equipment

Bevollmächtigter für die Zusammenstellung der relevanten technischen Unterlagen:

The person authorised to compile the relevant technical documentation:

Herr Pohl; Hüfing Str. 55; 78199 Bräunlingen

Ort / Place : Bräunlingen

Datum / Date : 21.12.2009



Carsten Rohde
Geschäftsführer / Managing Director

**Trained Operators and Regular Maintenance Ensures
Satisfactory Performance of Your Rotary Lift.**

Replacement Parts: See installers package for parts breakdown sheet. Order Genuine Rotary replacement parts from your nearest Authorized Parts Distributor.

Maintenance Assistance: Contact your local Rotary distributor.

Should further assistance be required, contact Rotary Lift, at one of the phone numbers listed below.

World Headquarters:
Rotary Lift
A **DOVER** COMPANY
2700 Lanier Drive
Madison, Indiana USA
Phone: 1.800.445.5438
Phone: 1.812.273.1622
Fax: 1.800.578.5438
Fax: 1.812.273.6502
userlink@rotarylif.com
www.rotarylif.com

Germany:
(European Headquarters)
BlitzRotary GmbH
Hüfingerring Straße 55
D-78199 Bräunlingen
Telefon +49.771.9233.0
Telefax +49.771.9233.99
info@blitzrotary.com
www.blitzrotary.com

Canada:
(Regional Sales Office)
Rotary Lift Canada
Mississauga, Ontario
Phone: 888.256.4195
Phone: 905.812.9920
Fax: 905.812.9719
canada@rotarylif.com

United Kingdom:
(Regional Sales Office)
Rotary Lift (UK) LTD.
Halstead, Essex
Phone: +44.178.747.7711
Fax: +44.178.747.7720
sales@rotarylif.idps.co.uk

Austral-Asia:
(Regional Sales Office)
Rotary Lift Austral/Asia
Shah Alam, Selangor, Malaysia
Phone: +60.3.5192.5910
Fax: +60.3.5192.5910
sothman@rotarylif.com

