

TIRE CHANGER

ELECTRO-HYDRAULIC TIRE CHANGER

NAV51.15 Mounting head and mounting lever, fully automatic movement of the tool arm, cable console unit, truck, bus, agricultural and large EM, rim diameter: 11" - 43", max wheel width 1500mm.

NAV51.15 Premium Mounting head and mounting lever, fully automatic movement of the tool arm, cable console unit, incl. kit for fitting without a lever, truck, bus, agricultur and large EM, rim diameter: 11" - 43", max wheel width 1500mm.

+ 11" - 43" (56" with extension set) electro-hydraulic tire changer for large EM, agriculture, truck, and bus tires
+ Leverless kit - the mounting device enters between bead and rim, raises the bead, and removes the tire (NAV51.15 Premium)

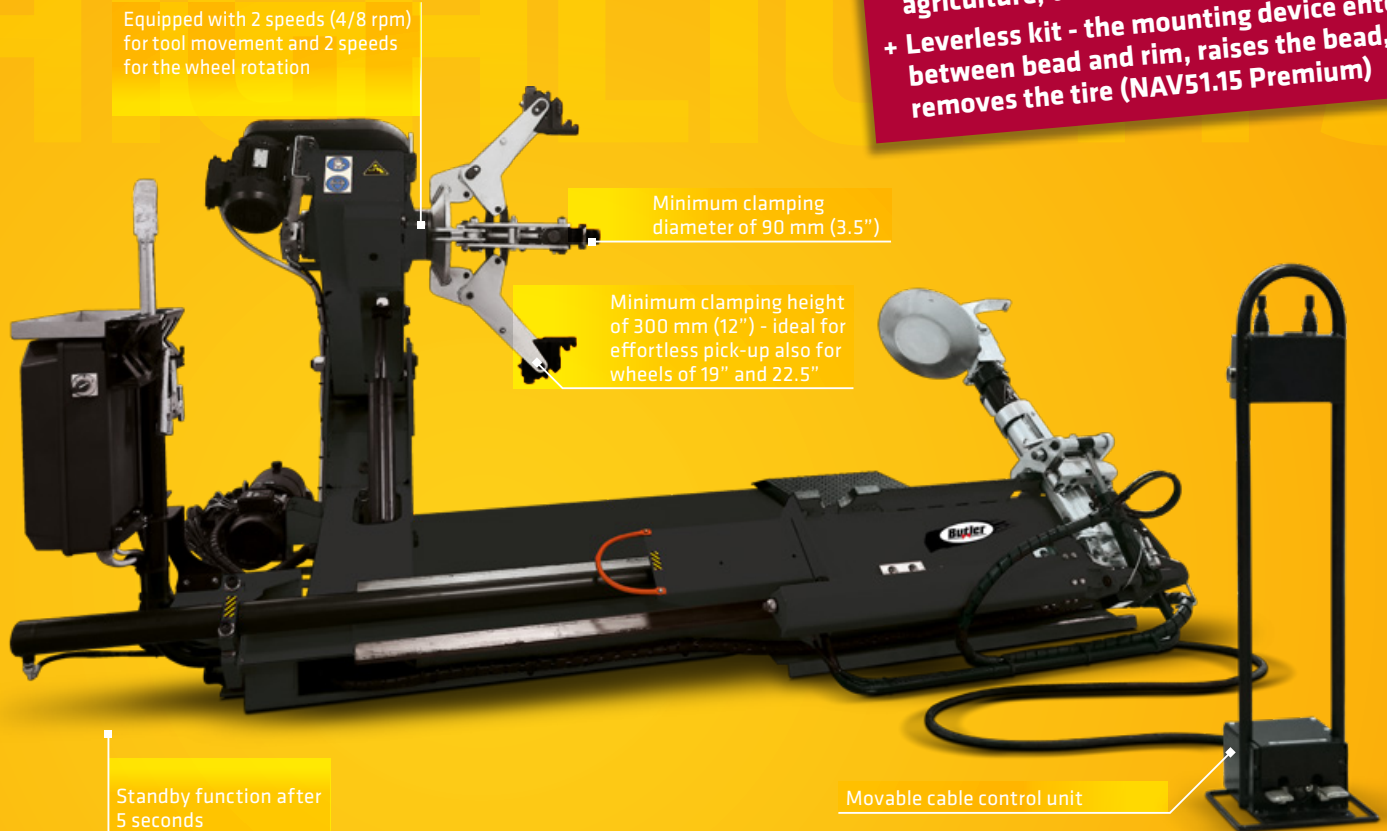

HIGHLIGHTS IN DETAIL

1

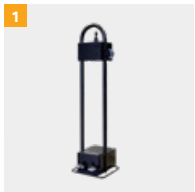

2



1 Cable operating unit

2 Fully automatic movement of the tool arm (rotation, lifting, and shifting)

3 Double latching hook for the mounting tool (NAV51.15 Premium)

4 Large bead-raising lever and rim clamp included in the scope of deliveries

3



4

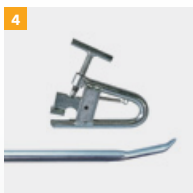

NAV51.15 / NAV51.15 Premium

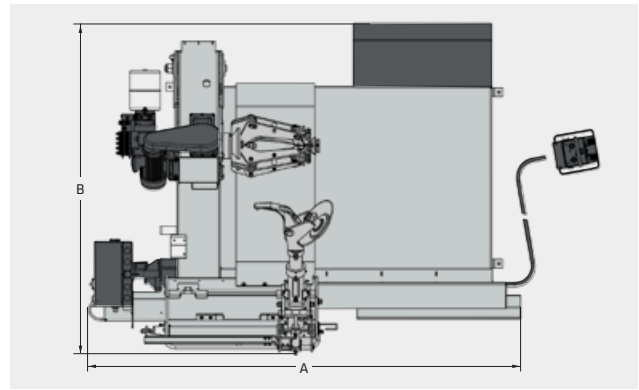
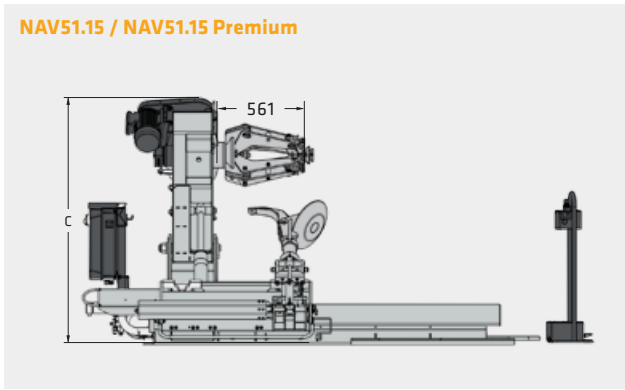

Model	NAV51.15	NAV51.15 Premium
Clamping range	11 - 43 bzw. 56"	11 - 43 bzw. 56"
Wheel width max.	1500 mm	1500 mm
Wheel diameter max.	2550 mm	2550 mm
Wheel weight max.	2300 kg	2300 kg
Automatic bead-breaking movement	X	X
Bead-breaking force	34000 N	34000 N
Rotation speed	4 / 8 rpm	4 / 8 rpm
Torque max.	5000 Nm	5000 Nm
Power clamping plate motor	1,3 / 1,85 kW	1,3 / 1,85 kW
Power hydraulic motor	1,8 / 2,5 kW	1,8 / 2,5 kW
Electrical connection	400 V	400 V
Mains frequency	50 Hz	50 Hz
Phases	3	3
Fuse protection	16 A träge	16 A träge
A Width	2804 mm	2804 mm
B Depth	2145 mm	2145 mm
C Height	1595 mm	1595 mm
Weight	980 kg	980 kg
Article number	811864	811865

ACCESSORIES

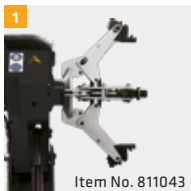

- 1** Extension kit up to 56" rim
- 2** Jaws protection for aluminum rims
- 3** Pneumatic bead pusher
- + Short, patented mounting iron (811102)
- + Mounting iron standard truck (811915)
- + Clamp for alloy rims (811047)
- + Clamp for EM rims (811103)
- + Assembly paste 3.5 kg (811076)
- + Bead breaker roller for tubeless tyres (G90A2)
- + Inverter-controlled speed - 1 / 5 / 10 U/min
- + Leverless kit (not retrofittable) - included in scope of delivery for NAV51.15 PREMIUM