

# TIRE CHANGER

## ELECTRO-HYDRAULIC TIRE CHANGER

**NAV11N** Mounting head and mounting lever, manual movement of the tool arm, hydraulic console unit, truck, bus and agricultur, rim diameter: 11" - 27", max wheel width 925mm.

**NAV11N Premium** Mounting head and mounting lever, manual movement of the tool arm, hydraulic operating unit, foot pedal, incl. kit for fitting without a lever, truck, bus and agricultur, rim diameter: 11" - 27", max wheel width 925mm.

+ 11" - 27" electro-hydraulic tire changer  
for truck and bus tires  
+ Ideal also for mobile service

Minimum clamping height of 370 mm (14.5") - ideal for effortless pick-up from the floor for rims of 22.5"

Minimum clamping diameter of 90 mm (3.5") - the stepped clamping jaw allows clamping from 90 mm up without use of accessories

Tool rotation with quick unlocking

Manual movement of the tool arm

Operating console can be rotated by 120°

## HIGHLIGHTS IN DETAIL

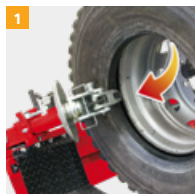

**1** Leverless kit, the mounting device enters between bead and rim, raises the bead, and removes the tire (NAV11N Premium)

**2** Hydraulic operating unit

**3** Short, patented mounting lever

+ Equipped with one speed



## NAV11N / NAV11N Premium

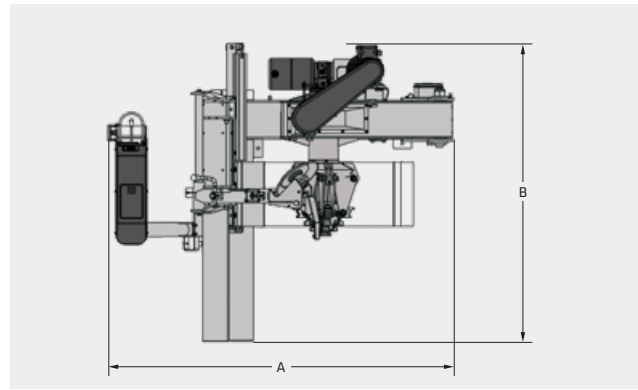
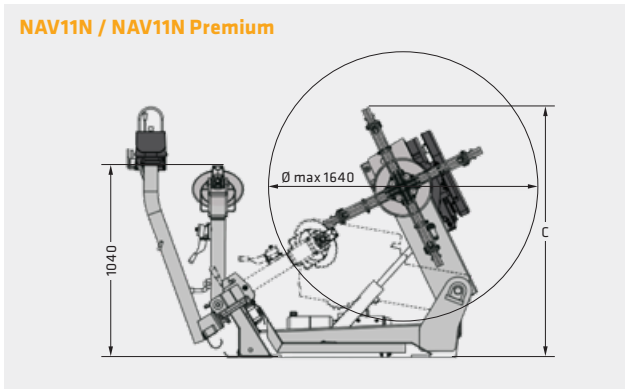

Model	NAV11N	NAV11N Premium
Clamping range	11" - 27"	11" - 27"
Wheel width max.	925 mm	925 mm
Wheel diameter max.	1640 mm	1640 mm
Wheel weight max.	1700 kg	1700 kg
Automatic bead-breaking movement	X	X
Bead-breaking force	16000 N	16000 N
Rotation speed	8 rpm	8 rpm
Torque max.	2500 Nm	2500 Nm
Power clamping plate motor	2,2 kW	2,2 kW
Power hydraulic motor	0,75 kW	0,75 kW
Electrical connection	400 V	400 V
Mains frequency	50 Hz	50 Hz
Phases	3	3
Fuse protection	16 A träge	16 A träge
<b>A</b> Width	1780 mm	1780 mm
<b>B</b> Depth	1620 mm	1620 mm
<b>C</b> Height	1360 mm	1360 mm
Weight	454 kg	454 kg
Article number	810141	810143

## ACCESSORIES

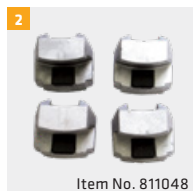
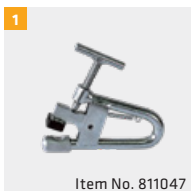

- 1** Clamp for alloy rims
- 2** Jaws protection for aluminum rims
  - + Short, patented mounting iron (811102)
  - + Clamp for EM rims (811103)
  - + Bead breaker roller for tubeless tyres (G108A36)
  - + Mounting iron standard truck (811915)
  - + Assembly paste 3.5 kg (811076)