



1297-M005-03

**G4.140R
G4.140WS
G4.140WSLB
GP4.140WS**

INSTRUCTION MANUAL

EN

TRANSLATION FROM THE
ORIGINAL INSTRUCTIONS

For spare parts drawings refer to "LIST OF COMPONENTS" section.

- For any further information please contact your local dealer or call:

Technical services: **RAVAGLIOLI S.p.A.** - Via 1° Maggio, 3 - 40037 Pontecchio Marconi - Bologna Italy
Phone (+39) 051 6781511 - Telex 510697 RAV I - Fax (+39) 051 846349 - e-mail: aftersales@ravaglioli.com

1297-M005-03 - Rev. n. 03 (01/2021)

**SUMMARY**

1.0 GENERAL INTRODUCTION _____	9	12.4 Correct positioning of the ultrasound Run-out detecting device (optional on some models) _____	30
1.1 Introduction _____	9		
2.0 INTENDED USE _____	9	13.0 CONTROL PANEL _____	30
2.1 Training of personnel _____	9		
3.0 SAFETY DEVICES _____	10	14.0 WHEEL BALANCING _____	31
3.1 Residual risks _____	10	14.1 Switching the machine on and off _____	31
4.0 GENERAL SAFETY RULES _____	11	14.2 Balancing programs setting _____	32
5.0 PACKING AND MOBILIZATION FOR TRANSPORT _____	12	14.2.1 Programs rapid setting and measurements through distance- diameter caliper arm _____	33
6.0 UNPACKING _____	12	14.2.2 Programs setting through “Measurements acquisition” screen page _____	36
7.0 MOBILIZATION _____	13	14.3 Indicative display of points where to detect measures/to fit weight _____	37
8.0 WORKING ENVIRONMENT CONDITIONS _____	13	14.3.1 Weights positioning _____	38
8.1 Working area _____	13	14.4 Displaying the active/modifiable field _____	38
8.2 Lighting _____	14	14.5 Wheel balancing screen page description _____	39
9.0 MACHINE ASSEMBLY _____	14	14.5.1 Balancing mode _____	41
9.1 Anchoring system _____	14	14.6 Use of machines with disabled automatic data gauge _____	44
9.2 Assembly procedures _____	15	14.6.1 Manual setting of wheel dimensions _____	44
9.2.1 Fitting the chuck on the flange _____	15	14.7 Standard balancing programs _____	44
9.2.2 Fitting and removal of the pneumatic chuck on the flange _____	15	14.7.1 Static _____	44
9.2.3 Monitor fitting _____	17	14.7.2 Static-1 _____	45
9.2.4 Touch-screen monitor fitting (optional) _____	18	14.7.3 Static-2 _____	45
9.2.5 Fitting the protection guard _____	19	14.7.4 Dynamic _____	45
9.2.6 Fitting of wheel external data gauge (standard on some models) _____	20	14.7.5 ALU-S _____	45
9.2.7 Fitting of external data gauge / Run-out (optional on some models) _____	21	14.7.6 ALU-S1 _____	46
9.2.8 Fitting of ultrasound Run-out (standard on some models) _____	22	14.7.7 ALU-S2 _____	46
9.2.9 Fitting of ultrasound Run-out with support (standard on some models) _____	23	14.7.8 ALU-1 _____	46
10.0 ELECTRICAL CONNECTIONS _____	24	14.7.9 ALU-2 _____	46
10.1 Electrical checks _____	25	14.7.10 ALU-3 _____	47
11.0 AIR CONNECTION _____	25	14.7.11 ALU-4 _____	47
12.0 FITTING THE WHEEL ON THE CHUCK _____	26	14.8 Optional balancing programs _____	47
12.1 Wheel assembly _____	26	14.8.1 ECO-WEIGHT mode _____	47
12.2 Wheel assembly _____	27	14.8.2 SPLIT mode _____	49
12.3 Adjustment of ultrasound sensor support (standard on some models) _____	29	14.8.3 Weights hidden behind spokes mode _____	51
		14.8.4 Matching mode _____	52
		14.9 Special balancing programs _____	55
		14.9.1 Pax _____	55
		14.10 Recalculation function _____	55
		14.11 Wheel balancing in Motorcycle mode (with distance caliper extension Kit) _____	56
		15.0 USER MENU (OPTIONS AND CALIBRATION) _____	56
		15.1 Options menu _____	57



15.1.1 Lower weight limit _____	59	16.0 ERROR SIGNALS _____	70
15.1.2 Setting adhesive weight dimensions and static threshold percentage _____	59	17.0 ROUTINE MAINTENANCE _____	71
15.1.3 User management _____	60	18.0 TECHNICAL DATA _____	72
15.2 Enabling of electronic Run-out measuring device (optional) _____	60	18.1 Technical electrical data _____	72
15.3 Machine calibrations _____	61	18.2 Technical mechanical data _____	72
15.3.1 Chuck "0" (zero) calibration _____	62	18.3 Dimensions _____	73
15.3.2 Weight measurement sensors calibration _____	62	19.0 STORING _____	74
15.3.3 Gauges calibration _____	64	20.0 SCRAPPING _____	74
15.3.4 Mobile laser pointer calibration (standard on some models) _____	68	21.0 REGISTRATION PLATE DATA _____	74
15.3.5 Touch screen monitor calibration (for touch screen monitors) (optional) _____	69	22.0 FUNCTIONAL DIAGRAMS _____	74
		Drawing A - Electrical connection diagram _____	75
		Drawing B - Pneumatic connection diagram _____	77



Feature / Fixtures Versions	Model	G4.140R	G4.140WS	G4.140WSLB	GP4.140WS
Monitor		•	•	•	•
Threaded chuck		•	•	•	
Pneumatic chuck					•
Pedal brake		•	•	•	
Foot pedal / chuck open-close pedal					•
Pressure reducer filter unit					•
Protection guard		•	•	•	•
Wheels width external data gauge		•			
Automatic width measuring device unit			•	•	•
Sizing body			•	•	•
Pressure ring		•	•	•	•
Car ring nut		•	•	•	
Tyre locking sleeve					•
Cones		•	•	•	•
Manual caliper		•	•	•	•
Weight pliers		•	•	•	•
Carriages counterweight		•	•	•	•
External data gauge/ Run-out		OPT			
Ultrasound Run-out		OPT			
6 o'clock laser		OPT			
"12 o'clock" laser device		OPT	OPT	OPT	OPT
Ultrasound run-out with support			OPT	OPT	OPT
Flange with gauge		OPT	OPT	•	OPT
Wheel protection disc		OPT	OPT	•	OPT
Short studs kit		OPT	OPT	•	OPT
Printer kit		OPT	OPT	OPT	OPT
Keyboard version for touch screen		OPT	OPT	OPT	OPT
Touch screen monitor version		OPT	OPT	OPT	OPT

• = standard

OPT = optional

GENERAL DESCRIPTION

Fig. 1

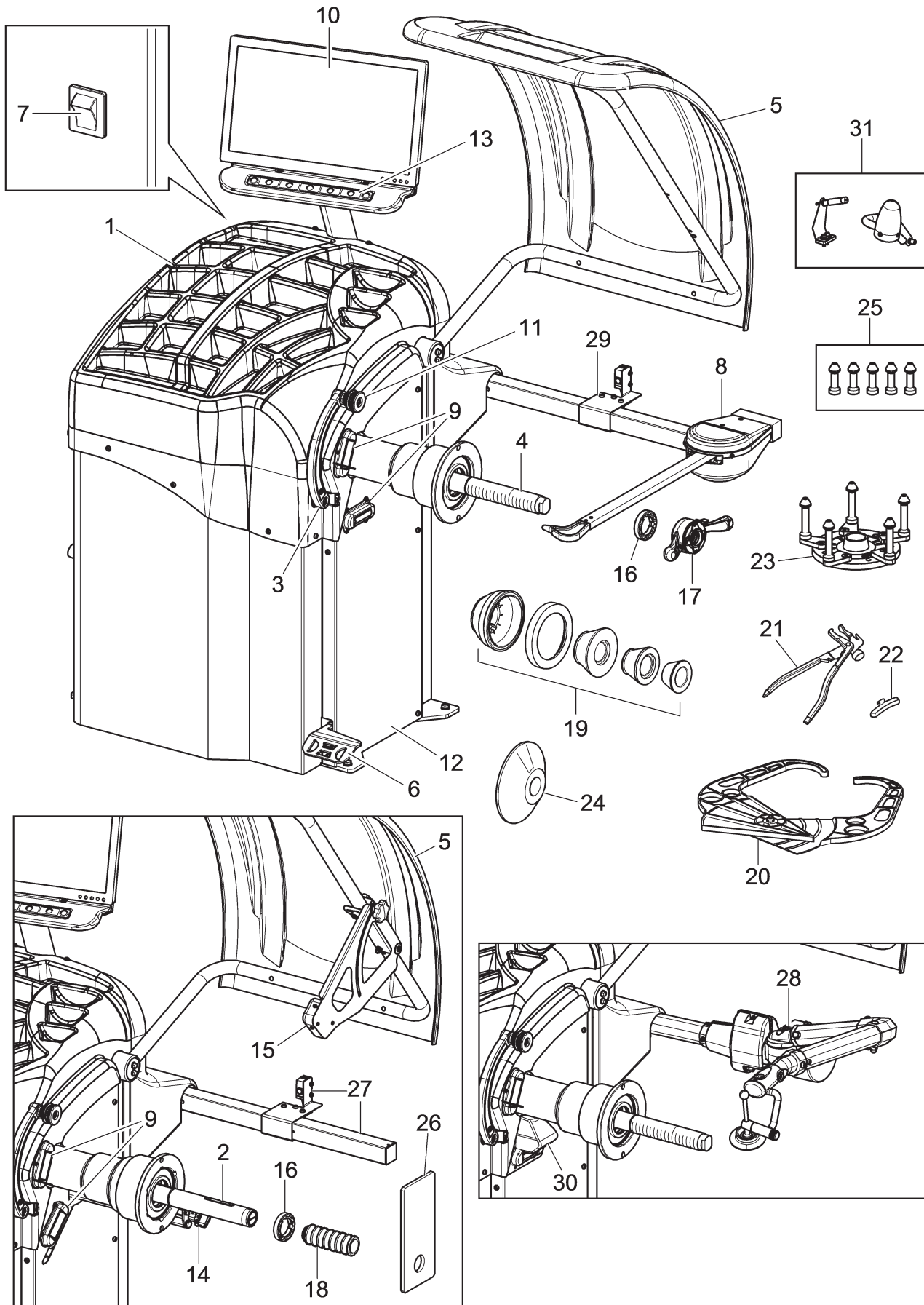













**KEY (Fig. 1)**

- 1 - Weight holding bridge
- 2 - Pneumatic chuck
- 3 - Distance-diameter caliper
- 4 - Threaded chuck
- 5 - Protection guard
- 6 - Pedal brake (for all models)
Chuck open-close pedal (on models with
pneumatic chuck)
- 7 - Main switch
- 8 - Wheel external data gauge (standard on some
models)
- 9 - Led light unit
- 10 - Monitor
- 11 - Grippers for weight fitting
- 12 - Lateral guard
- 13 - 7-keys keyboard
- 14 - Mobile laser pointer (standard on some models)
- 15 - Automatic width measuring
device unit (standard on some models)
- 16 - Pressure ring
- 17 - Car ring nut (on models with threaded chuck)
- 18 - Pneumatic locking sleeve (on models with
pneumatic chuck)
- 19 - Cones
- 20 - Manual caliper
- 21 - Grippers for weights
- 22 - Carriages counterweight
- 23 - Flange with gauge (standard on some models)
- 24 - Wheel protection plate (standard on some
models)
- 25 - Short studs kit (standard on some models)
- 26 - Sizing body (standard on some models)
- 27 - Ultrasound run-out with support (optional on
some models)
- 28 - External data gauge / Run-out (optional on
some models)
- 29 - Ultrasound Run-out (optional on some
models)
- 30 - 6 o'clock laser pointer (optional on some
models)
- 31 - "12 o'clock" laser device (optional)



SYMBOLS USED IN THE MANUAL

Symbols	Description
	Read instruction manual.
	Wear work gloves.
	Wear work shoes.
	Wear safety goggles.
	Mandatory. Operations or jobs to be performed compulsorily.
	Warning. Be particularly careful (possible material damages).

Symbols	Description
	Danger! Be particularly careful.
	Note. Indication and/or useful information.
	Move with fork lift truck or pallet truck.
	Lift from above.
	Attention: never lift the machine by means of the chuck.
	Danger! Laser presence.

INFORMATION PLATE LOCATION DRAWING

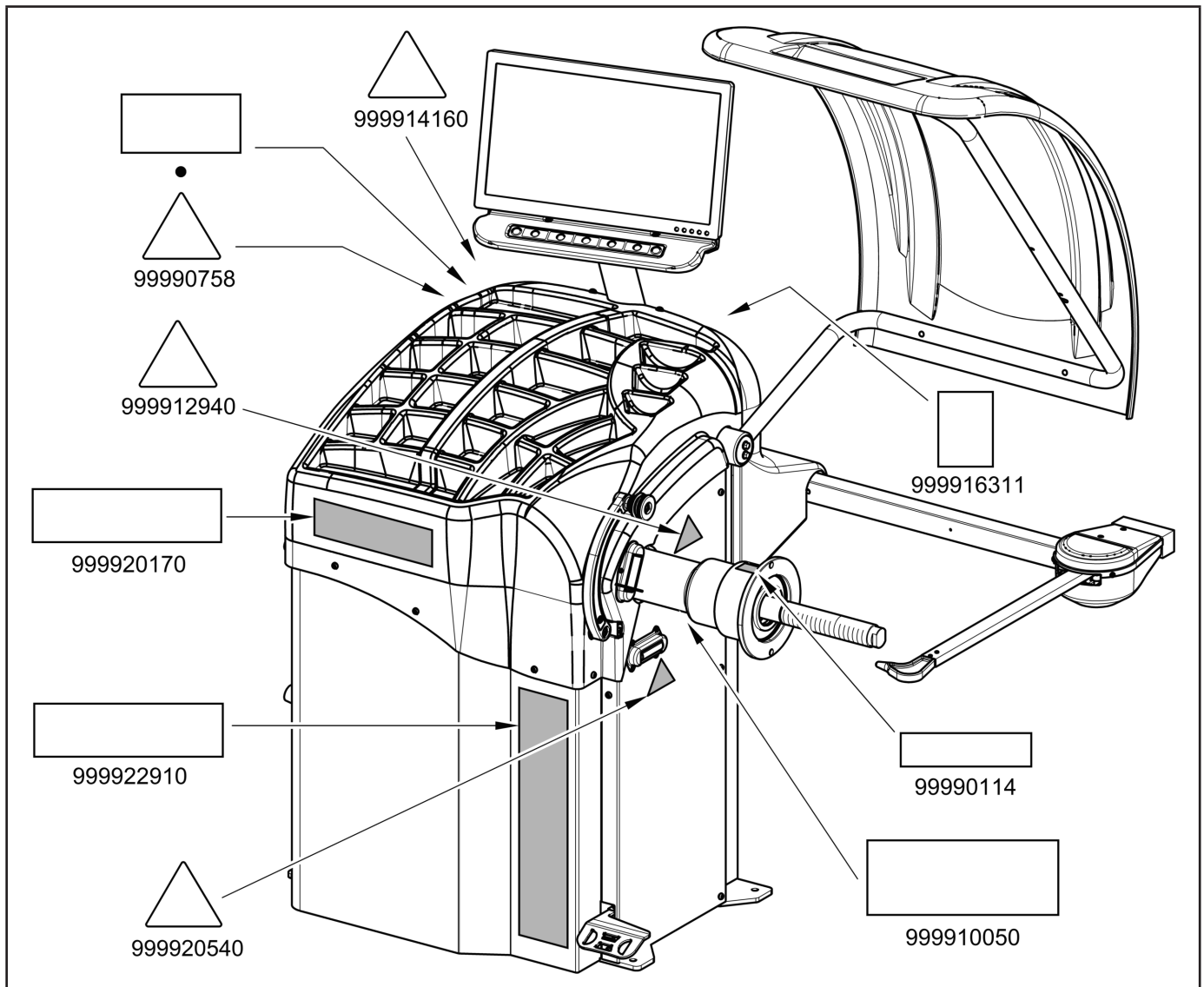

Code numbers of plates

99990114	<i>Arrow plate</i>
99990758	<i>Electric shock danger plate</i>
999910050	<i>Protection device use plate</i>
999912940	<i>Lifting plate</i>
999914160	<i>Voltage 230V 50/60 Hz 1 Ph plate</i>
999916311	<i>Skip plate</i>
999920170	<i>Machine nameplate</i>
999920540	<i>Laser point danger plate (standard on some models)</i>
999922910	<i>Manufacturer trademark nameplate</i>
•	<i>Serial number plate</i>



IF ONE OR MORE PLATES DISAPPEAR FROM THE MACHINE OR BECOMES DIFFICULT TO READ. REPLACE IT AND QUOTE ITS/THEIR CODE NUMBER/S WHEN REORDERING.



SOME OF THE PICTURES AND/OR DISPLAY SCREEN PAGES PRESENT IN THIS MANUAL HAVE BEEN OBTAINED FROM PICTURES OF PROTOTYPES, THEREFORE THE STANDARD PRODUCTION MACHINES AND ACCESSORIES CAN BE DIFFERENT IN SOME COMPONENTS/DISPLAY SCREEN PAGES.

1.0 GENERAL INTRODUCTION

This manual is an integral part of the product and must be retained for the whole operating life of the machine.

Carefully study the warnings and instructions contained in this manual. It contains important instructions regarding **FUNCTIONING, SAFE USE and MAINTENANCE.**



KEEP THE MANUAL IN A KNOWN, EASILY ACCESSIBLE PLACE FOR ALL ACCESSORY OPERATORS TO CONSULT IT WHENEVER IN DOUBT.



THE MANUFACTURER DISCLAIMS ALL RESPONSIBILITY FOR ANY DAMAGE OCCURRED WHEN THE INDICATIONS GIVEN IN THIS MANUAL ARE NOT RESPECTED: AS A MATTER OF FACT, THE NON-COMPLIANCE WITH SUCH INDICATIONS MIGHT LEAD TO EVEN SERIOUS DANGERS.

1.1 Introduction

Thank you for preferring this wheel balancer. We feel sure you will not regret your decision.

This machine has been designed for use in professional workshops and stands out for its reliability and easy, safe and rapid operation. With just a small degree of maintenance and care, this wheel balancer will give you many years of trouble-free service and lots of satisfaction.

2.0 INTENDED USE

The machines described in this manual and their different versions, are wheels balancing machines for car and light transport, projected to be used exclusively to cancel out, or at least reduce to acceptable limits the vibrations of the wheels, by fitting counterweights of suitable size and in specific positions to the same wheels that are not correctly balanced.



DANGER: EMPLOYING THESE MACHINES OUTSIDE THE USE DESTINATION THEY HAVE BEEN DESIGNED FOR (AS INDICATED IN THIS MANUAL) IS INAPPROPRIATE AND DANGEROUS.



THE MANUFACTURER CANNOT BE HELD RESPONSIBLE FOR ANY DAMAGE CAUSED BY IMPROPER, ERRONEOUS, OR UNACCEPTABLE USE.

2.1 Training of personnel

The machine may be operated only by suitably trained and authorized personnel.

Given the complexity of the operations necessary to manage the machine and to carry out the operations safely and efficiently, the personnel must be trained in such a way that they learn all the information necessary to operate the machine as intended by the manufacturer.



A CAREFUL READING OF THIS INSTRUCTION MANUAL FOR USE AND MAINTENANCE AND A SHORT PERIOD OF TRAINING WITH SKILLED PERSONNEL CAN BE AN ENOUGH PREVENTIVE PREPARATION.

3.0 SAFETY DEVICES



PERIODICALLY, AT LEAST MONTHLY, CHECK THE INTEGRITY AND THE FUNCTIONALITY OF THE SAFETY AND PROTECTION DEVICES ON THE MACHINE.

- **Main switch positioned on the rear of the machine**

Its function is to disconnect machine electric supply.

- **Protection guard**

Its function is to protect the operator from possible projections of materials on the wheel during its spin. Wheel spinning is normally prevented if the wheel protection guard is raised (open). When the protection guard is open, this interrupts the circuit that triggers the motor and automatic start is prevented, including in the case of an error.



Press  stop key to stop wheel rotation in emergency conditions.

- **Laser safety (in case the laser device is present)**



USE OF CONTROLS OR ADJUSTMENTS OR PERFORMANCE OF PROCEDURES OTHER THAN THOSE SPECIFIED HEREIN MAY RESULT IN HAZARDOUS RADIATION EXPOSURE.

3.1 Residual risks

The machine was subjected to a complete analysis of risks according to reference standard EN ISO 12100. Risks are as reduced as possible in relation with technology and product functionality.

Possible residual risks have been emphasized through pictorial representations and warnings which placing is indicated in " PLATE POSITIONING DRAWING" at page 8.

In case the laser device is present



THIS DEVICE IS EQUIPPED WITH SOFTWARE-CONTROLLED LASER EMITTERS.

WARNING AND INFORMATION PLATES HAVE BEEN APPLIED OUTSIDE THE DEVICE, IN ORDER TO INDICATE THE PRESENCE AND EMPLOYMENT OF LASER MEASURING INSTRUMENTS.

DO NOT STARE AT THE LASER EMITTERS DIRECTLY AT CLOSE RANGE WHILE THE EQUIPMENT IS OPERATING.



4.0 GENERAL SAFETY RULES



- Any tampering with or modification to the machine not previously authorized by the manufacturer exempts the latter from all responsibility for damage caused by or derived from said actions.
- Removing of or tampering with the safety devices or with the warning signals placed on the machine leads to serious dangers and represents a transgression of European safety rules.
- Use of the machine is only permitted in places free from **explosion** or **fire** hazard and in **dry places under cover**.
- Original spare parts and accessories should be used.



THE MANUFACTURER DENIES ANY RESPONSIBILITY IN CASE OF DAMAGES CAUSED BY UNAUTHORIZED MODIFICATIONS OR BY THE USE OF NON ORIGINAL COMPONENTS OR EQUIPMENT.

- The installation must be performed by qualified and authorized personnel in full compliance with the instructions given below.
- Ensure that there are no dangerous situations during the machine operating manoeuvres. Immediately stop the machine if it miss-functions and contact the assistance service of an authorized dealer.
- In emergency situations and before carrying out any maintenance or repairs, disconnect all supplies to the machine by using the main switch, placed on the machine itself, and unplugging the power supply.
- The machine power supply system must be equipped with an appropriate earthing, to which the yellow-green machine protection wire must be connected.
- Ensure that the work area around the machine is free of potentially dangerous objects and that there is no oil since this could damage the tyre. Oil on the floor is also a potential danger for the operator.
- **UNDER NO CIRCUMSTANCES** must the machine be used to spin anything but vehicle wheels. Bad locking can cause rotating parts to come loose, with potential damage to the machine and anything in the vicinity and injury to the operator.



OPERATORS MUST WEAR SUITABLE WORK CLOTHES, PROTECTIVE GLASSES AND GLOVES, AGAINST THE DANGER FROM THE SPRAYING OF DANGEROUS DUST, AND POSSIBLY LOWER BACK SUPPORTS FOR THE LIFTING OF HEAVY PARTS. DANGLING OBJECTS LIKE BRACELETS MUST NOT BE WORN, AND LONG HAIR MUST BE TIED UP. FOOTWEAR SHOULD BE ADEQUATE FOR THE TYPE OF OPERATIONS TO BE CARRIED OUT.



- The machine handles and operating grips must be kept clean and free from oil.
- The workshop must be kept clean and dry. Make sure that the working premises are properly lit. The machine can be operated by a single operator. Unauthorized personnel must remain outside the working area, as shown in **Fig. 3**. Avoid any hazardous situations. Do not use air-operated or electrical equipment when the shop is damp or the floor slippery and do not expose such tools to atmospheric agents.
- When operating and servicing this machine, carefully follow all applicable safety and accident-prevention precautions. The machine must not be operated by untrained personnel.



WHEN USING THE MODELS WITH WHEEL PNEUMATIC CLAMPING, DURING CHUCK OPENING/CLOSING OPERATIONS, BE EXTREMELY CAREFUL AND KEEP YOUR HANDS OR OTHER PARTS OF YOUR BODY AWAY FROM THE MOVING CHUCK.

5.0 PACKING AND MOBILIZATION FOR TRANSPORT



HAVE THE MACHINE HANDLED BY SKILLED PERSONNEL ONLY.

THE LIFTING EQUIPMENT MUST WITHSTAND A MINIMUM RATED LOAD EQUAL TO THE WEIGHT OF THE PACKED MACHINE (SEE PARAGRAPH "TECHNICAL SPECIFICATIONS").

The machine is packed partially assembled.
Movement must be by pallet-lift or fork-lift trolley.
The fork lifting points are indicated on the packing.

Fig. 2

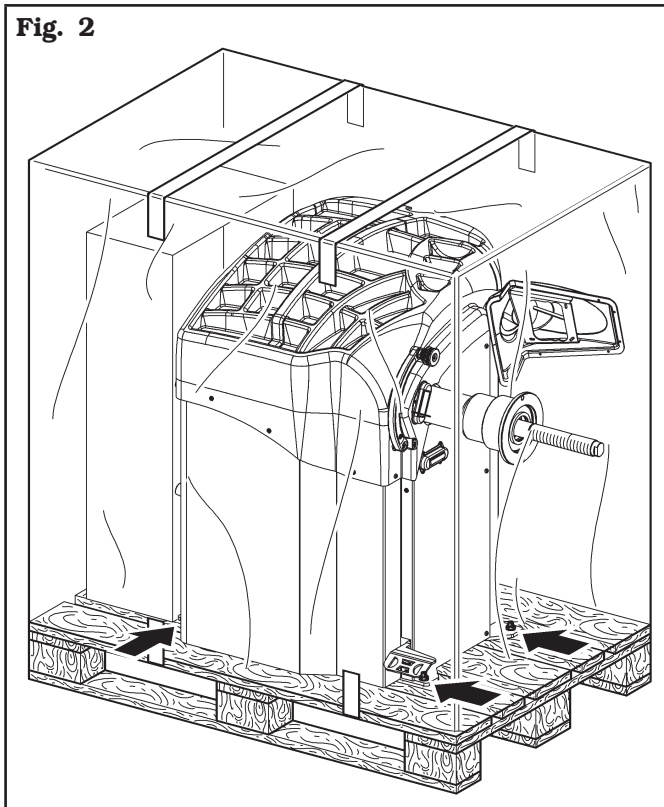

6.0 UNPACKING



DURING UNPACKING, ALWAYS WEAR GLOVES TO PREVENT ANY INJURY CAUSED BY CONTACT WITH PACKAGING MATERIAL (NAILS, ETC.).

The cardboard box is supported with plastic strapping. Cut the strapping with suitable scissors. Use a small knife to cut along the lateral axis of the box and open it like a fan.

It is also possible to unnailed the cardboard box from the pallet it is fixed to. After removing the packing, and in the case of the machine packed fully assembled, check that the machine is complete and that there is no visible damage.

If in doubt **do not use the machine** and refer to professionally qualified personnel (to the seller).

The packing (plastic bags, expanded polystyrene, nails, screws, timber, etc.) should not be left within reach of children since it is potentially dangerous. These materials should be deposited in the relevant collection points if they are pollutants or non biodegradable.



THE BOX CONTAINING THE FIXTURES IS CONTAINED IN THE WRAPPING. DO NOT THROW IT AWAY WITH THE PACKING.



7.0 MOBILIZATION



THE LIFTING EQUIPMENT MUST WITHSTAND A MINIMUM RATED LOAD EQUAL TO THE WEIGHT OF THE MACHINE (SEE PARAGRAPH TECHNICAL SPECIFICATIONS). DO NOT ALLOW THE LIFTED MACHINE TO SWING.



NEVER LIFT THE MACHINE BY MEANS OF THE CHUCK.

If the machine has to be moved from its normal work post, the movement must be conducted following the instructions listed below.

- Protect the exposed corners with suitable material (Pluribol/cardboard).
- Do not use metallic cables for lifting.
- Make sure the power and pneumatic supply (on models with pneumatic chuck) of the machine are not connected.
- Place again the machine onto the original pallet with whom it was delivered.
- Use transpallet or fork-lift for handling.

8.0 WORKING ENVIRONMENT CONDITIONS

The machine must be operated under proper conditions as follows:

- temperature: 0° + 45° C
- relative humidity: 30 - 90% (dew-free)
- atmospheric pressure: 860 - 1060 hPa (mbar).

The use of the machine in ambient conditions other than those specified above is only allowed after prior agreement with and approval of the manufacturer.

8.1 Working area

Fig. 3

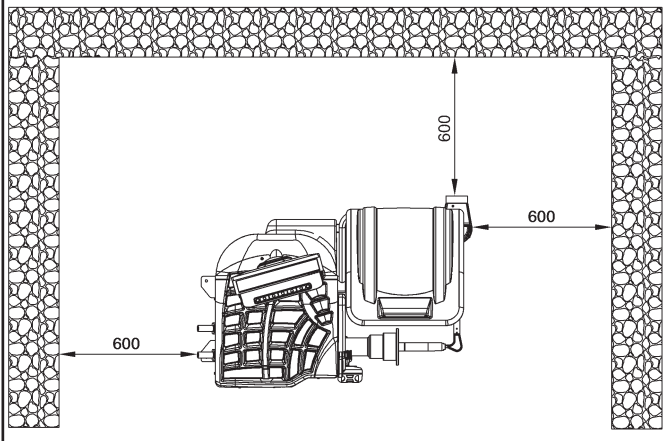

USE THE MACHINE IN A DRY AND ADEQUATELY LIT PLACE, POSSIBLY INDOORS OR ANYWAY IN A ROOFED AREA, THIS PLACE MUST BE IN COMPLIANCE WITH APPLICABLE SAFETY REGULATIONS.

The location of the machine requires a usable space as indicated in **Fig. 3**. The positioning of the machine must be according to the distances shown. From the control position the operator is able to observe all the machine and surrounding area. He must prevent unauthorized personnel or objects that could be dangerous from entering the area.

The machine must be fixed on a flat floor surface, preferably of cement or tiled. Avoid yielding or irregular surfaces.

The base floor must be able to support the loads transmitted during operation.

This surface must have a capacity load of at least 500 kg/m².

The depth of the solid floor must be sufficient to guarantee that the anchoring bolts hold.

8.2 Lighting

The machine does not require its own lighting for normal working operations. However, it must be used in an adequately lit environment.

In case of poor lighting use lamps having total power of 800/1200 Watt.



IF IT IS INSTALLED, EACH TIME THE ROD OF THE GAUGE IS EXTRACTED FROM ITS HOUSING, THE LED LIGHT (FIG. 1 REF. 9) TURNS ON MAKING THE INSIDE OF THE WHEEL WHERE THE OPERATOR MUST WORK BRIGHTER.

9.0 MACHINE ASSEMBLY



EACH MECHANICAL INTERVENTION MUST BE CARRIED OUT BY PROFESSIONALLY QUALIFIED STAFF.

After having freed the various components from the packing check that they are complete, and that there are no anomalies, then comply with the following instructions for the assembly of the components making use of the attached series of illustrations.

9.1 Anchoring system

The packed machine is fixed to the support pallet through the holes prearranged on the frame. Such holes can be used also to fix the machine to the ground, through floor anchor small blocks (excluded from supply). Before carrying out the definitive fixing, check that all the anchor points are laid down flat and correctly in contact with the fixing surface itself. If not so, insert shimming profiles between the machine and the fixing lower surface, as indicated in **Fig. 4**.



IN CASE OF WHEEL WEIGHING MORE THAN 30 KG, IT IS COMPULSORY TO FIX TO THE GROUND BY MEANS OF SCREW ANCHORS.

Fig. 4

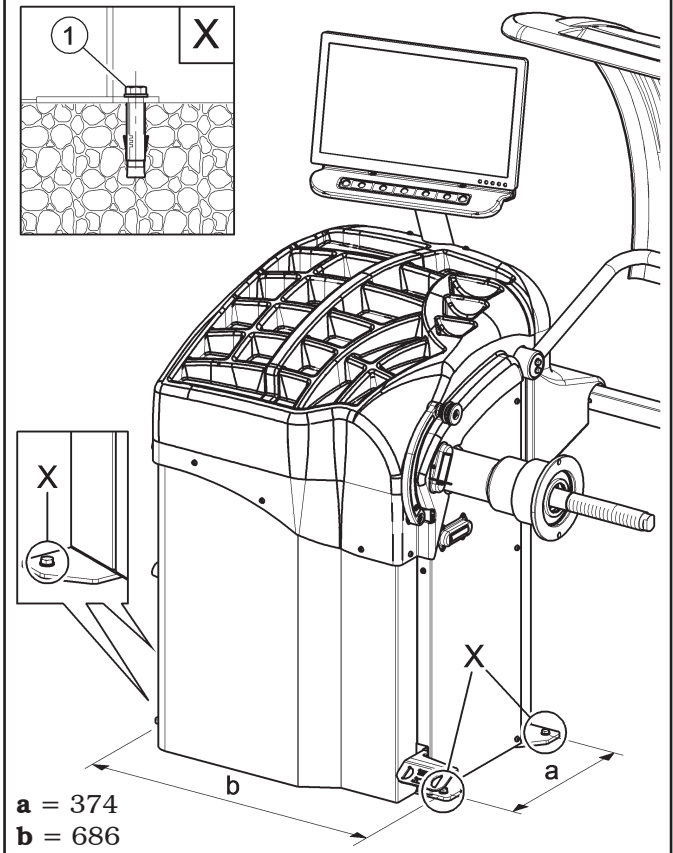

- Execute 4 holes with 10 mm diameter on the floor by the holes on the bottom floor;
- insert the small blocks (excluded from supply) into the holes;
- fix the machine to the ground with 4 M8x80 mm screws (excluded from supply) (**Fig. 4 ref. 1**) (or with 4 8x80 mm stud bolts (excluded from supply)). Tighten the screws with an approximate tightening torque of 70 Nm.

9.2 Assembly procedures

9.2.1 Fitting the chuck on the flange

For models with threaded chuck

Screw the chuck with an Allen wrench (**Fig. 5 ref. 1**) on the flange (**Fig. 5 ref. 2**).

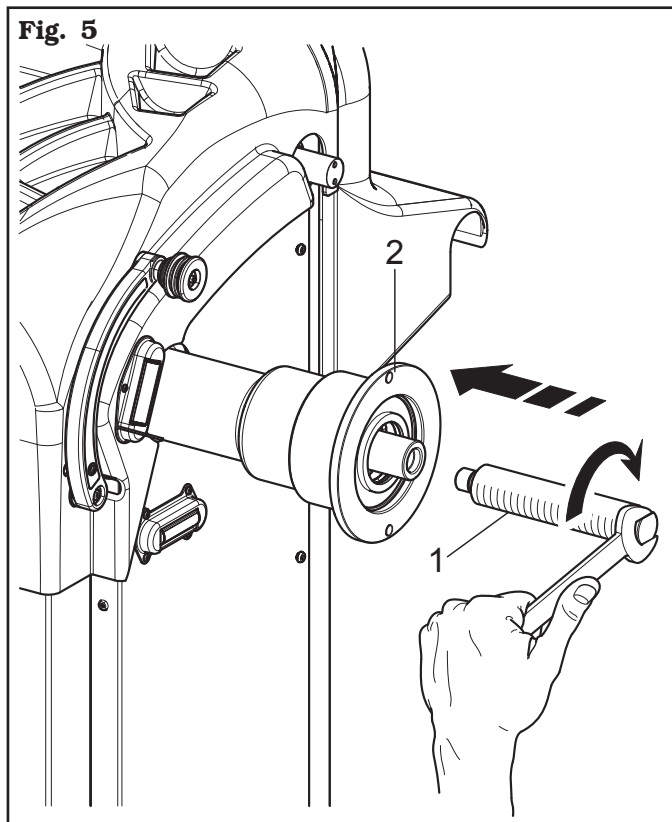

9.2.2 Fitting and removal of the pneumatic chuck on the flange

On model with pneumatic chuck

FITTING

1. After making power and air connections switch on the machine (the pneumatic chuck always opens when the machine is switched on).
2. Switch the machine off by using the main switch (**Fig. 30 ref. 1**). Couple tyre inner rod (**Fig. 6 ref. 1**) with flange inner rod (**Fig. 6 ref. 2**) (see **Fig. 6**).

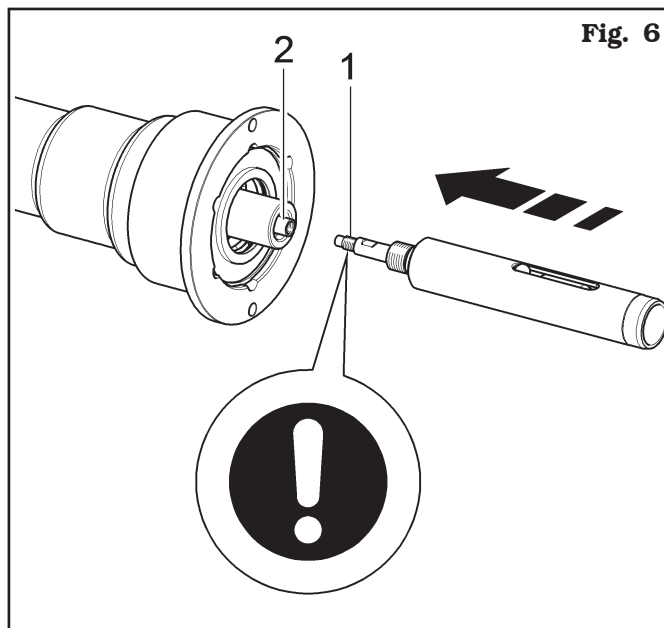

FOR PNEUMATIC SHAFT KIT FITTING (FIG. 6 REF. 1) USE MEDIUM RESISTANCE LOCTITE 242 THREADLOCKERS OR EQUIVALENT ONLY ON M10 THREAD AND TIGHTEN TO 30NM.

3. Tighten tyre inner rod (**Fig. 7 ref. 1**) with flange inner rod (**Fig. 7 ref. 2**) by using the wrench provided (**Fig. 7 ref. 3**) and a 12 mm wrench (**Fig. 7 ref. 4**). Use also a torque spanner (**Fig. 7 ref. 5**) (not supplied) on one of the 2 holes on the provided spanner (**Fig. 7 ref. 3**).

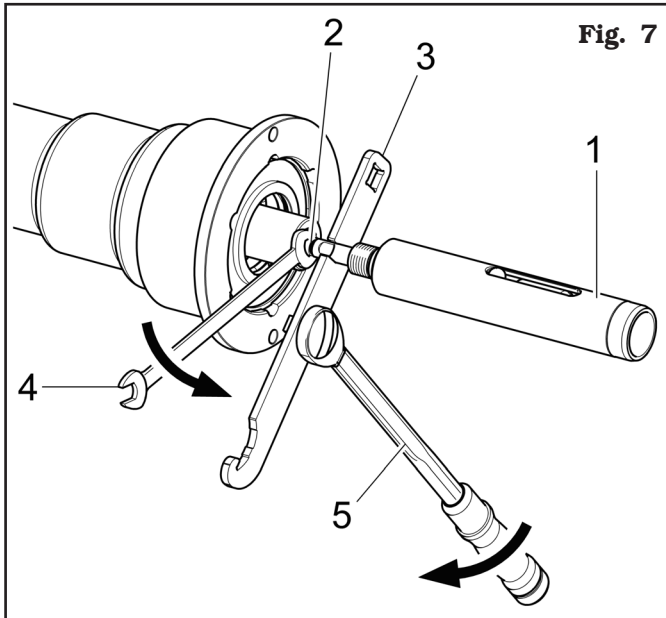

4. Lock the chuck by pressing the brake and turn the pneumatic shaft screw (**Fig. 8 ref. 1**) onto the flange (**Fig. 8 ref. 2**) until it stops.

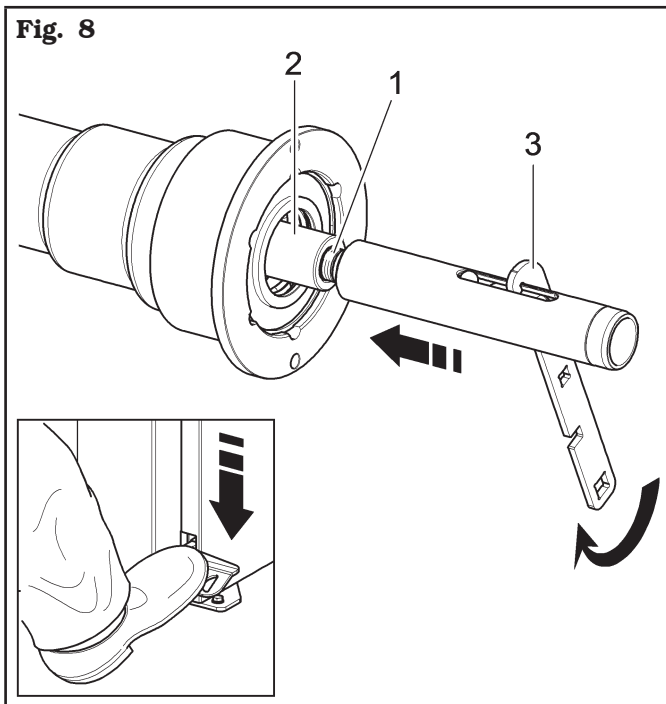

5. Tighten with the wrench provided (**Fig. 8 ref. 3**).

REMOVAL

1. Open the pneumatic chuck by means of the pedal provided and make sure the outer ball (**Fig. 9 ref. 1**) is in the position indicated in **Fig. 9**.

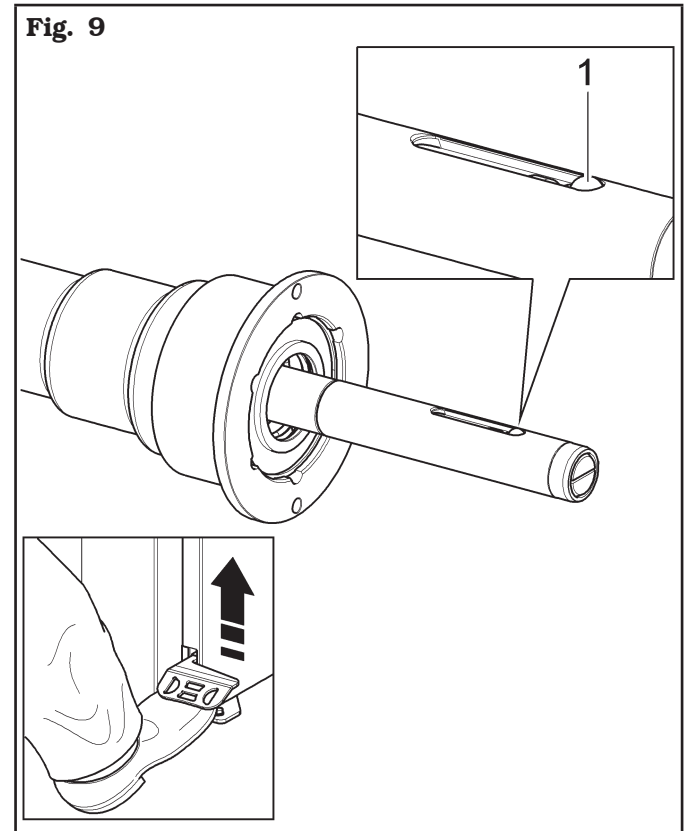

2. Lock the chuck by pressing the brake and unlock the pneumatic shaft (**Fig. 10 ref. 1**) using the wrench provided (**Fig. 10 ref. 2**).

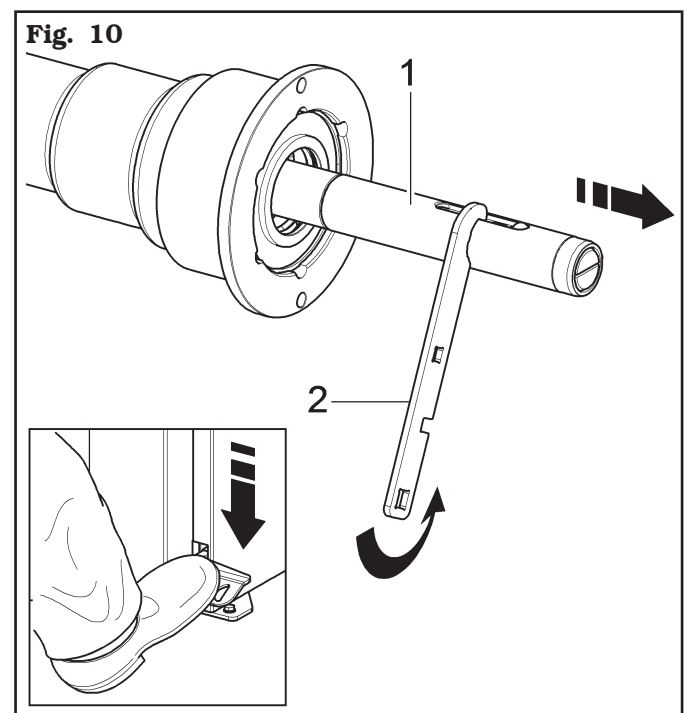

3. Unscrew pneumatic shaft screw (**Fig. 11 ref. 1**) and release the two inner rods with the special wrench provided (**Fig. 11 ref. 2**) and a 12 mm wrench (**Fig. 11 ref. 3**).

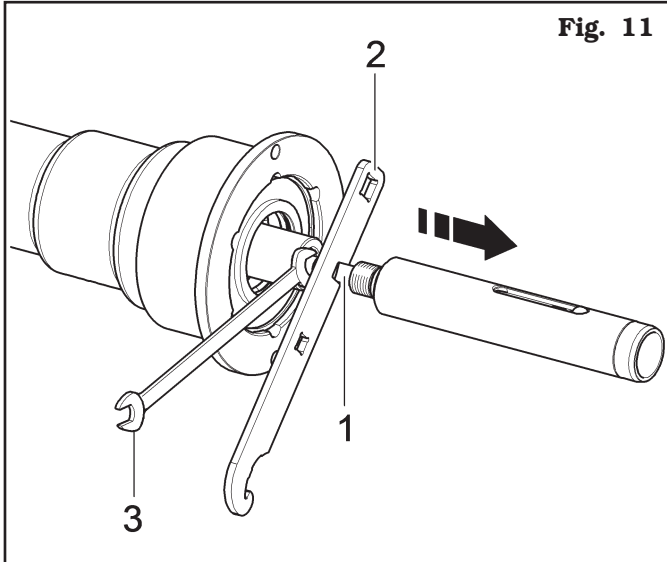
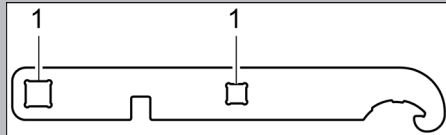

Fig. 11

IT THE TORQUE SPANNER INTO THE PROVIDED HOLES (REF. 1) OF THE SUPPLIED SPANNER AND TIGHTEN TO 30 NM.



9.2.3 Monitor fitting

1. Unscrew the nuts (**Fig. 12 ref. 1**) and the washers (**Fig. 12 ref. 2**) from the screws (**Fig. 12 ref. 3**). Fit the support tube (**Fig. 12 ref. 4**) rotated through 90°. Then screw the previously unscrewed nuts and washers again.

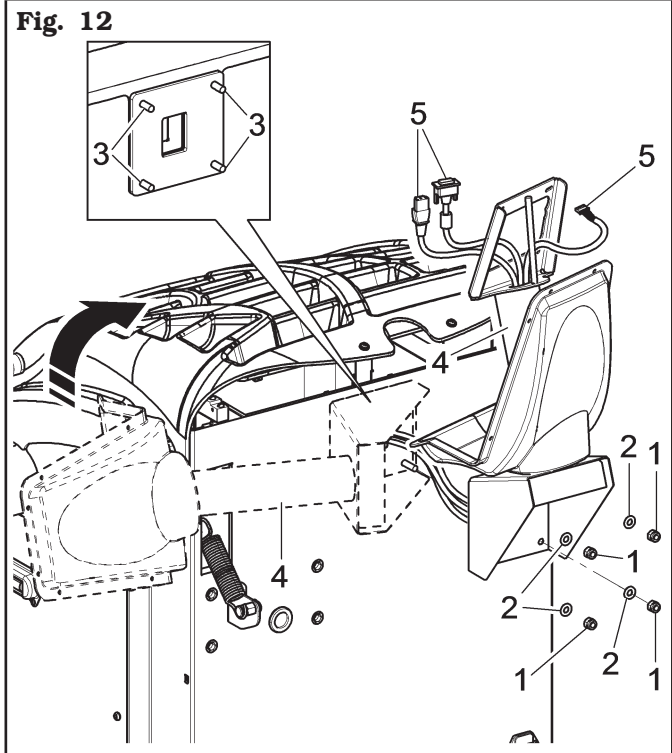

Fig. 12



DURING THIS OPERATION, PAY PARTICULAR ATTENTION TO THE POWER SUPPLY CABLE, TO THE HDMI CABLE AND TO THE KEYBOARD CABLES (FIG. 12 REF. 5) IN ORDER NOT TO DAMAGE THEM. MAKE SURE THEY HAVE BEEN INTRODUCED IN THE SUPPORT PIPE, AS SHOWN IN FIG. 12.

2. Fix the bracket (**Fig. 13 ref. 1**) to the support tube (**Fig. 13 ref. 2**) with the screws (**Fig. 13 ref. 3**) and the washers (**Fig. 13 ref. 4**) supplied. Fix the keyboard (**Fig. 13 ref. 5**) to the bracket (**Fig. 13 ref. 1**) using the screws supplied (**Fig. 13 ref. 6**). Fix the monitor (**Fig. 13 ref. 7**) the bracket (**Fig. 13 ref. 1**) and to the support (**Fig. 13 ref. 2**) by means of the supplied screws (**Fig. 13 ref. 8**) and (**Fig. 13 ref. 9**).

Fig. 13

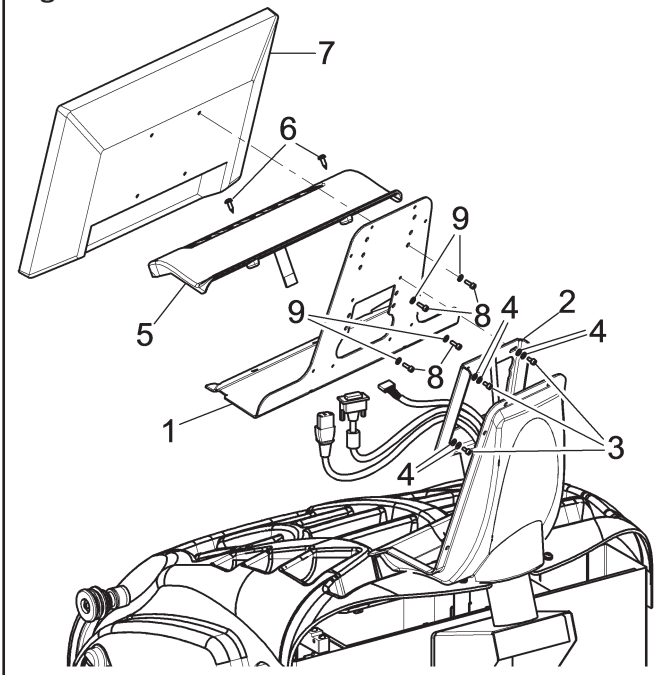

3. Connect the plugs on the power supply sockets and monitor signal. Connect the wiring of the keyboard.
4. Fix the guard (**Fig. 14 ref. 1**) to the support (**Fig. 14 ref. 2**) with the screws (**Fig. 14 ref. 3**) and the washers (**Fig. 14 ref. 4**) supplied.

Fig. 14

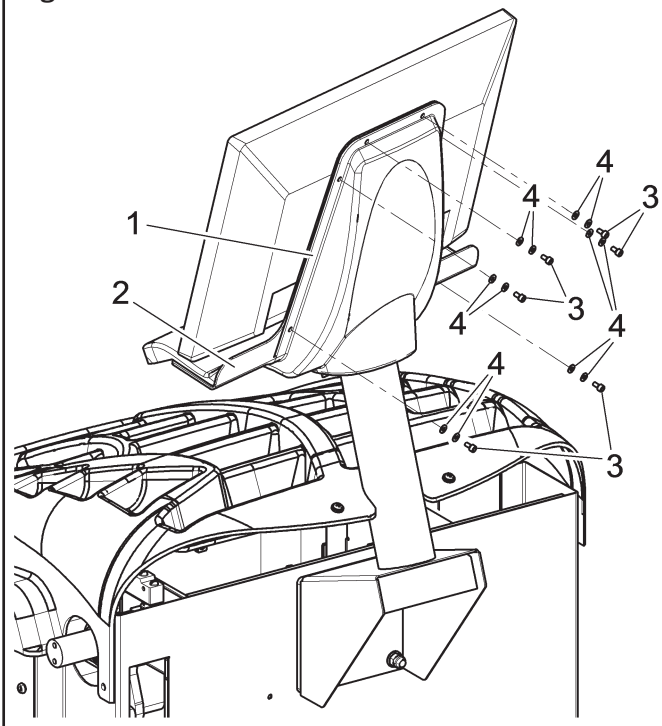

9.2.4 Touch-screen monitor fitting (optional)

1. Unscrew the nuts (**Fig. 15 ref. 1**) and the washers (**Fig. 15 ref. 2**) from the screws (**Fig. 15 ref. 3**). Fit the monitor support (**Fig. 15 ref. 4**) rotated through 90°. Then screw the previously unscrewed nuts and washers again.
2. Make the cables (**Fig. 15 ref. 5**) pass into the plate's hole (**Fig. 15 ref. 6**) and fix the latter to the monitor support (**Fig. 15 ref. 4**) by means of the supplied screws (**Fig. 15 ref. 7**) and washers (**Fig. 15 ref. 8**).

Fig. 15

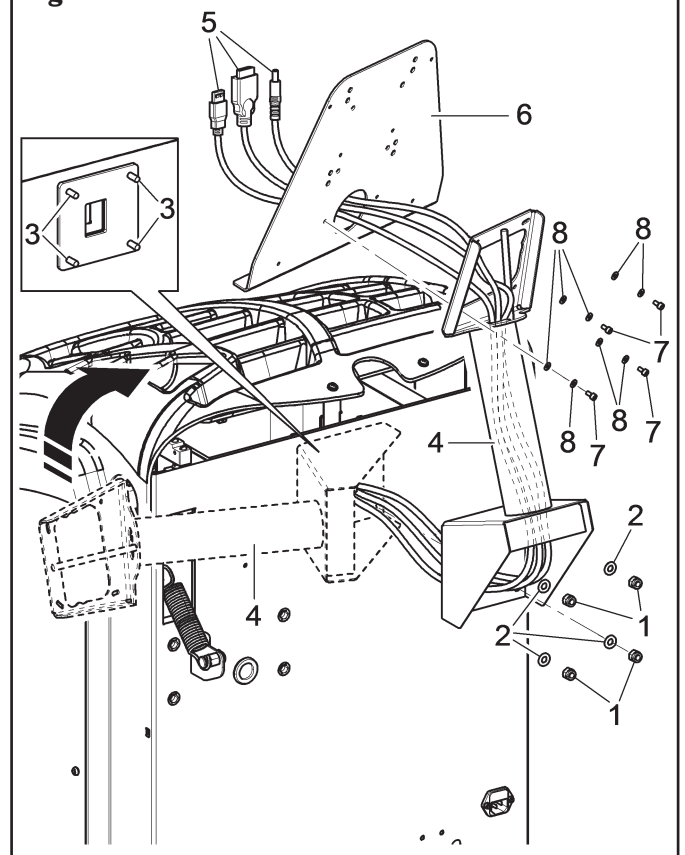

DURING THIS OPERATION PAY PARTICULAR ATTENTION TO THE POWER SUPPLY CABLE, TO THE HDMI CABLE AND TO THE USB CABLE (FIG. 15 REF. 5) IN ORDER NOT TO DAMAGE THEM. MAKE SURE THEY HAVE BEEN INTRODUCED IN THE SUPPORT PIPE, AS SHOWN IN FIG. 15.

3. Connect the cables to the monitor **Fig. 16 ref. 1**), as shown in **Fig. 16** (USB cable **ref. 2**, HDMI cable **ref. 3**, power supply cable **ref. 4**). Fix the monitor (**Fig. 16 ref. 1**) to the plate (**Fig. 16 ref. 5**) with the screws (**Fig. 16 ref. 6**) and the washers (**Fig. 16 ref. 7**) supplied.

Fig. 16

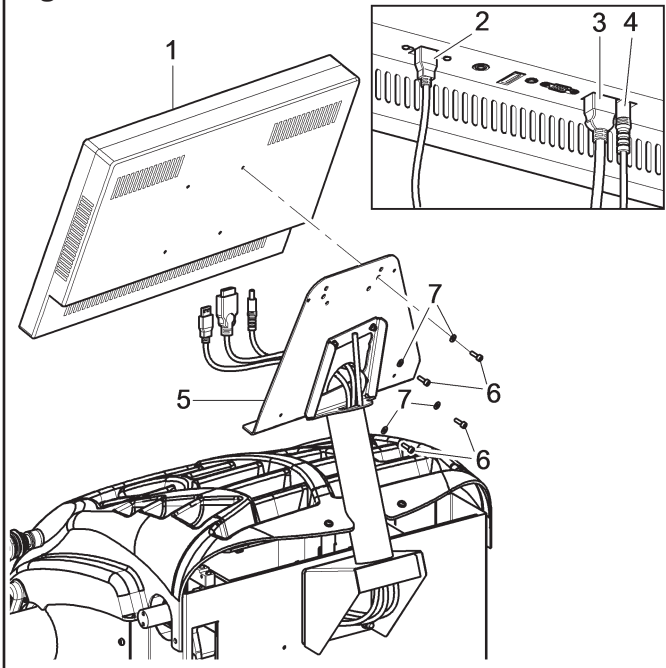

DURING THIS OPERATION PAY PARTICULAR ATTENTION TO (POWER SUPPLY/SIGNAL/USB) CABLES CONNECTIONS TO THE MONITOR, IN ORDER NOT TO DAMAGE THEM AND TO ENSURE PRODUCT'S CORRECT OPERATION.

4. Fix the guard (**Fig. 17 ref. 1**) to the monitor support (**Fig. 17 ref. 2**) with the screws (**Fig. 17 ref. 3**) and the washers (**Fig. 17 ref. 4**) supplied.

Fig. 17

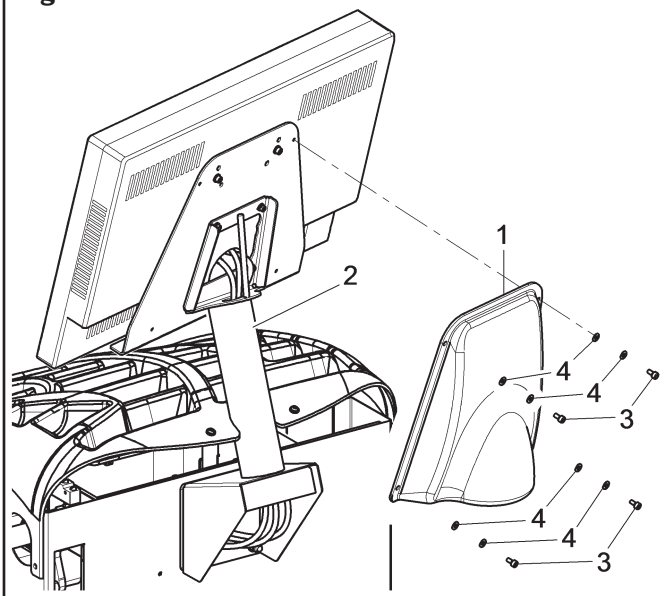

9.2.5 Fitting the protection guard

1. Mount the protection guard (**Fig. 18 ref. 1**) to the support (**Fig. 18 ref. 2**) using the screws (**Fig. 18 ref. 3**), interposing the Belleville washers (**Fig. 18 ref. 4**) and the tab washers (**Fig. 18 ref. 5 - 6**).
2. Tighten the screws (**Fig. 18 ref. 3**) in order to make the guard (**Fig. 18 ref. 1**) lift or lower without bumping against the limit switch. Carry out the adjustment so that it's possible to manually guide the guard both during closing and opening.



DURING GUARD ASSEMBLY, PAY ATTENTION TO THE MICRO PLACED INSIDE THE MACHINE.

Standard on some models

3. Connect the ultrasound sensor cable (**Fig. 18 ref. 7**) of the automatic width measuring device (**Fig. 19 ref. 9**) to the provided connector (**Fig. 18 ref. 8**).
4. At the end of the connection, introduce the connectors in wheel cover slot (**Fig. 18 ref. 10**), as illustrated in **Fig. 18**. Eventually, fasten connector's cable (**Fig. 18 ref. 8**) with a clamp (**Fig. 18 ref. 11**).

Fig. 18

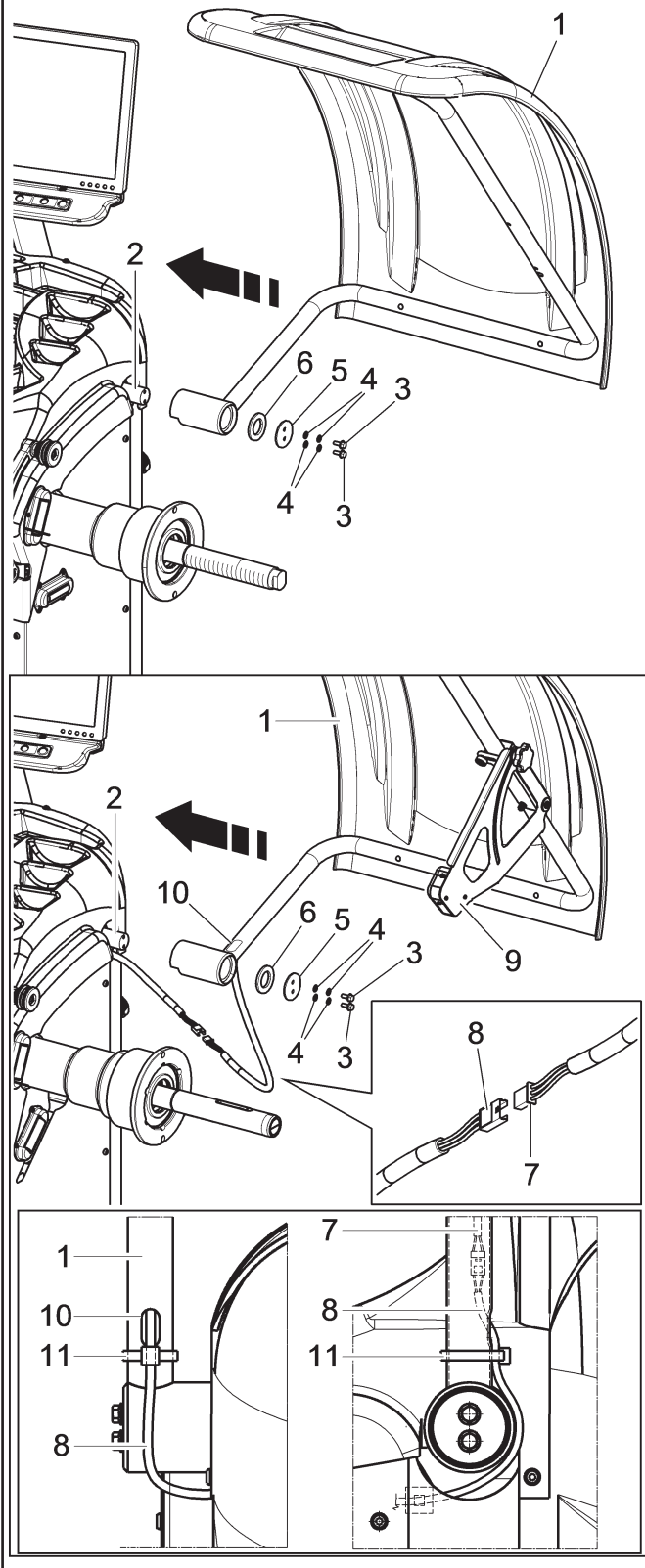

**9.2.6 Fitting of wheel external data gauge
(standard on some models)**

1. Insert the 4 screws (**Fig. 19 ref. 1**) in the gauge bracket (**Fig. 19 ref. 2**) and screw them on the threaded rivets placed on the rear side of the frame. Lock the gauge arm (**Fig. 19 ref. 3**) to the bracket (**Fig. 19 ref. 2**) using the 2 screws (**Fig. 19 ref. 4**) and the washers (**Fig. 19 ref. 5**). Lock the screws (**Fig. 19 ref. 4**) with the washers (**Fig. 19 ref. 5**) and the nuts (**Fig. 19 ref. 6**) so that the shaft and the gauge arm are levelled out (see **Fig. 20**).

Fig. 19

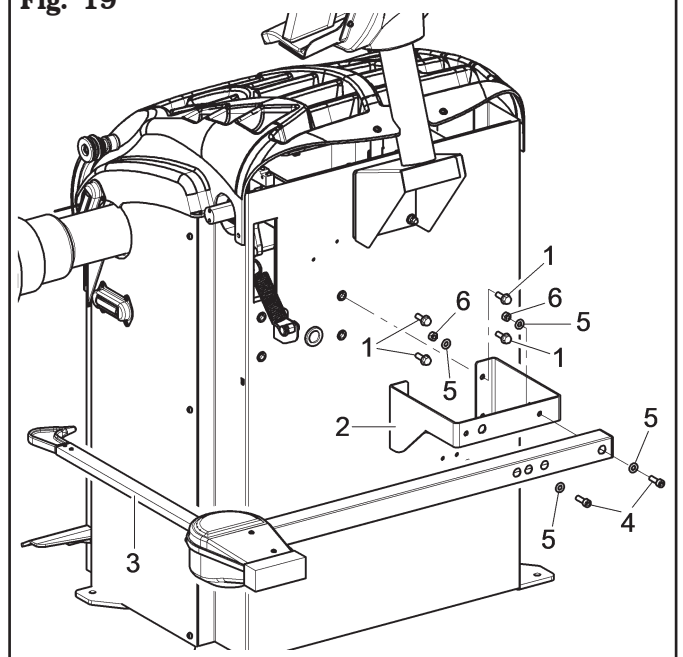

2. Also make sure the gauge tip (**Fig. 20 ref. 1**) is positioned at the centre of the chuck.

Fig. 20

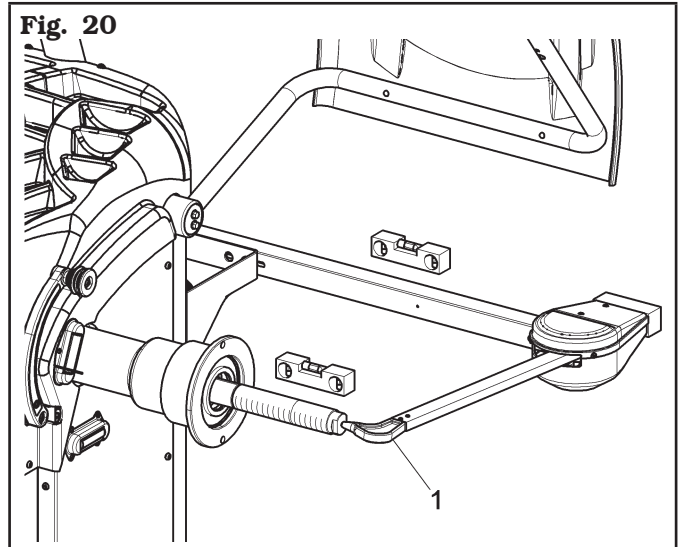

3. Connect connector (**Fig. 21 ref. 1**) of the cable coming from inside the machine to connector (**Fig. 21 ref. 2**) of the cable coming from the gauge arm. Fit the section of the cable with the connectors inside the arm (**Fig. 21 ref. 3**).
4. Fasten the cable with clamps.
5. Enable the external data gauge and carry out the device calibration.

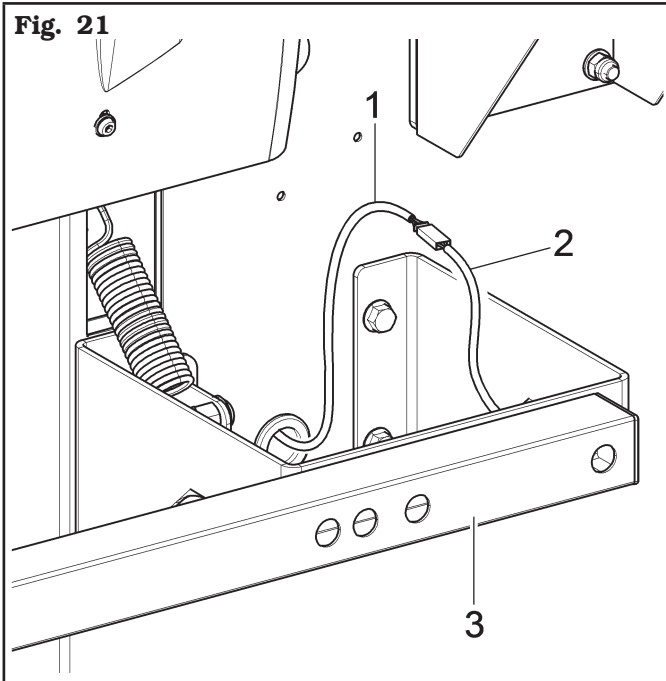

6. Mount machine rear covering (**Fig. 22 ref. 1**) using the screws (**Fig. 22 ref. 2**) and washers (**Fig. 22 ref. 3**), supplied.

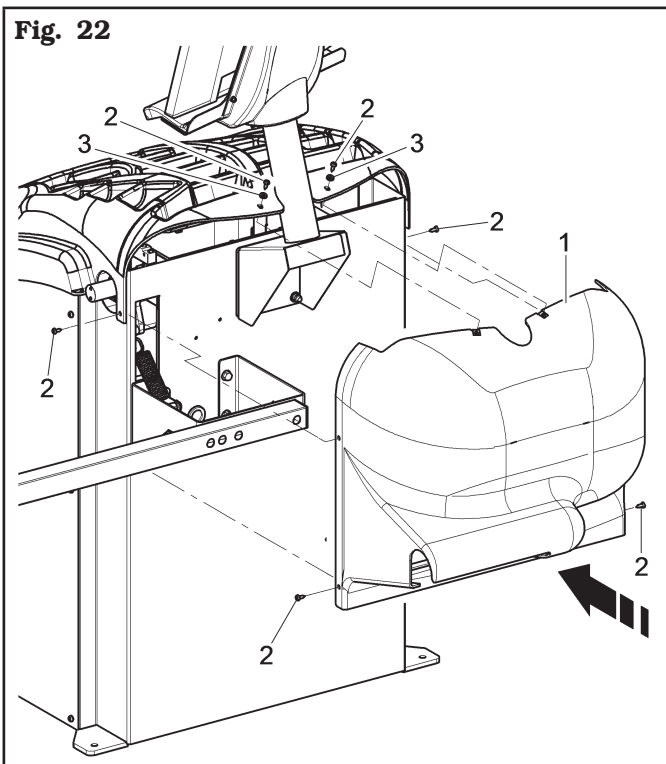

9.2.7 Fitting of external data gauge / Run-out (optional on some models)

1. Remove the rear covering (**Fig. 23 ref. 1**) from the machine.
2. Introduce the 4 screws (**Fig. 23 ref. 2**) to the gauge bracket (**Fig. 23 ref. 3**) and screw them to the threaded rivets placed on the rear side of the frame. Insert arm stiffener (**Fig. 23 ref. 4**) into the gauge arm (**Fig. 23 ref. 5**) and fix them to the bracket (**Fig. 23 ref. 3**) using 2 screws (**Fig. 23 ref. 6**) and the washers (**Fig. 23 ref. 7**). Lock the screws (**Fig. 23 ref. 6**) with the nuts (**Fig. 23 ref. 8**) so that the shaft and the gauge arm are levelled out (see **Fig. 24**).

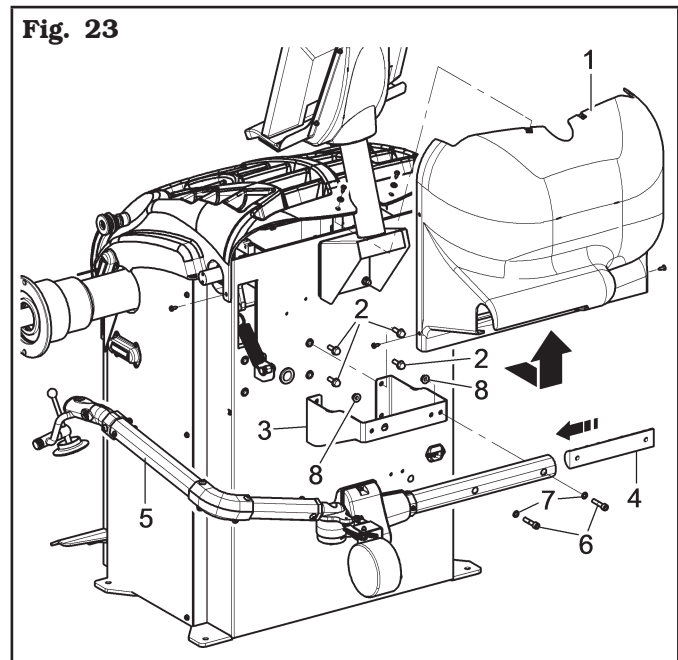

3. Also make sure the gauge tip (**Fig. 24 ref. 1**) is positioned at the centre of the chuck.

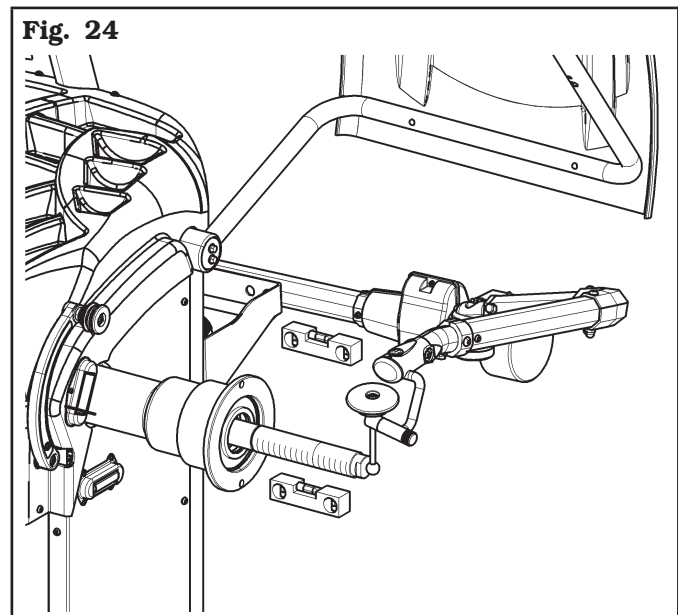

4. Connect connector (**Fig. 25 ref. 1**) of the cable coming from inside the machine to connector (**Fig. 25 ref. 2**) of the cable coming from the gauge arm. Fit the section of the cable with the connectors inside the arm (**Fig. 25 ref. 3**).
5. Fasten the cable with clamps.
6. Enable the external data gauge and carry out the device calibration.

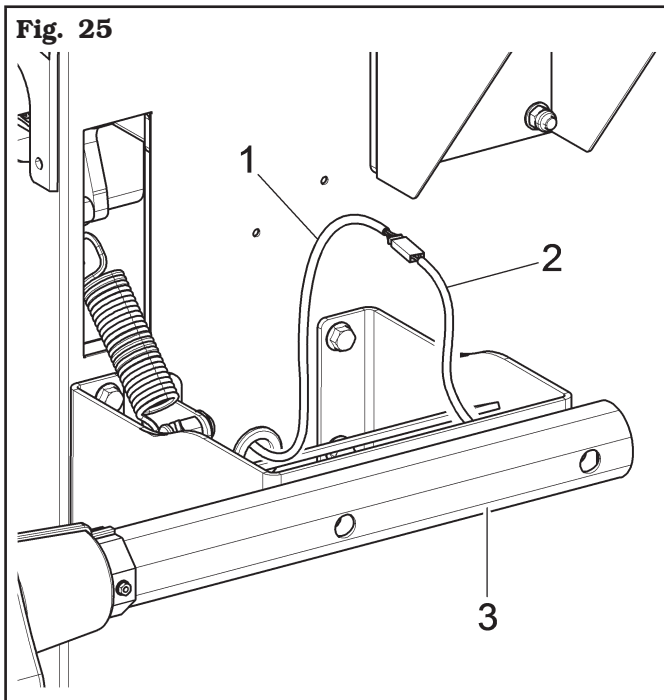

7. Mount the rear covering (**Fig. 23 ref. 1**) of the machine again.

9.2.8 Fitting of ultrasound Run-out (stand- ard on some models)

1. Fit the ultrasound sensor support plate (**Fig. 26 ref. 1**) to the bracket (**Fig. 26 ref. 2**) using the screws (**Fig. 26 ref. 3**), the washers (**Fig. 26 ref. 4**) and the nuts (**Fig. 26 ref. 5**).

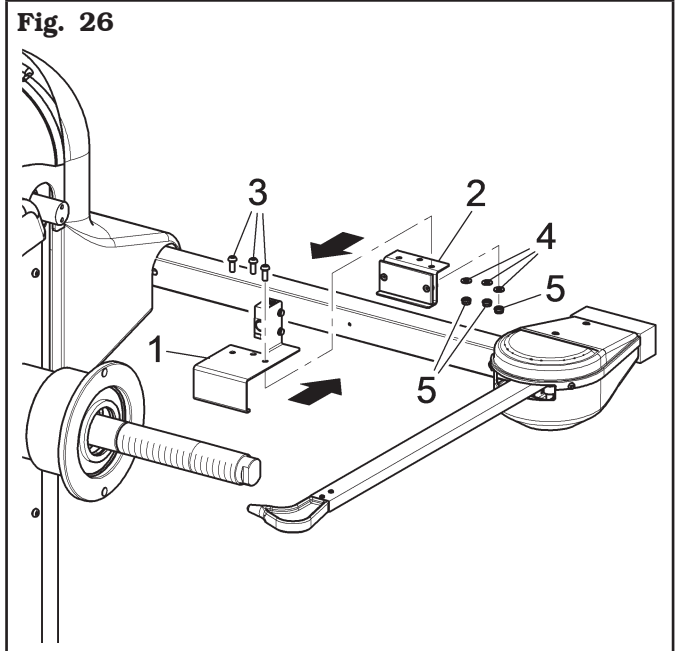

2. Demount wheel balancer bridge.

3. Mount the card (**Fig. 27 ref. 2**), as shown in **Fig. 27**.
4. Connect ultrasound Run-out cable plug (**Fig. 27 ref. 1**) to the electronic card (**Fig. 27 ref. 2**), as shown in **Fig. 27** (blue **ref. 4 cable**, brown **ref. 5 cable and black ref. 6 cable**). Connect the ultrasound Run-out card (**Fig. 27 ref. 2**) to the wheel balancer main card, using the provided cable JP18 (**Fig. 27 ref. 3**). Carry out the connection as shown in **Fig. 27**.

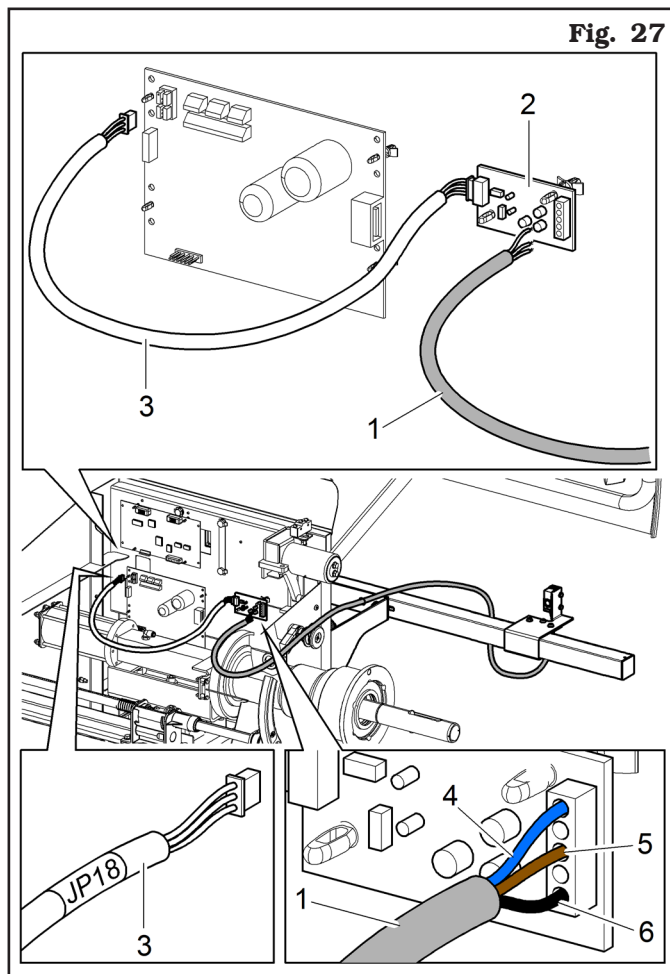

5. Fix the cables with clamps not to let them hinder the ordinary operation of the machine.
6. Mount wheel balancer protection guard again.



FOR THE CONNECTIONS, REFER TO WIRING DIAGRAMS.

9.2.9 Fitting of ultrasound Run-out with support (standard on some models)

1. Remove the rear covering (**Fig. 28 ref. 1**) from the machine.
2. Introduce the 4 screws (**Fig. 28 ref. 2**) to the gauge bracket (**Fig. 28 ref. 3**) and screw them to the threaded rivets placed on the rear side of the frame. Lock the Run-out ultrasound arm (**Fig. 28 ref. 4**) to the bracket (**Fig. 28 ref. 3**) using the 2 screws (**Fig. 28 ref. 5**) and the washers (**Fig. 28 ref. 6**). Lock the screws (**Fig. 28 ref. 5**) screwing the provided nuts (**Fig. 28 ref. 7**) and washers (**Fig. 28 ref. 6**).
3. Mount the ultrasounds Run-out (**Fig. 28 ref. 8**) as illustrated in **Fig. 28**.

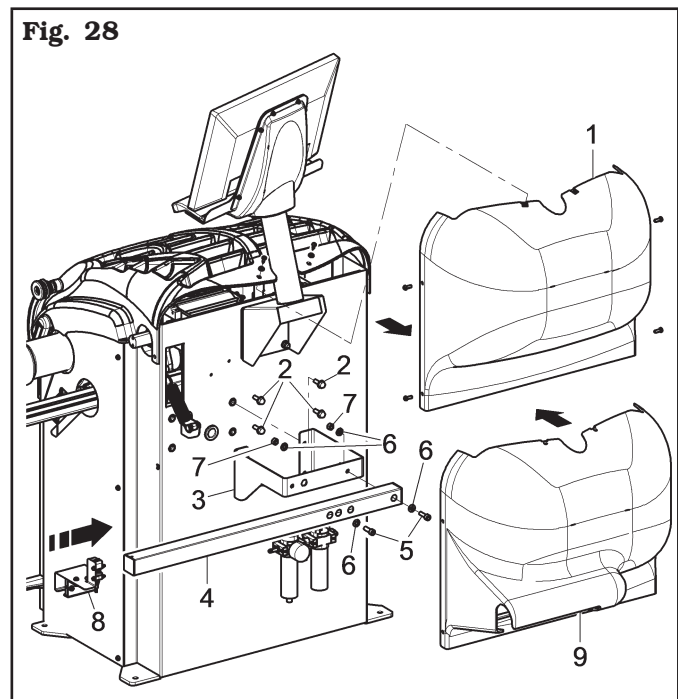

4. Demount wheel balancer bridge.

5. Mount the card (**Fig. 29 ref. 2**), as shown in **Fig. 29**.
6. Connect ultrasound Run-out cable plug (**Fig. 29 ref. 1**) to the electronic card (**Fig. 29 ref. 2**), as shown in **Fig. 29** (blue **ref. 4 cable**, brown **ref. 5 cable** and black **ref. 6 cable**). Connect the ultrasound Run-out card (**Fig. 29 ref. 2**) to the wheel balancer main card, using the provided cable JP18 (**Fig. 29 ref. 3**). Carry out the connection as shown in **Fig. 29**.

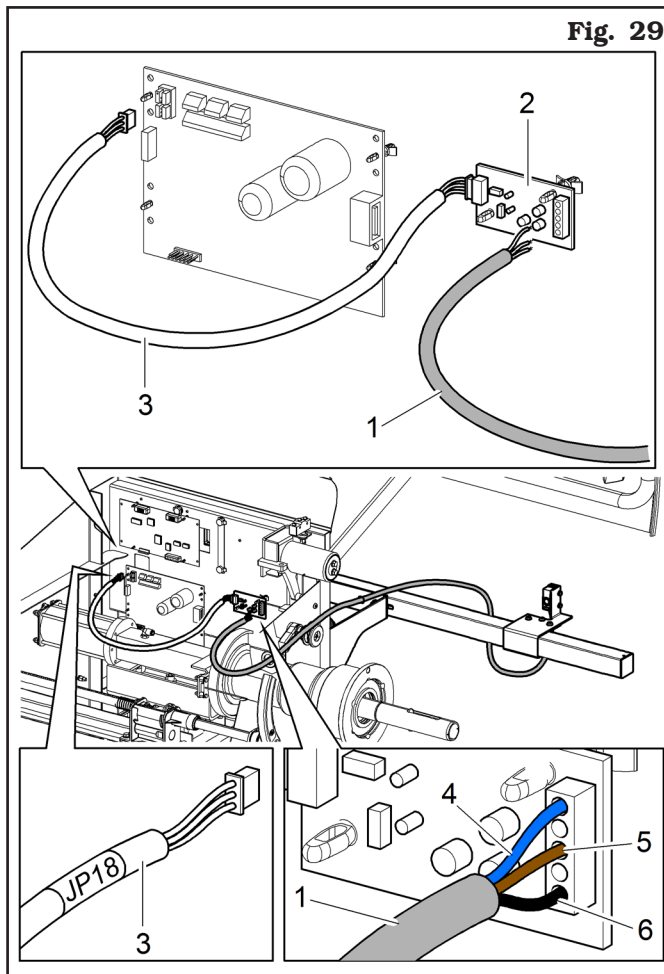

7. Fix the cables with clamps not to let them hinder the ordinary operation of the machine.
8. Fit the rear covering (**Fig. 28 ref. 9**).



FOR THE CONNECTIONS, REFER TO WIRING DIAGRAMS.

10.0 ELECTRICAL CONNECTIONS



EVEN THE TINIEST PROCEDURE OF AN ELECTRICAL NATURE MUST BE CARRIED OUT BY PROFESSIONALLY QUALIFIED STAFF.



BEFORE CONNECTING THE MACHINE MAKE SURE THAT:

- **POWER LINE SPECIFICATIONS CORRESPOND TO MACHINE REQUIREMENTS AS SHOWN ON THE MACHINE PLATE;**
- **ALL MAIN POWER COMPONENTS ARE IN GOOD CONDITION;**
- **THE ELECTRICAL SYSTEM IS PROPERLY GROUNDED (GROUND WIRE MUST BE THE SAME CROSS-SECTION AREA AS THE LARGEST POWER SUPPLY CABLES OR GREATER);**
- **MAKE SURE THAT THE ELECTRICAL SYSTEM FEATURES A CUTOUT WITH DIFFERENTIAL PROTECTION SET AT 30 mA.**

Connect the machine up to the mains by means of the 3-pole plug provided (230 V 1-phase).

If the plug provided is not suitable for the wall socket, fit a plug that complies with local and applicable regulations. This operation must be performed by expert and professional personnel.



FIT A TYPE-APPROVED (AS REPORTED BEFORE) PLUG TO THE MACHINE CABLE (THE GROUND WIRE IS YELLOW/GREEN AND MUST NEVER BE CONNECTED TO ONE OF THE TWO PHASE LEADS).



MAKE SURE THAT THE ELECTRICAL SYSTEM IS COMPATIBLE WITH THE RATED POWER ABSORPTION SPECIFIED IN THIS MANUAL AND APT TO ENSURE THAT VOLTAGE DROP UNDER FULL LOAD WILL NOT EXCEED 4% OF RATED VOLTAGE (10% UPON START-UP).



FAILURE TO OBSERVE THE ABOVE INSTRUCTIONS WILL IMMEDIATELY INVALIDATE THE WARRANTY.

10.1 Electrical checks



BEFORE STARTING UP THE WHEEL-BALANCER, BE SURE TO BECOME FAMILIAR WITH THE LOCATION AND OPERATION OF ALL CONTROLS AND CHECK THEIR PROPER OPERATION (SEE PAR. "CONTROLS").



CARRY OUT A DAILY CHECK OF THE MAINTAINED ACTION CONTROLS CORRECT FUNCTIONING, BEFORE STARTING MACHINE OPERATION.

Once the plug/socket connection has been made, turn on the machine using the main switch (**Fig. 30 ref. 1**).

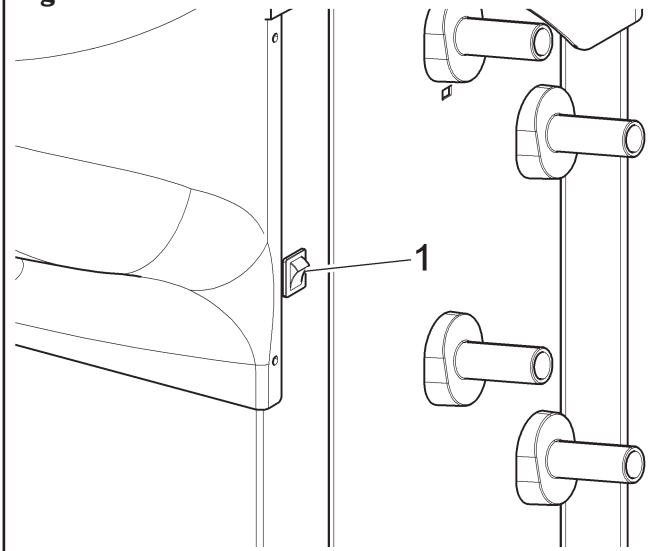
Fig. 30

11.0 AIR CONNECTION

On models with pneumatic chuck



EACH PNEUMATIC INTERVENTION MUST BE CARRIED OUT BY PROFESSIONALLY QUALIFIED STAFF.



IN CASE OF A CHANCE SUPPLY FAILURE, AND/OR BEFORE ANY PNEUMATIC CONNECTIONS, MOVE THE CONTROLS TO THE NEUTRAL POSITION.

Connect the wheel balancer to the centralised compressed-air system by means of the connection on the back of the machine (see **Fig. 31**).

The air system supplying the machine must be able to supply filtered and de-humidified air at a pressure between 8 and 10 bar. It must feature an on-off valve upstream of the machine.

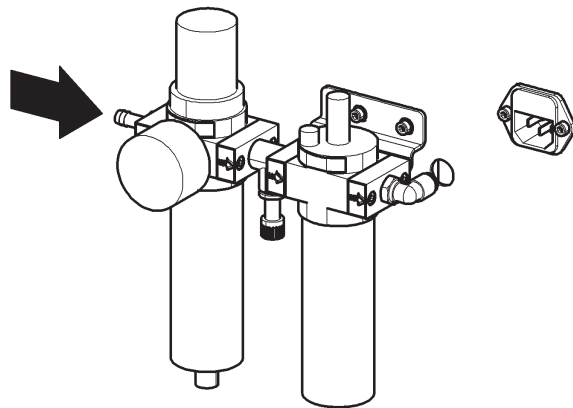
Fig. 31

12.0 FITTING THE WHEEL ON THE CHUCK



To achieve perfect balancing, the wheel must be carefully and properly fitted on the chuck. Imperfect centring will inevitably cause unbalances.



WHAT IS MOST IMPORTANT IS THAT ORIGINAL CONES AND ACCESSORIES, SPECIALLY DESIGNED TO BE EMPLOYED WITH THE WHEEL BALANCERS, ARE USED.

Wheel fitting using the cones provided is illustrated below. For alternative fittings, using optional accessories, refer to the special instructions provided separately.

12.1 Wheel assembly

For models with threaded chuck

1. Remove any type of foreign body from the wheel (**Fig. 32 ref. 3**): pre-existing weights, stones and mud, and make sure the chuck (**Fig. 32 ref. 1**) and the rim centring area are clean before fitting the wheel on the chuck.
2. Carefully choose the cone (**Fig. 32 ref. 2**) most suitable for the wheel to be balanced. These accessories must be selected according to the shape of the rim. Position the wheel (**Fig. 32 ref. 3**), fitting the cone (**Fig. 32 ref. 2**) on the chuck (**Fig. 32 ref. 1**): be careful (otherwise this could seize) until this rests against the support flange (**Fig. 32 ref. 4**).
3. Fit the wheel with the inner side of the rim towards the wheel balancer and against the cone.

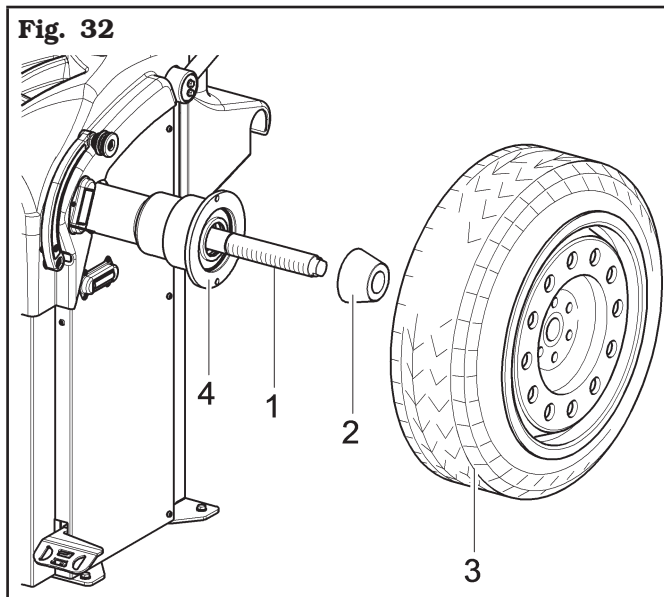

4. Fit the protection cap (**Fig. 33 ref. 1**) in the locknut (**Fig. 33 ref. 2**) and fasten against the wheel.

Fig. 33

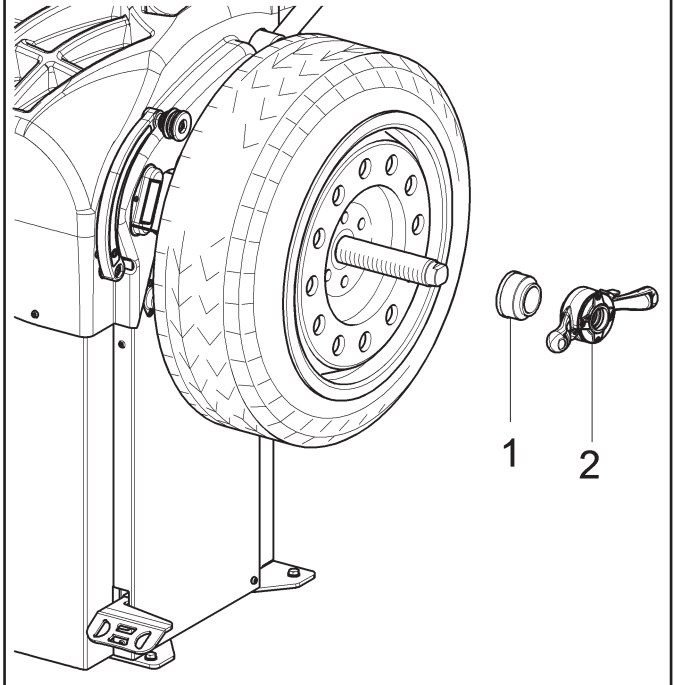

Some aluminium wheels, with very high centring, must be fitted with the cone outside the wheel.

5. Clean the chuck (**Fig. 34 ref. 1**) before fitting the wheel.
6. Fit the wheel (**Fig. 34 ref. 3**) with the inside of the rim towards the wheel balancer, until the wheel is up against the support flange (**Fig. 34 ref. 2**).

Fig. 34

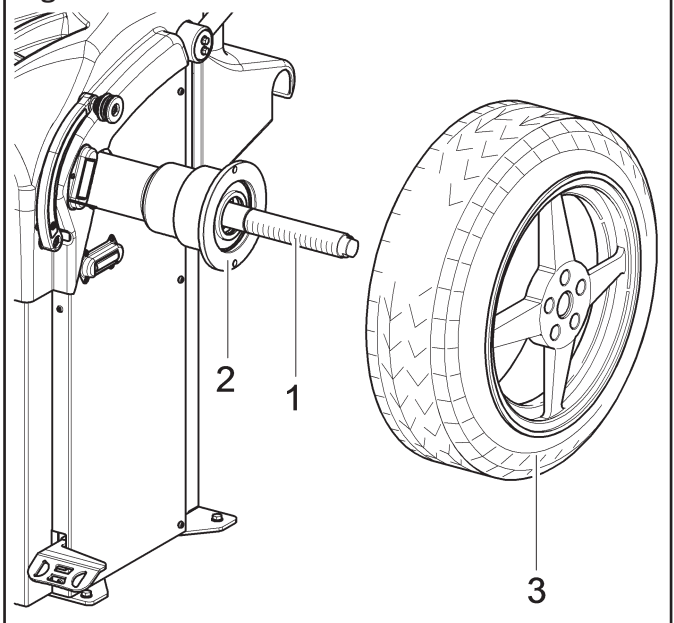

7. Fit the cone (**Fig. 35 ref. 3**) with the narrowest part turned towards the wheel.
8. Fit the pressure ring (**Fig. 35 ref. 1**) in the nut (**Fig. 35 ref. 2**) and fasten the cone (**Fig. 35 ref. 3**).

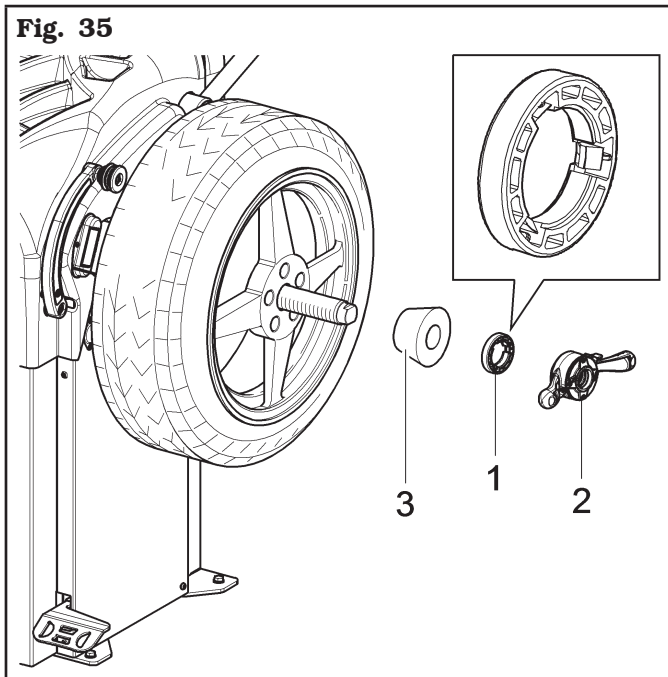

THE PRESSURE RING (FIG. 35 REF. A) MUST BE FITTED WITH THE TEETH OR DISCHARGE SIDE FACING THE LOCKING RING NUT (SEE FIG. 35).

12.2 Wheel assembly



On models with pneumatic chuck

Open the pneumatic chuck by means of the special pedal, see **Fig. 36**.

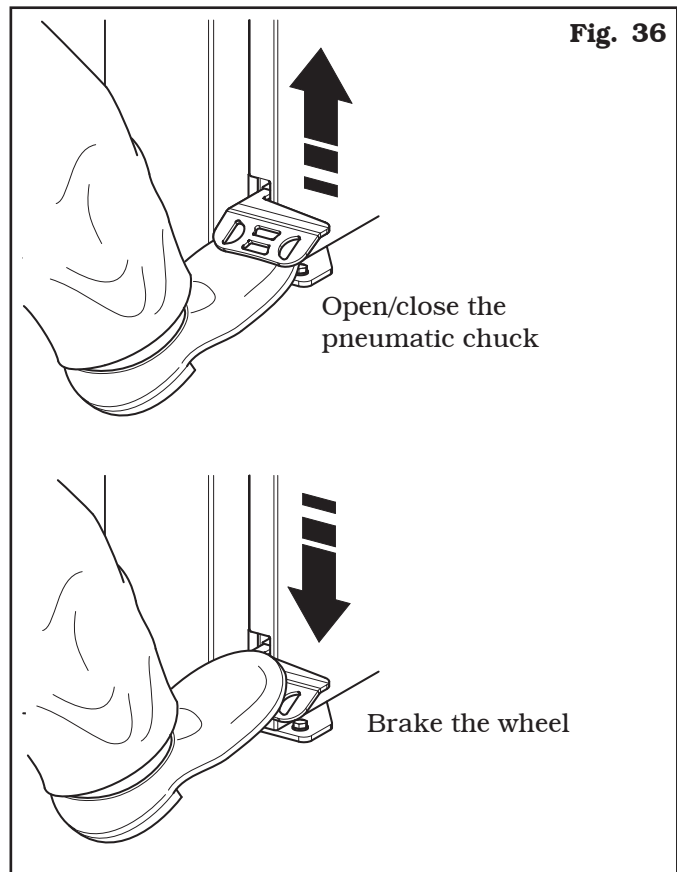

1. Remove any type of foreign body from the wheel (**Fig. 37 ref. 3**): pre-existing weights, stones and mud, and make sure the chuck (**Fig. 37 ref. 1**) and the rim centring area are clean before fitting the wheel on the chuck.
2. Carefully choose the cone (**Fig. 37 ref. 2**) most suitable for the wheel to be balanced. These accessories must be selected according to the shape of the rim. Position the wheel (**Fig. 37 ref. 3**), fitting the cone (**Fig. 37 ref. 2**) on the chuck (**Fig. 37 ref. 1**): be careful (otherwise this could seize) until this rests against the support flange (**Fig. 37 ref. 4**).
3. Fit the wheel with the inner side of the rim towards the wheel balancer and against the cone.

Fig. 37

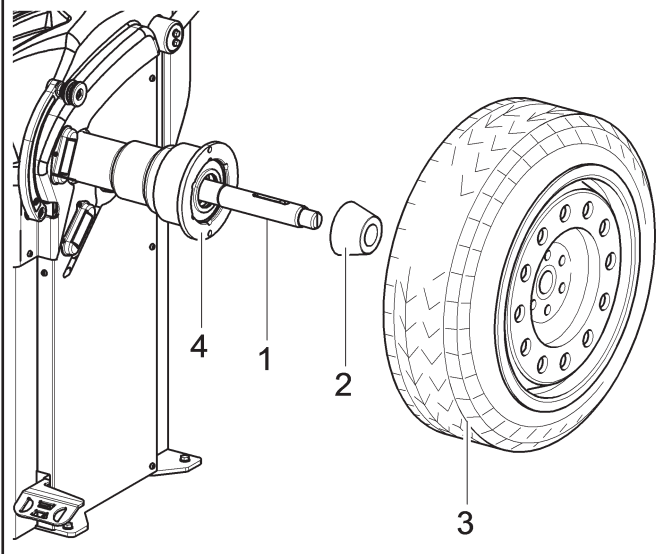

4. Fit the protection cap (**Fig. 38 ref. 1**) in the locking sleeve (**Fig. 38 ref. 2**) and bring everything against the wheel.

Fig. 38

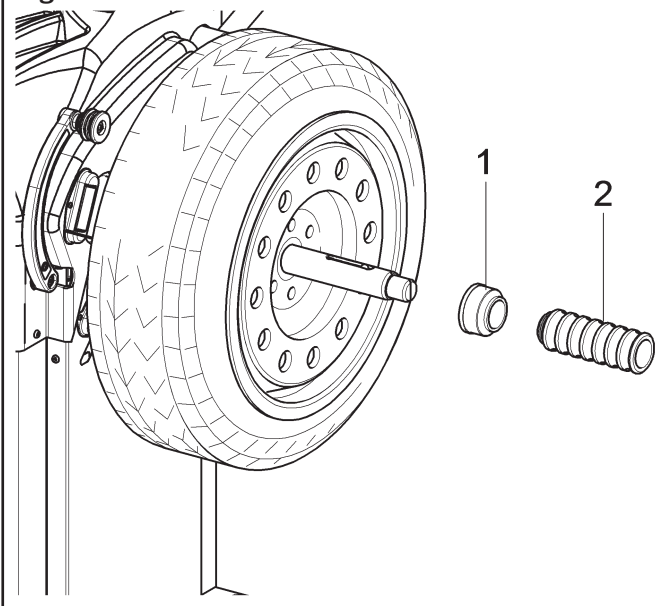

Lift the control pedal to close the chuck and then clamp the wheel.

Some aluminium wheels, with very high centring, must be fitted with the cone outside the wheel.

5. Clean the chuck before fitting the wheel.
6. Fit the wheel (**Fig. 39 ref. 3**) with the inside of the rim towards the wheel balancer, until the wheel is up against the support flange (**Fig. 39 ref. 2**).

Fig. 39

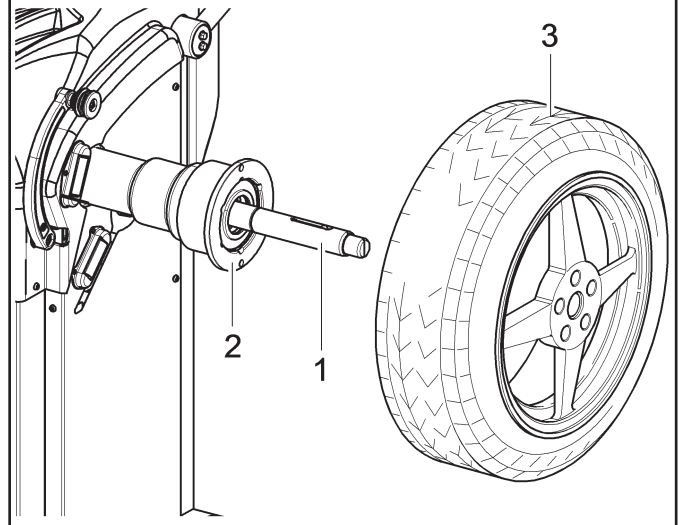

7. Fit the cone (**Fig. 40 ref. 3**) with the narrowest part turned towards the wheel.
8. Fit the pressure ring (**Fig. 40 ref. 1**) in the locking sleeve (**Fig. 40 ref. 2**) and bring everything against the wheel.

Fig. 40

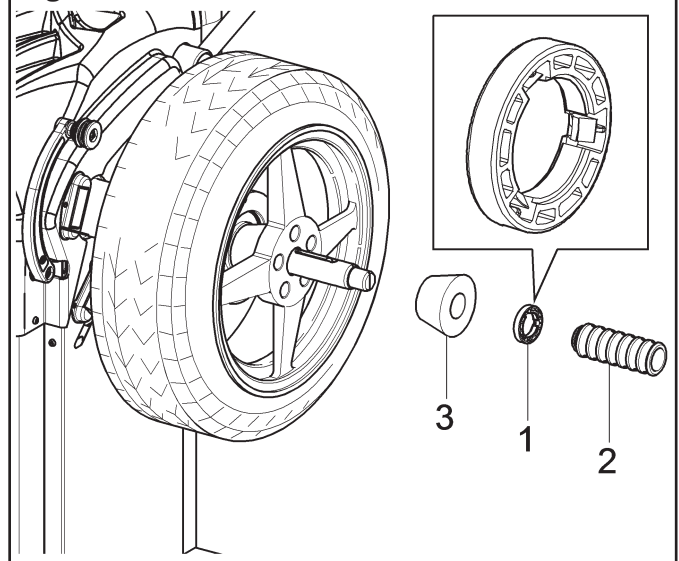

THE PRESSURE RING (FIG. 40 REF. 1) MUST BE FITTED WITH THE TEETH OR DISCHARGE SIDE FACING THE SLEEVE (FIG. 40 REF. 2).

Close the pneumatic chuck by lifting the appropriate control pedal.



DURING CHUCK OPENING/CLOSING OPERATIONS, BE CAREFUL TO KEEP YOUR HANDS AND OTHER PARTS OF THE BODY AWAY FROM THE MOVING CHUCK.

12.3 Adjustment of ultrasound sensor support (standard on some models)

Ultrasound sensor support (**Fig. 41 - Fig. 42 ref. 1**) must be used in the “fully-lowered” position, as shown in **Fig. 41**.

However with wheels with great diameter, you can set it higher so that the wheel can be mounted easily onto the chuck (see **Fig. 42**).

In order to carry out the adjustment, just loosen the handwheel (**Fig. 42 ref. 2**) and place the support in the wished position.

At the end tighten the handwheel (**Fig. 42 ref. 2**).

For what concerns exceptionally large wheels, sensor support may be moved outside the loading space of the same wheel, so that it can be easily mounted onto the chuck:

- slacken the handwheels (**Fig. 43 ref. 1**) fixed to the protection guard's tubular and open sensor support (**Fig. 43 ref. 2**) by making it slide in the slot (**Fig. 43 ref. 3**).

- slacken handwheel (**Fig. 43 ref. 4**) and raise sensor support (**Fig. 43 ref. 5**) then move it to the position required, as indicated in **Fig. 44 ref. 1**.

At the end tighten the handwheel (**Fig. 44 ref. 2**).

Fig. 41

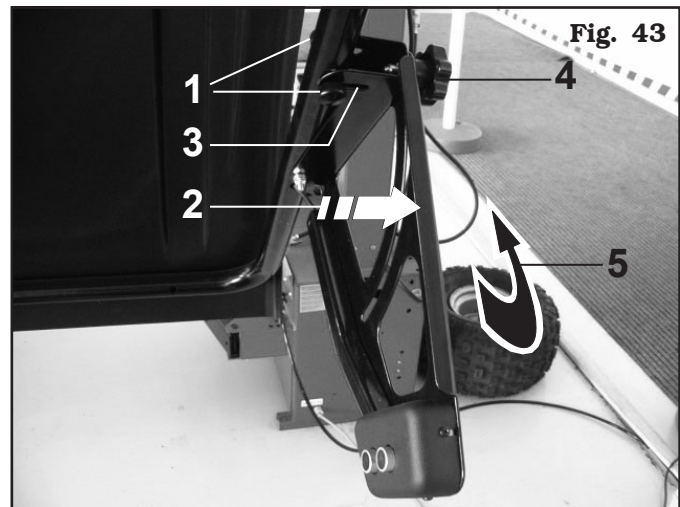
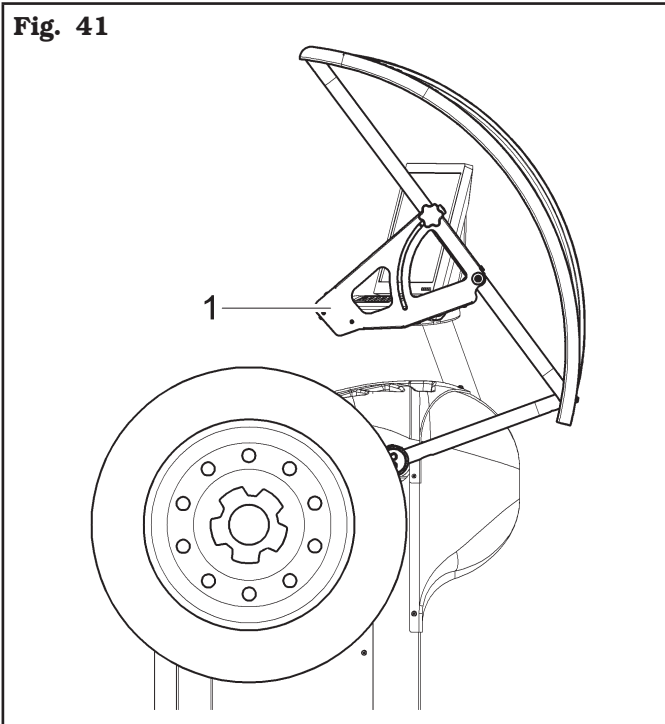

Fig. 43

Fig. 42

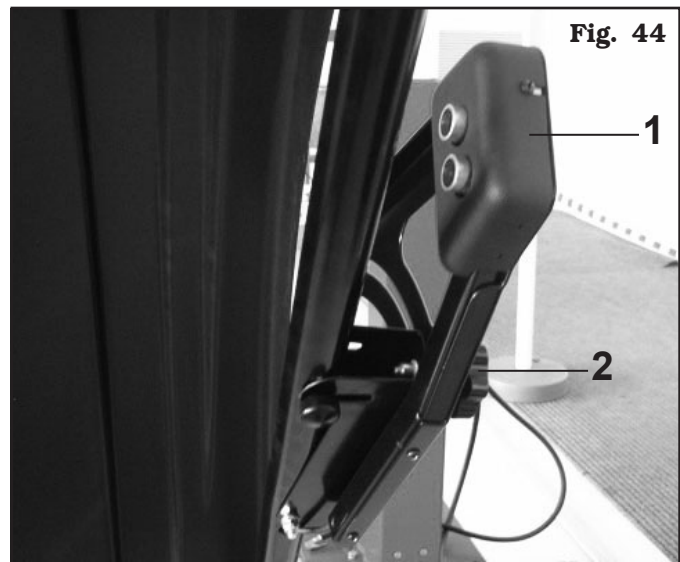
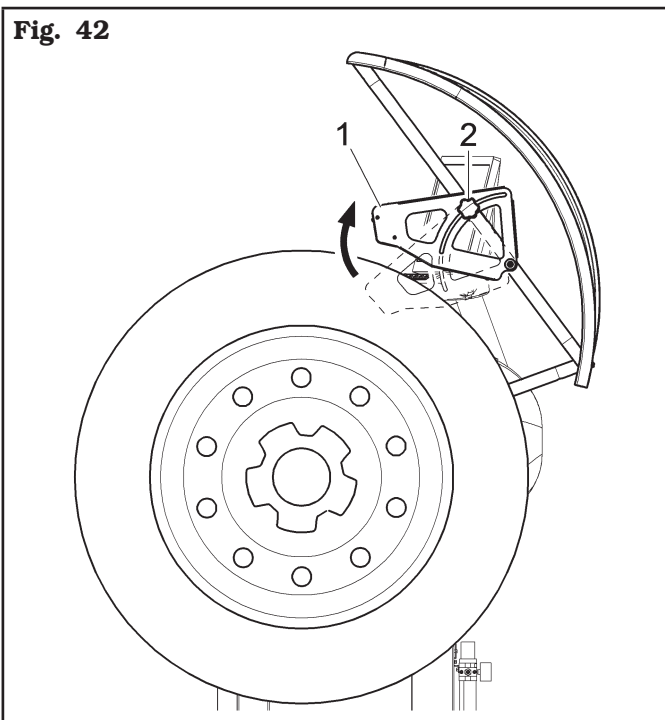

Fig. 44



IF ACTIVATED, EACH TIME THAT THE WHEEL PROTECTION GUARD IS LOWERED, THE DEVICE DETECTS AUTOMATICALLY THE DIMENSION OF THE WHEEL WIDTH.

12.4 Correct positioning of the ultra-sound Run-out detecting device (optional on some models)

To make sure that the rim/tyre "Run-out" detection is correct, place the device as shown in **Fig. 45**: place the measurement sensor so that it is turned towards tyre centre line.

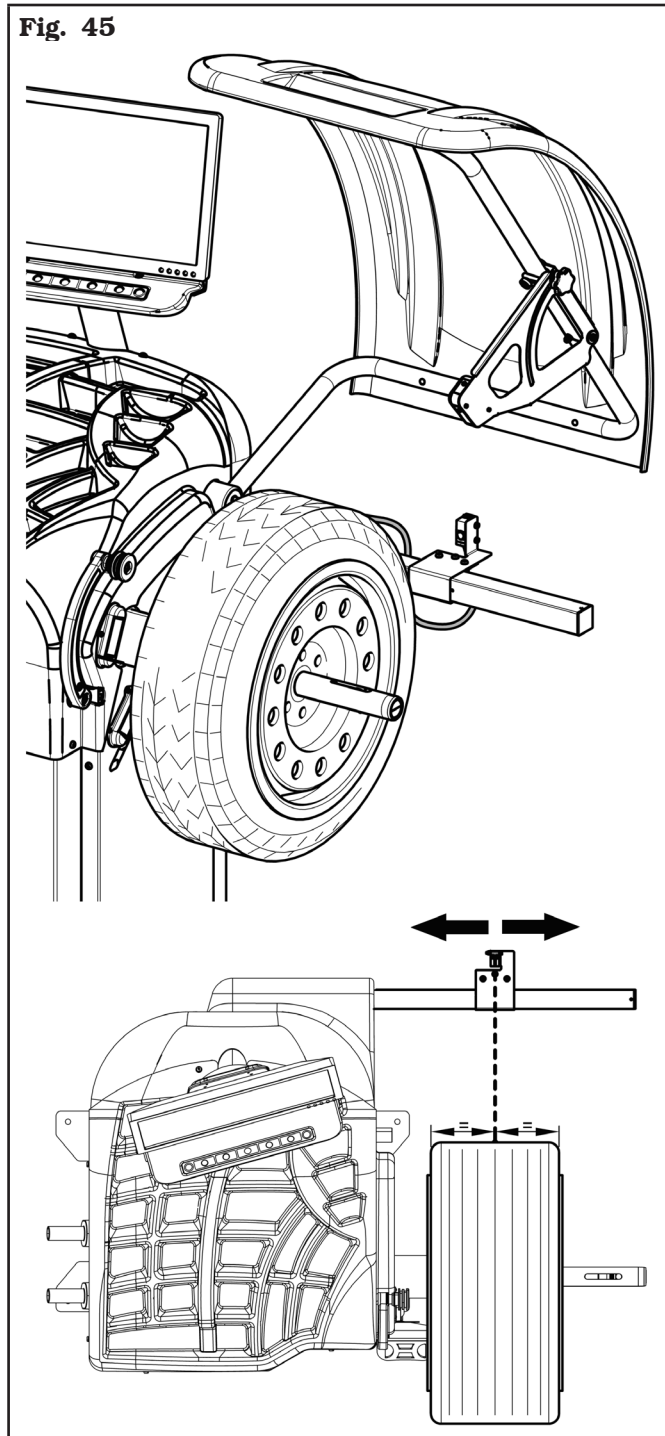

13.0 CONTROL PANEL

The wheel balancers are equipped with a control panel with a 7-key-keyboard (**Fig. 46A ref. 1**) or, on demand, with a touch control panel (**Fig. 46B ref. 1**) (for touch screen monitor).

On both the control panels are displayed all the instructions for the correct wheel balancing, for example indicating where the operator shall fit adhesive or clip weights and the balancing mode and/or option used, as well as correct wheel rotation for inner/outer weights positioning.



TO INTERACT/OPERATE THE CONTROLS PRESENTED IN GRAPHICAL FORM ON THE MONITOR, IN THE VERSION WITH CONTROL PANEL WITH KEYBOARD, PRESS ON THE RELEVANT KEY ON THE LOWER KEYBOARD, WHEREAS PRESS DIRECTLY ON THE ICON PRESENTED IN GRAPHICAL FORM ON THE MONITOR ITSELF IN CASE OF TOUCH CONTROL PANEL (ON DEMAND).

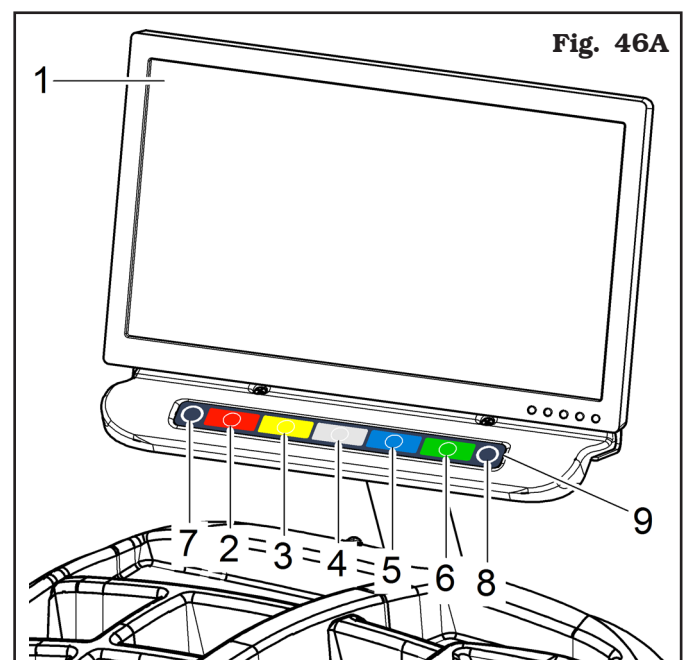

KEY

- 1 - Monitor
- 2 - Function push button (red)
- 3 - Function push button (yellow)
- 4 - Function push button (grey)
- 5 - Function push button (blue)
- 6 - Function push button (green)
- 7 - Previous page push button
- 8 - Next page/print push button
- 9 - Push button panel (keyboard with 7 keys)



Touch screen (optional)

Fig. 46B

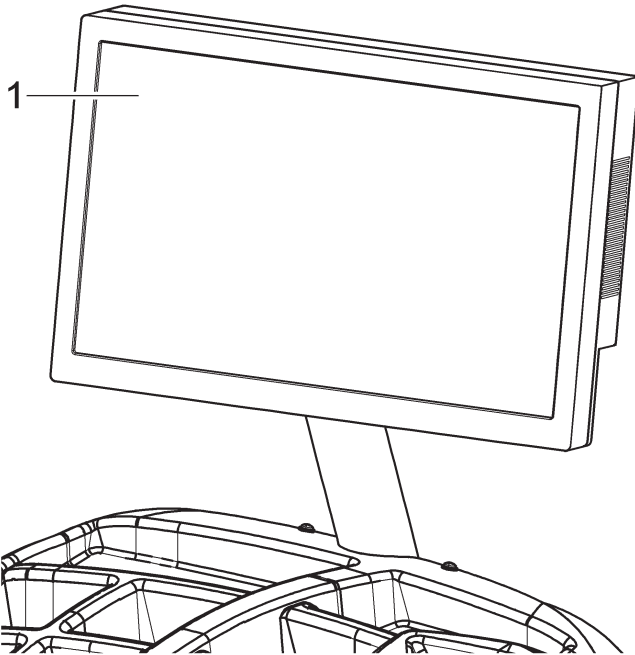

KEY

1 - Monitor with touch control panel



IN THIS MANUAL ARE DESCRIBED THE CONTROL OPERATIONS USING THE MONITOR WITH KEYBOARD. IN CASE OF TOUCH MONITOR, TO SELECT THE COLOURED KEYS ON THE SCREEN, SIMPLY TOUCH THEM.

14.0 WHEEL BALANCING

14.1 Switching the machine on and off

Press the "ON" switch (**Fig. 30 ref. 1**), located in the rear part of the equipment.



IN THE CASE OF PNEUMATIC MODELS, ON STARTING UP, THE PNEUMATIC CHUCK IS ALWAYS OPENED. ALWAYS KEEP YOUR HANDS AND OTHER PARTS OF THE BODY AWAY FROM THE MOVING CHUCK. ALSO TAKE CARE IF A WHEEL IS ALREADY FITTED ON THE CHUCK, AS THIS COULD BE FORCED OFF THE SHAFT DURING THE OPENING OF THE CHUCK ITSELF.

Wait a few seconds up to the complete loading of the operational program. The equipment is ready to operate when the main screen "Home" appears on the monitor.

Fig. 47



KEY

A - Displaying operations/information area

B - Colours for identification of the buttons to be used

C - Function icons

1 - Programs and measurements acquisition buttons

2 - Wheel spin push button

3 - Go to next page

4 - Pneumatic chuck opening/closing (on models with pneumatic chuck) (generally used in case of emergency)

5 - User management (if enabled) (user management function is disabled on machine delivery)

At the bottom of the main screen page and of each screen page described below, there will be coloured rectangles (**Fig. 47 ref. B**) located above function identification icons (**Fig. 47 ref. C**). These functions are activated by pressing the appropriate coloured button on the push-button panel (**Fig. 46A ref. 9**).

Only for touch screen monitor

All the push buttons on the lower bar (**B**) can be selected by touch.

For both versions

Press the button (**Fig. 47 ref. 3**) to display a second page where you can access the "Technical assistance" menu and the "Run-out" menu (see **Fig. 48**).

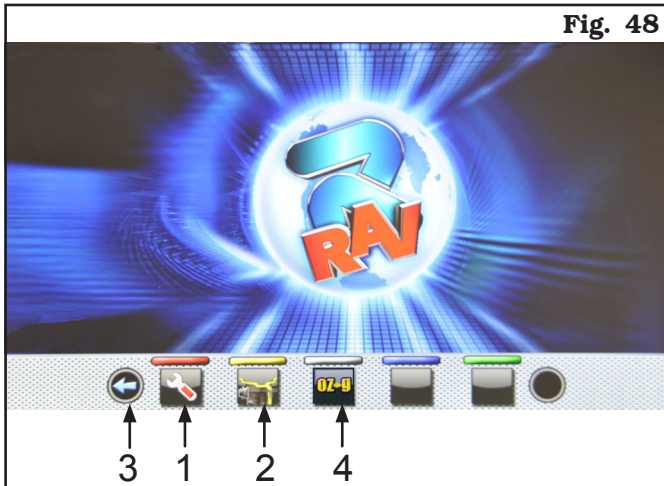

Fig. 48

KEY

- 1 – User menu
- 2 – Run-out menu (visible only if the machine is fit or if the Run-out device is enabled)
- 3 – Return to previous page
- 4 – Measurement unit setting.

The machine is supplied with "grams" option



enabled (see Chap. 15.0), so weights will be displayed only in grams and no icons will be displayed onto push button 4.



In order to modify the measurement unit carry out the following procedure: if "ounce" option



is activated from user menu (see Chap. 15.0), "ounce" weight displaying mode is set,

and push button  will be displayed. Press

the button  to set machine weight display in grams and on the screen will be displayed

icon . Press the button  to set machine weight display in ounces and on the screen

will be displayed icon .

In order to turn off the machine, simply press the "OFF" main switch (**Fig. 30 ref. 1**).



WHEN THE EQUIPMENT IS TURNED OFF LOSES ALL THE MEASUREMENTS AND THE STORED DATA (SIZE, SPINS, USERS, ETC ...). AT RESTARTING,



PRESSING THE BUTTON (IN THE CASE HAVE NOT YET BEEN STORED ON THE NEW MEASURES AFTER THE SWITCHING ON), THE MACHINE DOES NOT PERFORM ANY OPERATION.

14.2 Balancing programs setting

The setting of the balancing programs can be performed in two ways:

- through the gauge arm (rapid setting);
- through "Measurement being acquired" screen, ap-



pearing when the button is pressed (**Fig. 47 ref. 1**).

The setting modes are completely different even if they allow to reach the same result (but with different times).

14.2.1 Programs rapid setting and measurements through distance-diameter caliper arm

The use of the distance-diameter caliper arm allows the rapid automatic wheel balancing program and the measures entry. From page "Home":

- bring into contact the weights fitting gripper with the inner part of the rim (1 contact only) to select the program "STATIC" (see Fig. 49).



Fig. 49



REPEATEDLY BRINGING THE GAUGE ARM (FIG. 50 REF. 1) IN CONTACT WITH THE CHUCK (FIG. 50 REF. 2), THE PROGRAM WILL CYCLE FROM "STATIC" TO "STATIC 1" TO "STATIC 2" RETURNING THEN AT THE BEGINNING.

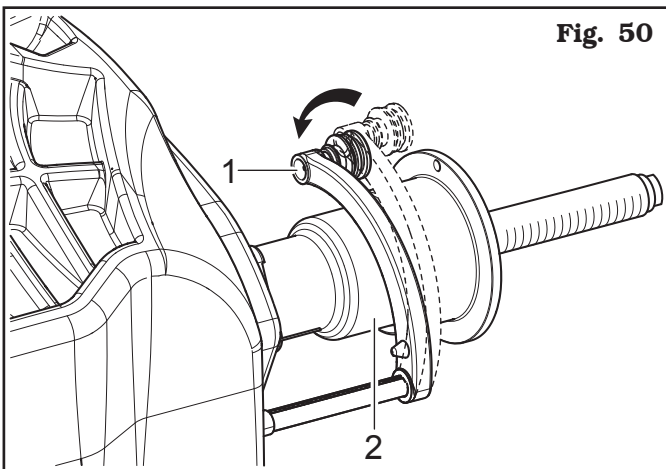

Fig. 50

- bring into contact the weights fitting gripper with the inner part of the rim (2 contact points) (see Fig. Fig. 49) to select "ALU-S" program.



REPEATEDLY BRINGING THE CALIPER ARM (FIG. 50 REF. 1) IN CONTACT WITH THE CHUCK (FIG. 50 REF. 2), THE PROGRAM WILL CYCLE FROM "ALU-S" TO "ALU-S1" TO "ALU-S2", RETURNING THEN AT THE BEGINNING.



WHENEVER THE DISTANCE-DIAMETER CALIPER AND/OR THE EXTERNAL DATA GAUGE (SEE FIG. 51 (IF ANY)) IS KEPT IN POSITION FOR A FEW SECONDS AGAINST THE RIM (UNTIL THE MACHINE MAKES AN APPROPRIATE SOUND NOTIFICATION), THE POSITION IS STORED AND THE VALUES MEASURED IN THE PRE-ARRANGED FIELDS IN THE SELECTED WHEEL BALANCING PROGRAM ARE LOADED.

Fig. 51

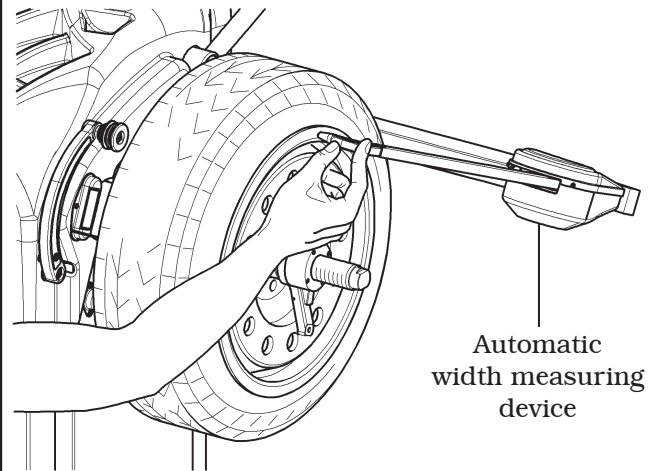
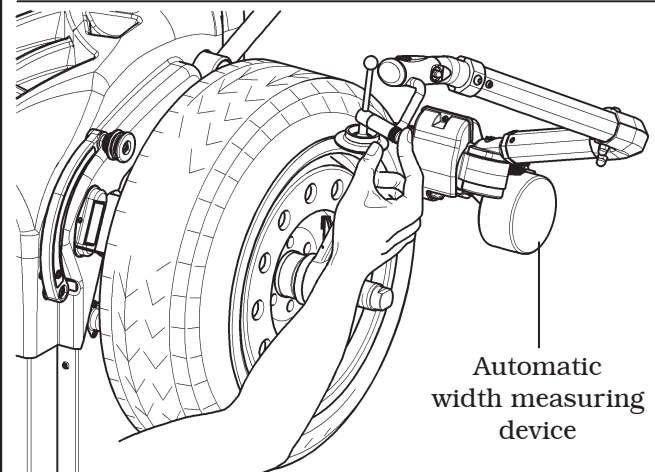
Automatic
width measuring
deviceAutomatic
width measuring
device

(OPTIONAL)

- After entering all the required measures, you can spin the wheel by pressing the button  and closing the protective guard.

Standard on some models



EACH TIME THAT WHEEL PROTECTION GUARD (FIG. 52 REF. 1) IS CLOSED, THE AUTOMATIC WIDTH MEASURING DEVICE UNIT (FIG. 52 REF. 2) MEASURES THE WIDTH OF THE WHEEL THAT IS MOUNTED ON THE CHUCK AND PERFORMS THE SPIN. THE RELEVANT VALUE IS STORED AUTOMATICALLY IN THE PRE-ARRANGED FIELD OF THE CHOSEN BALANCING PROGRAM.

Fig. 52

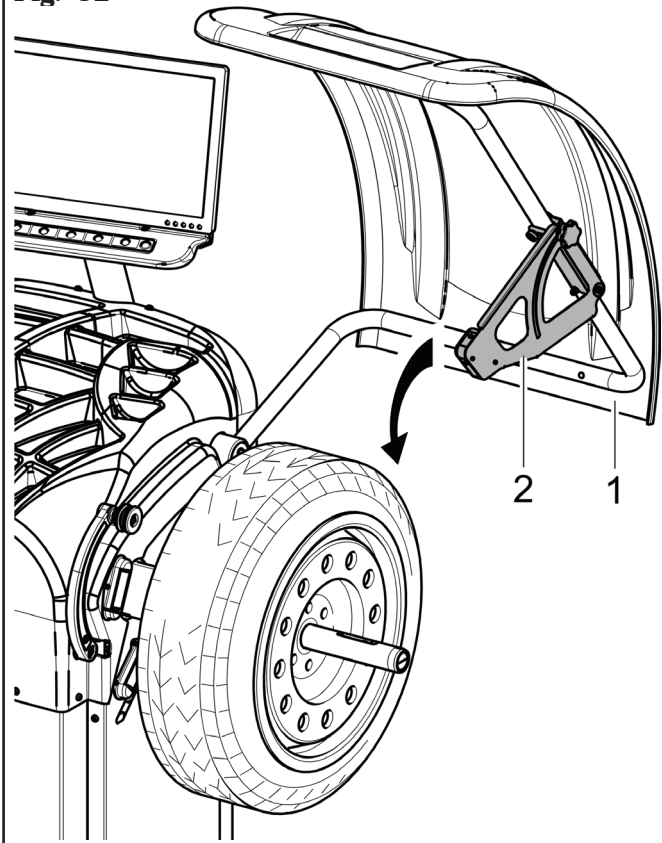

- **Measuring procedure of electronic RUN-OUT with the distance-diameter caliper arm.**

The electronic RUN-OUT measuring device is useful to check if the rim has some imperfections. To access the screen to choose the rim control mode, proceed as follows:

- from the "Home" page, press the button 

(Fig. 53 re. 1) and then the button  (see Fig. 54 ref. 1).

Fig. 53



Fig. 54



- The following screen page will appear on the monitor:



- Place the distance-diameter caliper grippers (**Fig. 56 ref. 1**) in contact with the rim.

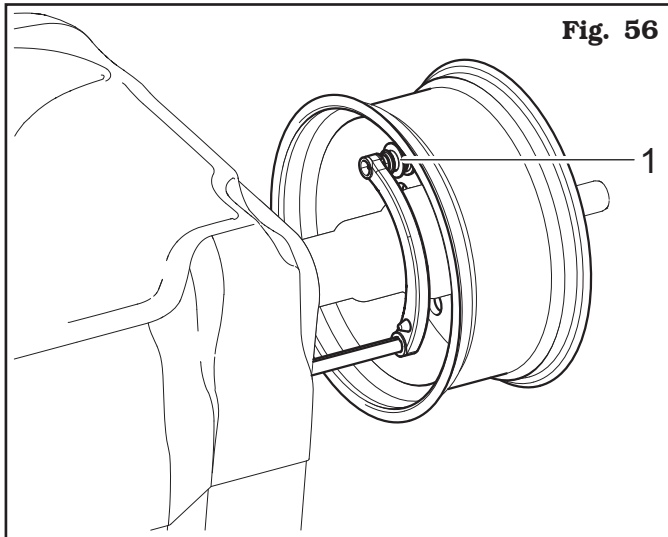

Press the green button on the monitor  to start the rim analysis procedure. The circle starts to spin at low speed (30 rpm) and at the end of the measurement the eccentricity graph appears, as shown in the **Fig. 57**.

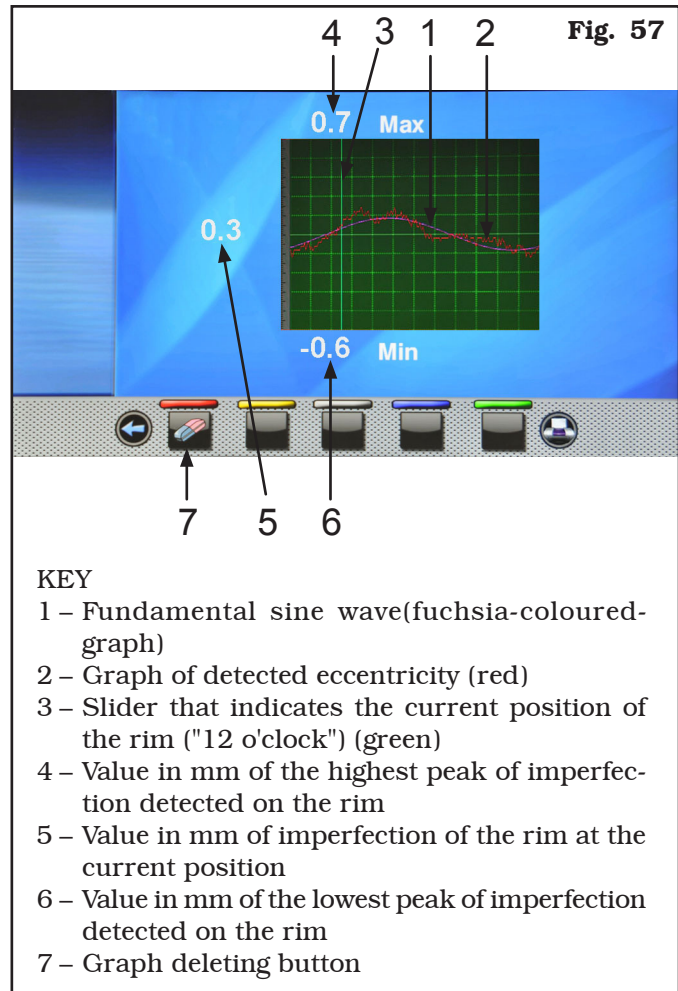



The red graph (**Fig. 57 ref. 2**) represents exactly the geometric shape of the rim. The more the circle is round and linear, the more the graph is flat, unlike the more the circle has deficiencies, the more the graph is large.

You can follow the eccentricity in the graph by manually turning the rim, the green-coloured-slider (**Fig. 57 ref. 3**), indicates the position of the rim in "12 o'clock" position.



14.2.2 Programs setting through "Measurements acquisition" screen page

From the "Home" page, press the  (Fig. 47 ref. 1) button to display "Measurements acquisition" screen page below:



 **PRESS THE BUTTON  (FIG. 47 REF. 1) TO DISABLE THE AUTOMATIC FUNCTIONS FOR THE SELECTION OF THE BALANCING PROGRAM OF DISTANCE-DIAMETER CALIPER ARM, DESCRIBED IN PAR. 14.2.1. TO BE ABLE TO REUSE THE AUTOMATIC FUNCTION TO SELECT THE WHEEL BALANCING PROGRAM WITH GAUGE ARM, IT IS NECESSARY TO RETURN TO "HOME" PAGE, BY PRESSING THE  BUTTON.**

The selection of the wheel balancing program is possible in 2 ways:



- with highlighted program (blue colour) by pressing the  or  until you see the desired program.

With this mode only the 11 standard programs can be selected (DYN, ALU-S, ALU-S1, ALU-S2, STAT, STAT-1, STAT-2, ALU-1, ALU-2, ALU-3, ALU-4).

 **IF THE PROGRAM NAME IS NOT HIGHLIGHTED (BLUE), PRESS THE BUTTON  REPEATEDLY UNTIL THE ABOVE CONDITION IS REACHED.**

- Press the button  to display the following programs selection screen page:



Use the arrows  and/or  to select the wished mode (blue). In this mode you can select the 11 standard programs (listed above) and special programs (PAX360, PAX420, PAX460, PAX700).

 **AFTER YOU HAVE SELECTED THE DESIRED PROGRAM, USE THE DISTANCE-DIAMETER CALIPER AND/OR THE EXTERNAL DATA GAUGE (IF ANY) TO DETECT THE MEASURES REQUIRED BY THE PROGRAM.**

 **WHENEVER THE DISTANCE-DIAMETER CALIPER AND/OR THE EXTERNAL DATA GAUGE (SEE FIG. 51 (IF ANY)) IS KEPT IN POSITION FOR A FEW SECONDS AGAINST THE RIM (UNTIL THE MACHINE MAKES AN APPROPRIATE SOUND NOTIFICATION), THE POSITION IS STORED AND THE VALUES MEASURED IN THE PRE-ARRANGED FIELDS IN THE SELECTED WHEEL BALANCING PROGRAM ARE LOADED.**

 **EACH TIME THAT THE WHEEL PROTECTION GUARD IS CLOSED; THE AUTOMATIC WIDTH MEASURING DEVICE (FIG. 1 REF. 15) (IF PRESENT) MEASURES THE WIDTH OF THE WHEEL THAT IS MOUNTED ON THE CHUCK. THE RELEVANT VALUE IS STORED AUTOMATICALLY IN THE PRE-ARRANGED FIELD OF THE CHOSEN BALANCING PROGRAM.**

- After entering all the required measures, you can spin the wheel by pressing the button  and closing the protective guard.

14.3 Indicative display of points where to detect measures/to fit weight



IT IS VERY IMPORTANT TO REMEMBER THE POINTS SELECTED FOR MEASUREMENT INSIDE THE RIM SINCE DURING THE WEIGHTS FITTING AT "6 O'CLOCK" (WITH OR WITHOUT FIXED LASER), THERE ARE NO DIFFERENCES, EXCEPT FOR A TRANSVERSAL LINE ON THE RIM, PRODUCED BY THE FIXED LASER ITSELF, IF ANY. HOWEVER THE POSITIONING IN DEPTH WILL BE AT THE DISCRETION OF THE OPERATOR.

Depending on the type of program selected, the machine shows on the monitor the guideline points where to take measures and, consequently, where you must apply weights (**Fig. 58 ref. 4-5**).

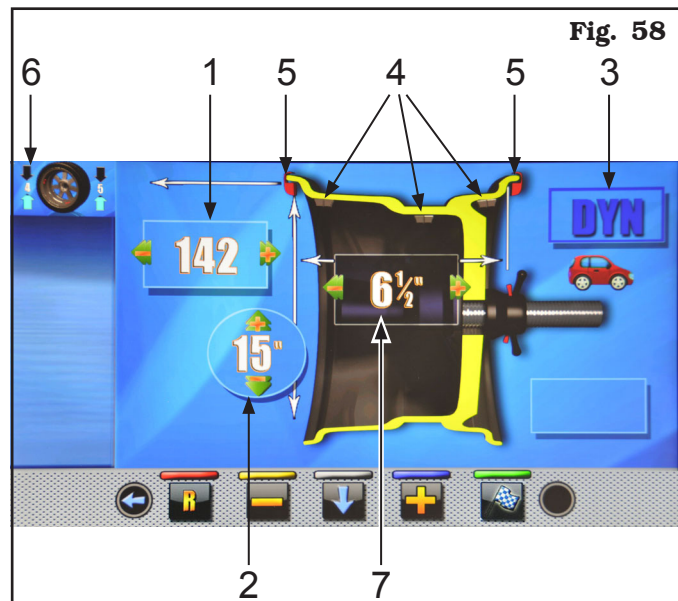

KEY

- 1 – 1st weight fitting point distance
- 2 – Rim diameter
- 3 – Balancing mode
- 4 – Point at which to take the measure/adhesive weight fitting
- 5 – Point at which to take the measure/clip weight fitting
- 6 – Last unbalance detected by the machine
- 7 – Rim width



THE MORE THE POINTS CHOSEN FOR THE PROBING ARE DISTANT FROM EACH OTHER THE MORE THE BALANCING WILL BE EFFECTIVE.

14.3.1 Weights positioning

The monitor displays when it is absolutely necessary that the weight is applied at "12 o'clock" position. Pay particular attention to the content of the weights identification icons since if the following words **H 12** are displayed, then the icon corresponding weight has to be applied at "12 o'clock" position (typical of ALU-S1, ALU-S2 programs).





IF ALL MEASURES REQUIRED BY THE PROGRAM HAVE NOT BEEN TAKEN/INSERTED, THE MACHINE DOES NOT ALLOW THE WHEEL SPIN TO DETECT THE UNBALANCE.

14.4 Displaying the active/modifiable field

During the various phases of measures detection, the active field turns blue.



Pressing the buttons  or  you can change the value and/or program inside the active field. To change the selected active field, simply press the button



until the desired field is coloured blue.



THE SELECTION OF THE ACTIVE FIELD IS DONE BY HIGHLIGHTING THE FIELDS IN A CLOCKWISE DIRECTION.

NORMALLY DURING THE DETECTION OF MEASUREMENTS, THE 1ST ACTIVE FIELD WILL BE THE ONE FOR THE SELECTION OF THE PROGRAM.



THERE IS A CASE, HOWEVER, IN WHICH THE 1ST ACTIVE FIELD WILL BE THE RIM WIDTH.



THIS CASE WILL OCCUR ONLY IF FROM "HOME" PAGE IS DETECTED ONLY ONE MEASUREMENT INSIDE THE RIM. THE PROGRAM WILL AUTOMATICALLY SET TO "STATIC" BUT IT WILL MAKE IT POSSIBLE (IN CASE OF ABSENCE OF EXTERNAL DATA GAUGE) TO MANUALLY ENTER RIM WIDTH AND TO QUICKLY SWITCH TO THE PROGRAM "DYNAMIC".

14.5 Wheel balancing screen page description

After executing the spin of the wheel, the monitor displays a series of important information that helps the operator in his operations and subsequent choices.

Fig. 59

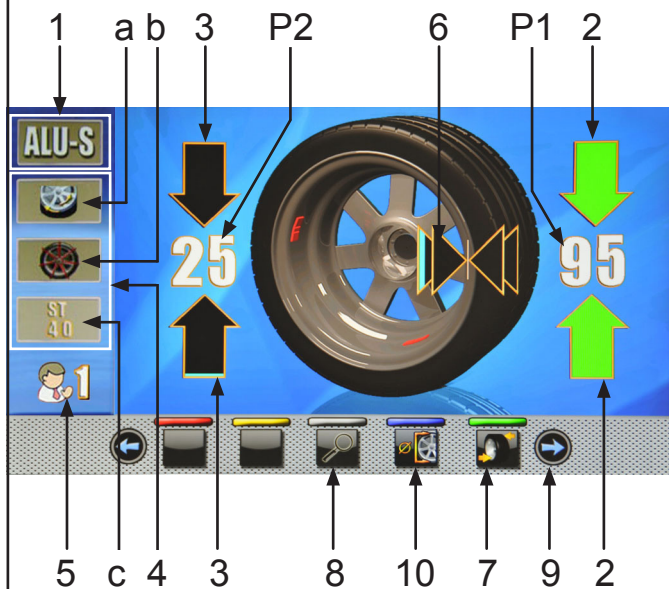

KEY

- 1 - Balancing mode
- P1 - Weight to be fitted on rim outer side
- P2 - Weight to be fitted on rim inner side
- 2 - Wheel placed to fit the weight on wheel outer side (arrows both green)
- 3 - Wheel not placed to fit the weight on wheel inner side (blue/black arrows)
- 4 - Wheel balancing suggestions
- 4a - MATCHING program
- 4b - SPOKES program (adhesive weights program) or SPLIT program (clip weights program)
- 4c - STATIC Program
- 5 - N° user (if selected)
- 6 - Arrows indicating the weight fitting point with distance-diameter caliper arm
- 7 - Wheel repositioning button for weights fitting
- 8 - Display of the weight with the maximum resolution of 1 g / 0,05 oz
- 8a - Display of the weights in grams
- 8b - Display of the weights in ounces/grams
- 9 - By pressing the button you will see the following page where you can select one of the programs suggested by the machine.
- 10 - Programs and measurements acquisition buttons



IF THE GUARD AND REPOSITIONING FUNCTION ARE DISABLED, ON THE BUTTON IN POS. 7 FIG. 59, YOU WILL SEE THE



ICON THAT WILL ALLOW WHEEL SPIN WITHOUT RETURNING TO THE PREVIOUS PAGE. THE POSITIONING OF THE WHEEL FOR THE APPLICATION OF THE WEIGHTS MUST BE DONE MANUALLY.

8a-Display of the weights in GRAMS

Set the unit of measurement for weights

display to GRAMS (see Par. 15.1 "Options menu").

On the following screen page:



press the button to display the weight with maximum resolution (1g) to be fitted on the wheel, expressed in grams.

The following screen will appear on the monitor:



Press again the button  to display the approximated weight to be fitted to the wheel, expressed in grams.



7b-Display of the weights in OUNCES/GRAMS
Set the unit of measurement for weights

display to OUNCES/GRAMS  (see Par. 15.1 "Options menu").

On the following screen page:



press the button  to display the weight with maximum resolution (0.05 oz) to be fitted on the wheel, expressed in ounces. The following screen will appear on the monitor:



Press the button  to set the display of the weights to be fitted on the wheel in grams. The following screen will appear on the monitor:



Press the button  to display the weight with maximum resolution (1g) to be fitted on the wheel, expressed in grams. The following screen will appear on the monitor:



Press the button  to set the display of the weights to be fitted again in ounces. The following screen will appear on the monitor:



14.5.1 Balancing mode

The machine has the ability to perform the wheel balancing (weights fitting) in 4 different ways:

- using the distance-diameter caliper arm with weights fitting grippers;
- using the fixed laser at "6 o'clock" (optional on some models);
- using the mobile laser pointer at "6 o'clock" (standard on some models)
- weights fitting at "6 o'clock" (without the use of laser emitter);
- weights fitting at "12 o'clock" (with the use of laser emitter) (optional).

• **Weights fitting with distance-diameter caliper and grippers.**

1. Place the adhesive weight on the arm grippers.

Fit the adhesive weight
in the pliers of the gauge rod



2. Pull out the gauge until the arrows (**Fig. 59 ref. 6**) both turn green.
3. Rotate the gauge arm until the weight touches the rim.

Fit weight on the position
where pliers touches the wheel



4. Bring the distance-diameter caliper arm in resting position, after having led it towards the chuck to unlock it from the position of weight application.





5. Press the  button to change the weight fitting side.
6. Proceed in the same way as described in points 1-2-3.



BEFORE REMOVING THE DIAMETER-DISTANCE CALIPER, PRESS THE BRAKE PEDAL AND HOLD IT DOWN UNTIL THE WEIGHT HAS NOT BEEN APPLIED, ENSURING IN THIS WAY THAT, DURING THESE PHASES, THE WHEEL CAN NOT ROTATE.

- **Weights fitting with fixed laser at "6 o' clock" (optional on some models).**



 ON DELIVERY THE MACHINE (IF PRE-SET WITH FIXED LASER) IS SET WITH THE CORRESPONDING OPTION DESELECTED. TO USE THIS MODE, IT IS NECESSARY THAT THE RELEVANT FUNCTION IS ENABLED  ON THE MENU "OPTIONS" DESCRIBED IN PAR. 15.1.

 TO USE THIS WEIGHT APPLICATION MODE THE OPERATOR MUST REMEMBER THE PRECISE POINT WHERE THE MEASUREMENT WAS TAKEN WITH THE DISTANCE-DIAMETER CALIPER ARM.

At the end of the spin, on the rim at "6 hours" is displayed a laser beam (emitter) indicating the axis on which to apply the weight. The positioning of the weight (s) in depth shall be at the discretion of the operator, depending on where remembers taking the measure.

 BE SURE TO APPLY THE (INTERNAL OR EXTERNAL) WEIGHT AS INDICATED BY THE 2 GREEN ARROWS (FIG. 59 REF. 2 OR 3) ON THE CORRESPONDING MONITOR SCREEN.

- **Weights fitting with mobile laser pointer "at 6 o'clock" (standard on some models)**

 ON DELIVERY, THE MACHINE IS CONFIGURED WITH THE CORRESPONDING OPTION DESELECTED. TO USE THIS MODE, IT IS NECESSARY THAT THE RELEVANT FUNCTION IS ENABLED  ON THE MENU "OPTIONS" DESCRIBED IN PAR. 15.1.

At the end of the spin, on the rim at "6 hours" is displayed a laser pointer indicating the exact point where the weight has to be applied.

 THE WEIGHT HAS TO BE APPLIED FROM THE POINT HIGHLIGHTED BY THE POINTER TOWARDS THE INSIDE OF THE RIM, AND ITS CENTRE LINE MUST BE RIGHT BY THE SAME POINTER (SEE FIG. 60).

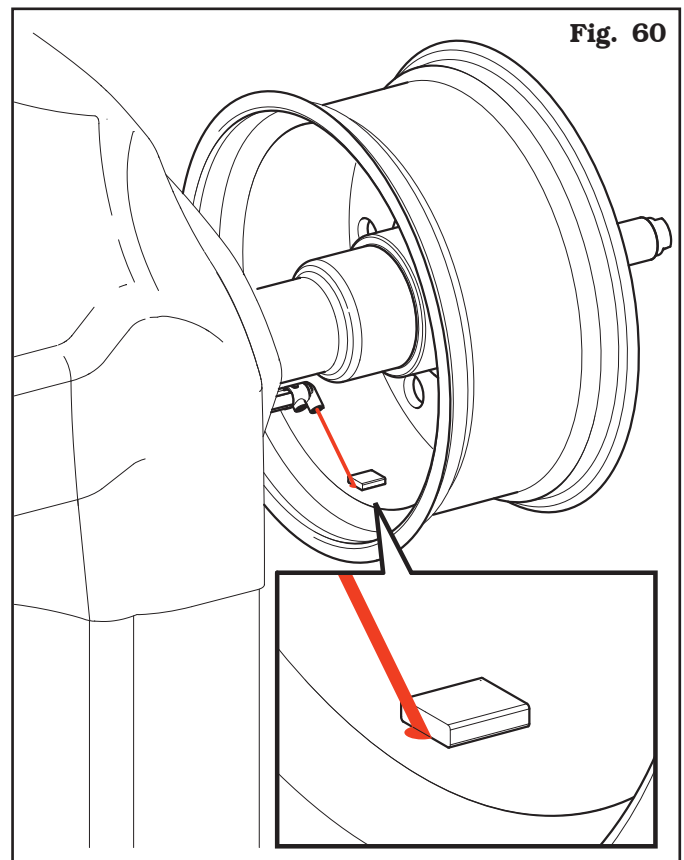



- Weights fitting at "6 o'clock" (without the use of laser emitter).



TO USE THIS MODE, IT IS NECESSARY THAT THE RELEVANT FUNCTION IS ENABLED



ON THE MENU "OPTIONS" DESCRIBED IN PAR. 15.1.



TO USE THIS WEIGHT APPLICATION MODE THE OPERATOR MUST REMEMBER THE PRECISE POINT WHERE THE MEASUREMENT WAS TAKEN WITH THE DISTANCE-DIAMETER CALIPER ARM.



USING THIS MODE, THE MACHINE ALLOWS YOU TO APPLY ANY ADHESIVE WEIGHTS THAT WOULD BE APPLIED TO "12 HOURS" TO "6 O'CLOCK". IF, AFTER YOU ENABLE THIS MODE, ON BALANCING PROGRAM APPEARED AGAIN THE **H 12** ICON (ONLY IN THIS CASE) THE ADHESIVE WEIGHT WILL BE APPLIED TO "12 HOURS".

At the end of the spin, the wheel stops in place to apply the weight at "6 o'clock". The positioning of the weight (s) in depth shall be at the discretion of the operator, depending on where remembers taking the measure.



BE SURE TO APPLY THE (INTERNAL OR EXTERNAL) WEIGHT AS INDICATED BY THE 2 GREEN ARROWS (Fig. 59 ref. 2 or 3) ON THE CORRESPONDING MONITOR SCREEN.

- Weights fitting at "12 o'clock" (with the use of laser emitter) (optional).



TO USE THIS MODE, IT IS NECESSARY THAT THE RELEVANT FUNCTION IS ENABLED



ON THE MENU "OPTIONS" DESCRIBED IN PAR. 15.1.

This function indicates, through the 2 laser pointers placed on the machine (frame and wheel cover), the centre line position (at "12 o'clock") of the counterweight in the programs that require the clip weights (ex: dynamic) for the wheel balancing.

Therefore, at the end of the measuring cycle, when the wheel stops in position to fit the clip weight (green arrows on the screen), the laser corresponding to the side to balance turns on, projecting a line onto the rim edge.

14.6 Use of machines with disabled automatic data gauge

The entry of diameter, width and distance measures of the machine rim must be performed manually. The reading of these measures can be made as follows:

- visual readout on caliper graduated scale (distance);
- values readout on rim (diameter and width);
- width value detection with manual caliper (width) (see **Fig. 61**).







MANUAL CALIPER.
Width manual detection

Fig. 61

14.6.1 Manual setting of wheel dimensions

In case the operator wants to edit and/or manually enter the wheel dimensions, proceed as follows:

- from the desired measurement mode screen, press the button  until highlighting with blue the field to modify/edit;
- press the buttons  or  until reaching the desired value;
- press button  to shift to the next value.

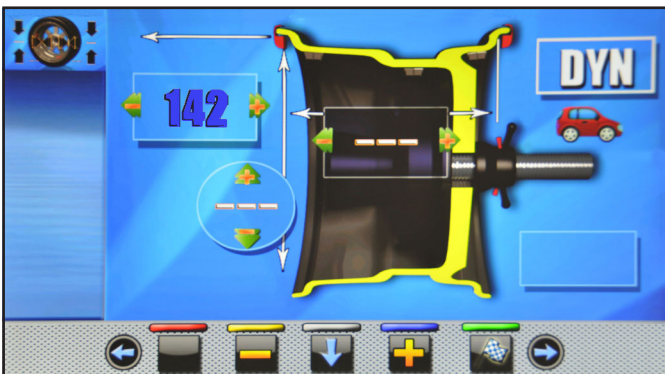

After entering all the required measures, you can spin



the wheel by pressing the button  and closing the protective guard.

NOTE: if the distance-diameter caliper is disabled, the displayed page for detected unbalance is as follows:

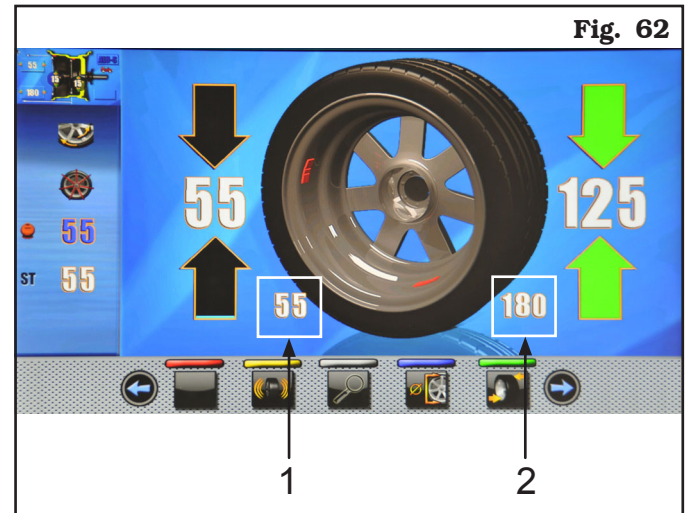

In this screen page, in addition to the information of the detected unbalance, there are measurements in mm at which you must remove the caliper arm (**Fig. 62 ref. 1-2**) to apply the weights inside the rim.

14.7 Standard balancing programs

14.7.1 Static

The STATIC program permits balancing wheels by fitting adhesive weights on the outer and inner sides of the rim. Enter the measurements (see Par. 14.2.1 or 14.6.1) and proceed as described in Par. 14.5.

At the end of the procedure, the wheel balancing conditions can be checked by performing a trial spin.



The procedure has now been completed.

14.7.2 Static-1

STATIC 1 function is a procedure that offsets wheel vibrations using a single weight with clip on a single plane positioned exactly at "12 o'clock".

Enter the measurements (see Par. 14.2.1 or 14.6.1) and proceed as described in Par. 14.5 "Dynamic balancing" (only for wheel inner side).

At the end of the procedure, the wheel balancing conditions can be checked by performing a trial spin.



The procedure has now been completed.

14.7.3 Static-2

STATIC 2 function is a procedure that offsets wheel vibrations using a single adhesive weight on a single plane positioned exactly at "12 o'clock".

Enter the measurements (see Par. 14.2.1 or 14.6.1) and proceed as described in Par. 14.5 "Dynamic balancing" (only for wheel inner side).

At the end of the procedure, the wheel balancing conditions can be checked by performing a trial spin.



The procedure has now been completed.

14.7.4 Dynamic

The DYNAMIC program allows the wheels balancing by fitting two clip adhesive weights: one on the outside and one on the inside rim. Enter the measurements (see Par. 14.2.1 or 14.6.1) and proceed as described in Par. 14.5.

At the end of the procedure, the wheel balancing conditions can be checked by performing a trial spin.

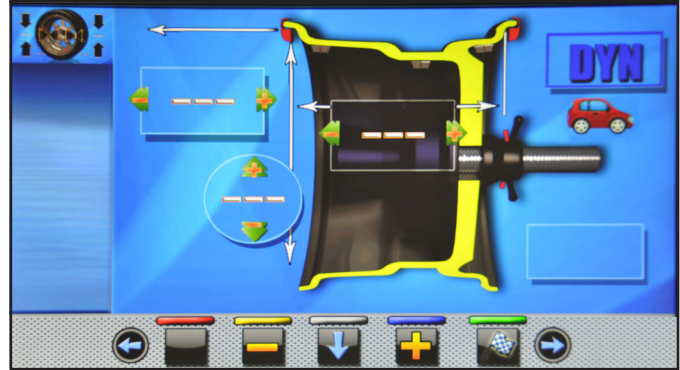

The procedure has now been completed.

14.7.5 ALU-S

ALU-S program permits balancing wheels by two fitting adhesive weights on the outer and inner sides of the rim. Enter the measurements (see Par. 14.2.1 or 14.6.1) and proceed as described in Par. 14.5.

At the end of the procedure, the wheel balancing conditions can be checked by performing a trial spin.



The procedure has now been completed.

14.7.6 ALU-S1

ALU-S1 function permits balancing wheels with light alloy rims by fitting adhesive weights on the outer side and weight with clip on inner side of wheel (at "12 o'clock").

Enter the measurements (see Par. 14.2.1 or 14.6.1) and proceed as described in Par. 14.5 (the inner weight is with clip).

At the end of the procedure, the wheel balancing conditions can be checked by performing a trial spin.



The procedure has now been completed.

14.7.7 ALU-S2

ALU-S2 function permits balancing wheels with light alloy rims by fitting two adhesive weights: one on the outer and one on inner sides of the rim (the inner weight is at 12 o'clock).

Enter the measurements (see Par. 14.2.1 or 14.6.1) and proceed as described in Par. 14.5.

At the end of the procedure, the wheel balancing conditions can be checked by performing a trial spin.



The procedure has now been completed.

14.7.8 ALU-1

ALU-1 function permits balancing wheels with light alloy rims by fitting adhesive weights on the outer and inner sides of the rim at "12 o'clock".

Enter the measurements (see Par. 14.2.1 or 14.6.1) and proceed as described in Par. 14.5.

At the end of the procedure, the wheel balancing conditions can be checked by performing a trial spin.



The procedure has now been completed.

14.7.9 ALU-2

ALU-2 function balances wheels with light alloy rims by fitting adhesive weights on the outside and inside of the rim. The position of the outer weight is not visible but hidden inside. Enter the measurements (see Par. 14.2.1 or 14.6.1) and proceed as for dynamic unbalance.

At the end of the procedure, the wheel balancing conditions can be checked by performing a trial spin.



The procedure has now been completed.



14.7.10 ALU-3

ALU-3 function is a procedure that uses mixed weights to offset wheel unbalance: weight with clip on inner side of wheel, adhesive weight on outer side, not visible because inside the rim.

Enter the measurements (see Par. 14.2.1 or 14.6.1) and proceed as for dynamic unbalance.

At the end of the procedure, the wheel balancing conditions can be checked by performing a trial spin.

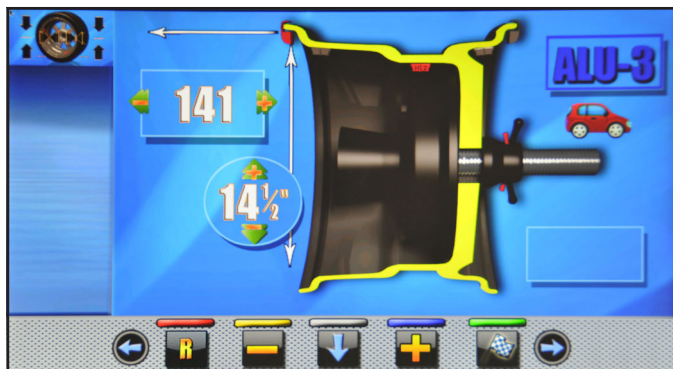

The procedure has now been completed.

14.7.11 ALU-4

ALU-4 function is a procedure that uses mixed weights to offset wheel unbalance: weight with clip on inner side of wheel, adhesive weight on outer side.

Enter the measurements (see Par. 14.2.1 or 14.6.1) and proceed as for dynamic unbalance.

At the end of the procedure, the wheel balancing conditions can be checked by performing a trial spin.



The procedure has now been completed.

14.8 Optional balancing programs

14.8.1 ECO-WEIGHT mode



TO USE THE ECO-WEIGHT PROCEDURE IT IS NECESSARY THAT THE DISTANCE-DIAMETER CALIPER ARM IS ENABLED IN THE "OPTIONS" MENU DESCRIBED IN PAR. 15.1.



THE ECO-WEIGHT PROCEDURE CAN ONLY BE USED WITH THE PROGRAM ALU-S.

This procedure represents a modern system for the reset of the unbalance in order to reduce weights consumption. This procedure ensures a fastest execution of the operations, thanks to a lesser number of spins and repositioning.

After making the wheel spin in ALU-S mode, the monitor shows the total of 2 adhesive weights to precisely correct STATIC and DYNAMIC unbalance.

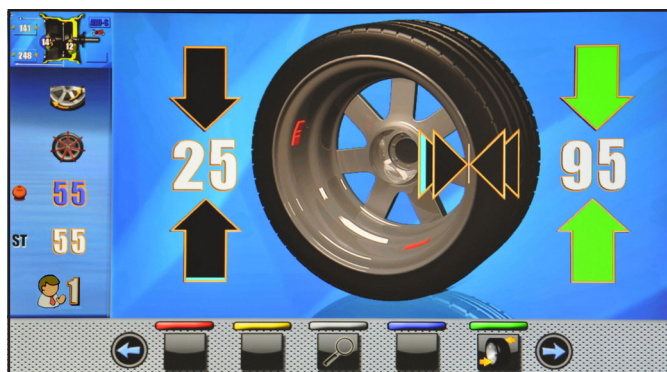

It is possible to fit a single weight at a predetermined distance from the machine, so as to optimize the weight consumption and reduce both the DYNAMIC and any remaining STATIC unbalance as much as possible.

Unlike the standard STATIC procedure, the ECO-WEIGHT procedure, though only using one weight, also considerably reduces the DYNAMIC unbalance, because the fitting distance of the weight on the rim is also calculated.

From ALU-S unbalance results page, if there is con-

siderable static unbalance, press the button  to display on the following monitor screen:



Press button  to select such procedure and bring automatically the wheel into weight fitting position.

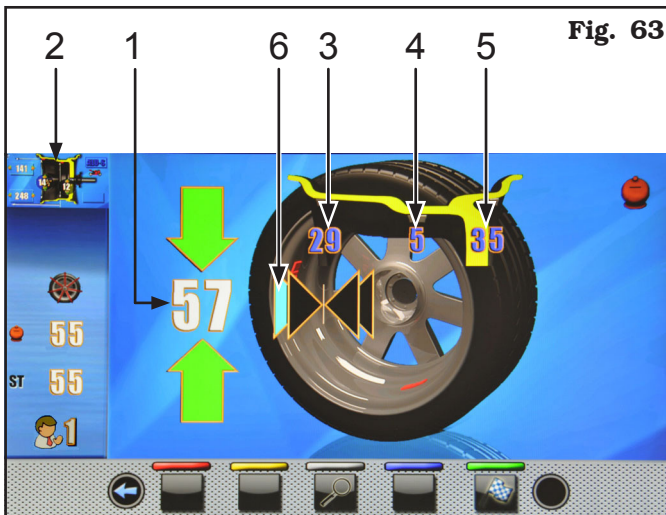

Fig. 63

KEY

- 1 – Only weight to be fitted
- 2 – Last program and last values used for the spin
- 3 – Residual dynamic unbalance value (if the value is blue it is not to carry out ECO-WEIGHT procedure)
- 4 – Static unbalance value (if the value is blue it is not to carry out ECO-WEIGHT procedure)
- 5 – Residual dynamic unbalance value (if the value is blue it is not to carry out ECO-WEIGHT procedure)
- 6 – Arrows indicating the weight fitting point with distance-diameter caliper arm

Press the brake pedal and fit the adhesive weight inside pliers as shown in **Fig. 64**.

Fig. 64

Fit the adhesive weight in the pliers of the gauge rod



Pull out the gauge rod until the arrows (**Fig. 63 ref. 6**) turn green.

Fig. 65

Fit weight on the position where pliers touches the wheel



At the end of the procedure, the wheel balancing conditions can be checked by performing a trial spin. The ECO-WEIGHT procedure has now been completed.



IMMEDIATELY AFTER HAVING SELECTED THE ECO-WEIGHT PROCEDURE, YOU CAN KNOW IN ADVANCE THE TWO DYNAMIC UNBALANCES AND THE STATIC RESIDUE IN ORDER TO DECIDE WHETHER IT IS CONVENIENT TO CONTINUE (SEE FIG. 63). IF BOTH DYNAMIC UNBALANCES AND STATIC RESIDUE ARE SHOWN AS WHITE VALUES ON THE MONITOR, THIS MEANS THAT THE PROGRAM HAS DECIDED THAT IT IS BETTER TO CONTINUE. WHILE IF, ON THE OTHER HAND, ONE OR MORE VALUES ARE BLUE, THE PROGRAM SUGGESTS USING THE STANDARD ALU-S PROCEDURE.

PRESS BUTTON  ONCE, THE TWO RESIDUAL DYNAMIC UNBALANCES WILL BE DISPLAYED ON MONITOR.

PRESS BUTTON  ONCE MORE, THE CALCULATED REAL STATIC WEIGHT AND THE RESIDUAL STATIC WEIGHT WILL BE DISPLAYED ON SCREEN.

IF YOU ARE NOT WISHING TO OPERATE WITH ECO-WEIGHT PRO-

CEDURE, PRESS BUTTON  ONCE MORE, ALU-S UNBALANCE VALUES WILL BE DISPLAYED AGAIN.

WHILE IF YOU WISH TO OPERATE WITH THE ECO-WEIGHT PROCE-

DURE, PRESS BUTTON  FOR

A LONGER TIME (OR KEY ) TO GO BACK TO THE RESIDUAL DYNAMIC/ECO-WEIGHT WEIGHT DISPLAY SCREENS.

14.8.2 SPLIT mode

Split procedure proves useful when the dynamic unbalance of a wheel is fairly high and the weight to be fitted is not available, for instance a 100 g weight. It's possible then to correct the unbalance dividing the amount of weight into two weights of smaller size.

Split procedure eliminates errors by using "DYNAMIC" program, for example by manually fitting two 50 g weights close to one another, instead of only a 100 gr one.

For example:

100 g WEIGHT TO BE FITTED
TO CORRECT UNBALANCE



TWO SMALLER WEIGHTS (50g)
FITTED MANUALLY



TWO SMALLER WEIGHTS (55g)
USING SPLIT PROCEDURE



Proceed to "DYNAMIC" unbalance measurement displaying by performing a standard wheel spin.



Once detected the unbalance values, verify that the machine displays the ability to use the "SPLIT" option



(Fig. 59 ref. 4a). Press button  to shift to the next screen page.



Press button  to enter "SPLIT" function. On the monitor screen will be displayed where you must enter the value of the weights to be fitted.



Press button  to select the outer weight to edit.

Press buttons  or  to increase or decrease the total weight to be fitted.



THE BLUE VALUE INDICATES WHICH VALUE IS ACTIVE AND YOU ARE EDITING.



THE HIGHER THE CHOSEN WEIGHTS VALUE IS, THE MORE THEY WILL BE SPACED.

After choosing the value of the weights to be fitted,

press button  to position the wheel for the application of the 1st clip weight.



THE TWO GREEN ARROWS INDICATE THAT THE WHEEL IS PROPERLY POSITIONED FOR THE APPLICATION OF THE 1ST WEIGHT.

Fit the clip weight of the chosen value at "12 o'clock"

on the outside of the wheel. Press again button  to position the wheel for the fitting of the 2nd clip weight.



Fit the clip weight of the chosen value at "12 o'clock"

on the outside of the wheel. Press button  to highlight the value of the weights to be fitted on the inside of the wheel.



Repeat the above steps for the weights to be fitted inside the wheel.

At the end perform again a checking spin to see that you have applied the weights correctly.

14.8.3 Weights hidden behind spokes mode

Adhesive correction weight positioning may not look attractive on some types of rims. In this case, "weights hidden behind spokes" mode can be used: it splits any correction weight on the outer side into two parts to be hidden behind rim spokes. It can be used in ALU-S mode.

Proceed to ALU-S unbalance measurement displaying by performing a standard wheel spin.



Once detected the unbalance values, verify that the machine displays the ability to use the "spokes" options (Fig. 59 ref. 4b).

Press button  to shift to the next screen page.



Press button  to enter the relevant function. On the monitor the next screen page will be displayed:



Bring any spoke upwards at "12 o'clock" position and
 to confirm and continue.

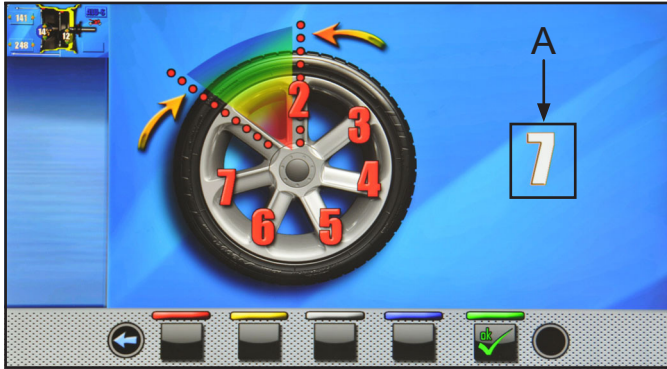

Lead to "12 hours" the 2nd spoke. The machine will automatically calculate the total number of spokes. If the value shown on the screen (A) is correct, press the

The machine automatically calculates weight position in two positions hidden behind the spokes. The monitor shows the amount of weight to be applied behind the FIRST spoke and the rim will reach the position to apply the FIRST weight.



Extract the gauge rod, and fit the FIRST weight in the position shown by the machine, as explained in



Par. 14.5.1. Press the button  to confirm that they have applied the FIRST weight and to automatically position the wheel for the fitting of the 2nd weight. The monitor shows the amount of weight to be applied behind the SECOND spoke.

Pull out the gauge rod and fit the SECOND weight in the position shown by the machine, as done for the first weight.

Press the button  to confirm that you have applied the SECOND weight and get back to the initial situation of unbalance, before performing the "weights hidden behind the spokes" procedure. Perform another test spin. The "weights hidden behind spokes" procedure is completed.

Complete the operation by adding an additional weight inside the rim as required by the selected mode (ALU-S).

14.8.4 Matching mode

The Matching procedure offsets strong unbalance, reducing the weight quantity to be fitted on the wheel to achieve balancing. This procedure permits reducing unbalance as much as possible by offsetting the tyre unbalance with that of the rim in any used program.

Proceed to unbalance measurement displaying by performing a standard wheel spin.

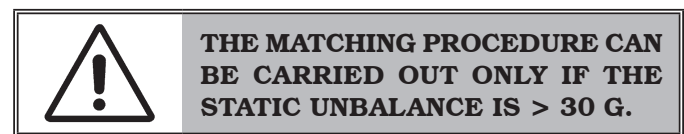

Once detected the unbalance values, verify that the machine displays the ability to use the "matching" options (**Fig. 59 ref. 4a**).

Press button  to shift to the next screen page.



Press button  to enter the relevant function.

On the monitor the next screen page will be displayed:



STEP 1. Move the slider on the flange to the "12 o'clock" position. Make a reference mark, using chalk for instance, on the rim and tyre, in line with the arrow on the flange, so as to be able to fit the rim back on in the same position on the machine.

Make a reference mark on the rim and tyre, in line with the arrow on the flange

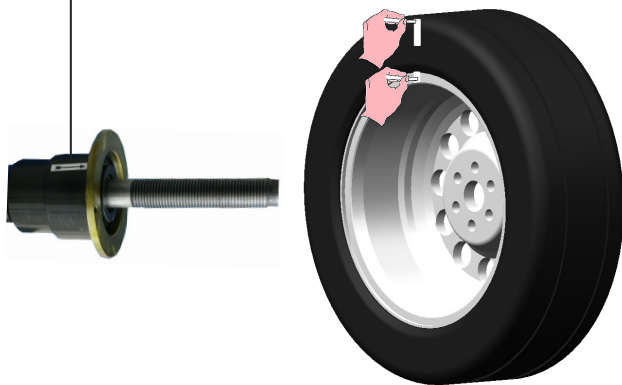

Press button  to confirm that step 1 has been completed.

On the display the next screen page will be displayed:



STEP 2. Remove the wheel from the wheel balancer. Remove the tyre and turn it on the rim through 180°.

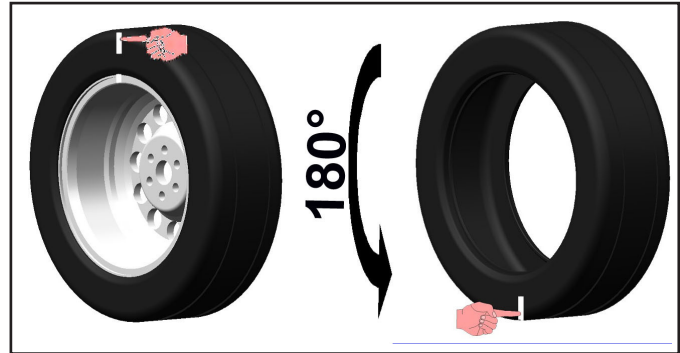

Fit the wheel back on the wheel balancer, positioning the reference mark on the rim in line with the arrow on the flange.

Position the reference mark on the rim in line with the arrow on the flange

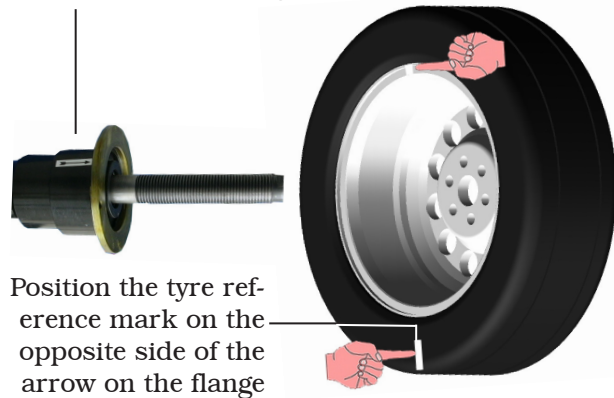

Position the tyre reference mark on the opposite side of the arrow on the flange



Press button  to confirm that step 2 has been completed.

On the display the next screen page will be displayed suggesting to perform a spin of the wheel.



After having fitted wheel back in position, close the protection guard to make an automatic wheel spin. At the end of the spin the monitor will display the following screen:

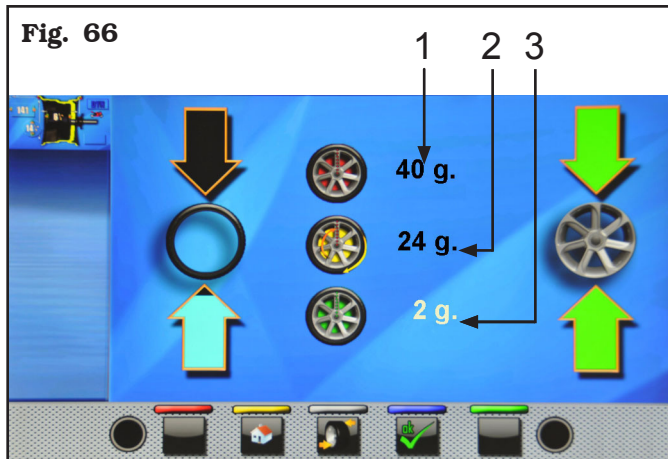

In this screen you will see the dynamic unbalance that the wheel had before performing the operation (**Fig. 66 ref. 1**), the dynamic unbalance after having rotated the tyre through 180° compared to the rim (**Fig. 66 ref. 2**) and the unbalance which can be obtained following the directions of the machine (**Fig. 66 ref. 3**).

STEP 3. If the value of possible unbalance reduction is high, you can proceed as follows:

- Cancel the previously made reference marks. Put new signs, as described below.



- Press the button  to bring the wheel into position.



Make the reference mark on RIM at "12 o'clock" (see **Fig. 67**).

Reference mark on RIM

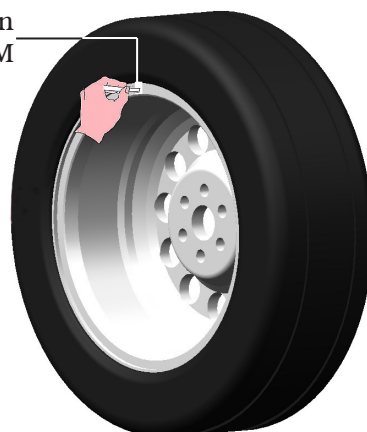



Fig. 67

- Press the button  to bring the wheel into position.



Mark the reference mark on the TYRE at "12 o'clock" position.



- Press button  to confirm that step 3 has been completed.

STEP 4. Remove the wheel from the wheel balancer. Demount and mount the tyre again on the rim so as to bring the two reference marks (rim and tyre) to coincide. Refit the wheel on the balancer (see **Fig. 68**) with the two reference marks next to the arrow on the flange.

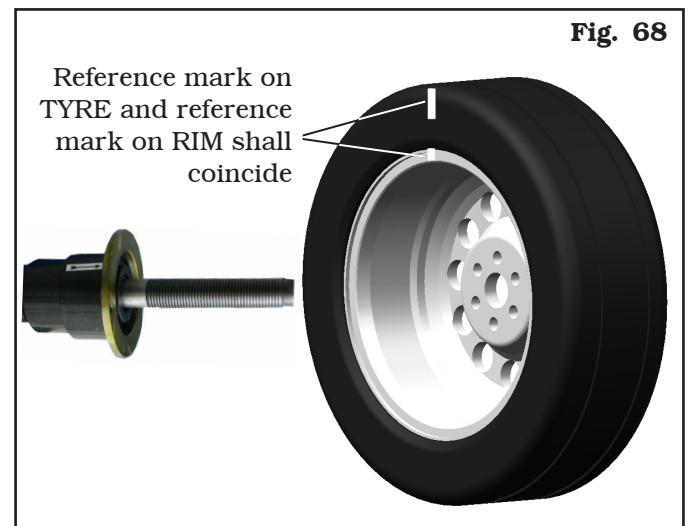

- Press button  to confirm that step 4 has been completed.

Perform another spin closing the protection guard, to check the expected unbalance reduction and correct any residual unbalance, as described in Chap. 14.5.1.



14.9 Special balancing programs

14.9.1 Pax

PAX mode is a special procedure specially devised to balance wheels using the "PAX System ®". 2 adhesive weights on different planes are used on rim inner side.

To launch a PAX measurement, proceed as follows:

- Make sure there are no stones and/or mud on the wheel. Remove any counterweights. Fit the wheel and make sure it is properly fastened (see Chap. 12).

- Press  button from "Home" page. On the screen

that appears, press the button  to switch to measuring mode selection screen below.



Use the arrows  or  to select PAX mode.

At the end press push button . The machine will be configured as follows to perform the measurement and on the video screen will appear the indication of the specific measures of the selected wheel type.

- Close the protection guard to perform the automatic wheel spin.

In just a few seconds, the wheel runs at normal speed and the monitor shows wheel rotation.

After the spin, the wheel stops automatically, taking into account the measured unbalance so that the fitting position of the weight will be at "12 o'clock".



The monitor show the weight required to correct the unbalance.

Open the protection guard and proceed to fit the adhesive weight as shown for the ALU-S mode (see Par. 14.7.5).

14.10 Recalculation function

After making a spin, the wheel automatically stops, indicating the weight/s to be fitted and its/their position. In case the operator does not want the type of wheel balance proposed by the machine (program type, weights size, etc ...), proceed with the re-calculation of the wheel balancing without rerunning the spin of the wheel.

To do this, proceed as described below:

- press the button  to return to the measures detection/program selection page;
- select a new balancing program as indicated in Par. 14.2.2;
- take with the gauge arm the measures required by the selected program;
- press button  to perform the re-calculation. The monitor will display the weights and the positions in which they will be applied.



If also in this case the operator should decide to further modify the balancing program, it is sufficient to proceed as described above without having to spin the wheel.

When the result of the recalculation does not satisfy the operator, it is recommended to do a spin of the wheel to confirm the findings from the operation of recalculation itself.

After the launch of the wheel, the machine, in addition to displaying the unbalance value, draw up automatically all the programs measurement fields that are consistent with those measures that were taken previously and at the same time erases all measures which are not consistent.



**14.11 Wheel balancing in Motorcycle mode
(with distance caliper extension Kit)**

By enabling "motorcycle wheel balancing" function, the wheel balancers can also balance motorcycle wheels. Before detecting the wheel sizes (see Par. 14.2.2), select motorcycle wheel balancing mode proceeding as described below:

press button  and then button . On the

screen that appears, press the button  to switch to programs and measurements acquisition selection screen below.





Use arrows  and/or  to select the mode desired.

At the end press push button .

The machine will be configured as follows to perform the measurement in the desired mode and on the screen will appear an indication showing the measures that will be acquired.

The "motorcycle" mode automatically recalculates the wheel distance measurement, increasing it by the length of the extension supplied with distance caliper extension kit (kit available on demand).

 **THE EXTENSION MUST BE FITTED ONLY WHEN BALANCING IS PERFORMED IN "MOTORCYCLE" MODE.**

 **TO MOUNT THE EXTENSION AND THE COMPONENTS OF CALIPER EXTENSION KIT, PLEASE REFER TO THE SPECIFIC INSTRUCTIONS INCLUDED IN THE KIT.**

Balancing procedures are identical for both modes (car/motorcycle).

By selecting motorcycle mode, besides DYNAMIC balancing (see Par. 14.7.4) STATIC balancing and/or ALU-S (Par. 14.7.1 and/or 14.7.5) can also be performed.

15.0 USER MENU (OPTIONS AND CALIBRATION)

From the main page "Home" press the button 

to move to the next screen page and the button  to access the user menu. On the monitor, the following screen appears where you can enter the password.



The user login password is: **1234**.

After entering the correct password you will see the following screen:

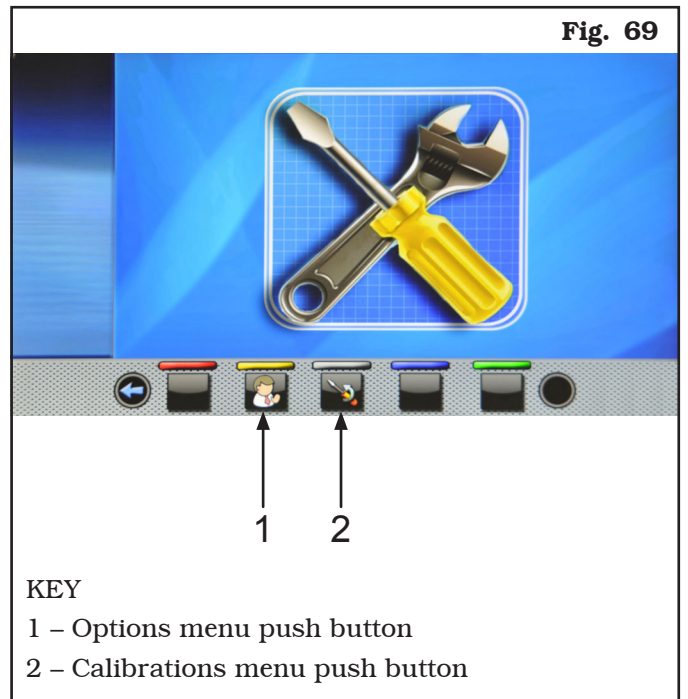

KEY

1 - Options menu push button

2 - Calibrations menu push button



15.1 Options menu





Press button  to display the monitor screen to enable/disable the options as shown below:



To enable / disable individual functions simply high-

light the icon using the buttons  and/or 

and press the button .

Pressing the button  may involve, besides, the change in the unit of measure from "mm" to "inch" and vice versa (where applicable) or access to a sub-screen for values settings values (see Par. 15.1.1 or 15.1.2). After you select/deselect the desired options, exit the

menu by pressing push button .

List of available options



Enable/disable the protection guard/spin (enabled on machine delivery).



Enable/disable the distance/diameter detection caliper (enabled on machine delivery).

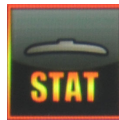

Enable/disable the display of static threshold after each spin (enabled on machine delivery).



It allows you to set the thresholds for each of the balancing mode weights (see Par. 15.1.1).



Enable/disable the lock function for caliper arm in position (disabled on machine delivery).



It allows you to change the unit of measurement of the weights from grams to ounces and vice versa.

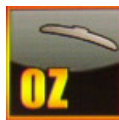

When activated, ounce weight display unit is set. When this option is enabled, weight display unit can be modified from ounces to grams and vice versa (disabled on machine delivery).

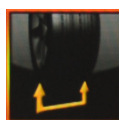

It allows you to enable/disable the width function detected by the external data gauge (enabled when fitted as standard on the machine).



Enable/disable the ECO-WEIGHT function (enabled on machine delivery).

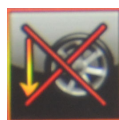

Enable/disable the positioning of weights at "6 o'clock" (disabled on machine delivery).



Enable/disable the pneumatic brake after the spin (disabled on machine delivery).

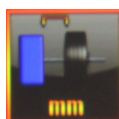

It allows you to change the unit of measure of the distance of the weights fitting point from mm to inches and vice versa.



Enable/disable the led light (enabled if mounted on the machine).



Enable/disable the dynamic residues in the ECO-WEIGHT function (enabled on machine delivery).



Enable/disable the functions of motorcycle balancing (disabled on machine delivery).

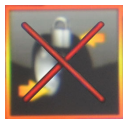

Enable/disable the encoder mounted on the spin motor (disabled on machine delivery).



It allows you to change the unit of measurement of the rims width from mm to inches and vice versa.

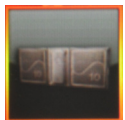

It allows you to set the size values of weights (see Par. 15.1.2).

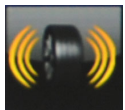

Enable/disable the RUN-OUT functions (enabled on machine delivery).

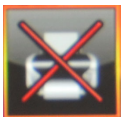

Enable/disable machine print functions (disabled on machine delivery).

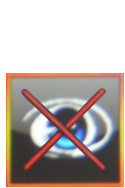

It allows the setting of the retrieval of the measures by eye: readout of measures printed on the rim and the graduated scale of the distance-diameter caliper (disabled on machine delivery).

NOTE: it is activated only if distance-diameter caliper is disabled.

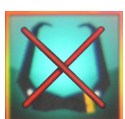

Enable/disable the use of the manual caliper to measure rim width (disabled on machine delivery).
NOTE: it is activated only if distance-diameter caliper is disabled.

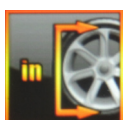

It allows you to change the unit of measurement of the rim diameter from mm to inches and vice versa.

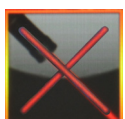

Enable/disable the function of weights positioning laser (disabled on machine delivery).

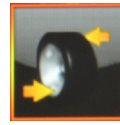

Enable/disable the repositioning of the wheel at the end of the spin (enabled on machine delivery).

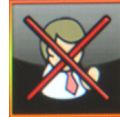

Enable/disable user function (disabled on machine delivery).



Enable/disable the function of weights positioning laser wheel inner/outer side at 12 hours (disabled by default).

15.1.1 Lower weight limit

Correction weight below a certain limit is normally shown equal to zero. This limit can be set from 10 g to 1 g (from 0.5 oz to 0.05 oz).

At the end of the spin however, by pressing the button



, the weight can be displayed with maximum resolution of 1 g (0.05 oz), not considering the set lower limit.



LOWER LIMIT FACTORY SETTING FOR DYNAMIC WHEEL BALANCING MODE IS 5 g (0.25 oz). THE LOWER LIMIT FOR ALL THE OTHER MODES IS SET AT 7 g (0.35 oz).

		Default values		Work range	
		g	oz	g	oz
1		5	0.25	2 ÷ 50	0.05 ÷ 2.00
2		7	0.35	2 ÷ 50	0.05 ÷ 2.00
3		5	0.25	2 ÷ 50	0.05 ÷ 2.00
4		100	100	0 - 50 - 100 150 - 200	0 - 50 - 100 150 - 200
		%		%	

KEY

- 1 - Lower weight limit in the DYNAMIC program to display "OK" (default value 5 g (0.25 oz))
- 2 - Lower weight limit in the ALU-STATIC program to display "OK" (default value 7 g (0.35 oz))
- 2 - Weights display resolution (default value 5 g (0.25 oz))
- 4 - Weight % reduction in ECO-WEIGHT function (0 ÷ 200) (default value 100)

15.1.2 Setting adhesive weight dimensions and static threshold percentage

To ensure the balancing machine precisely calculates the dimensions and total adhesive weights, set the height (thickness) and width of the adhesive weights at your disposal (see **Fig. 70**).

Fig. 70

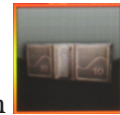
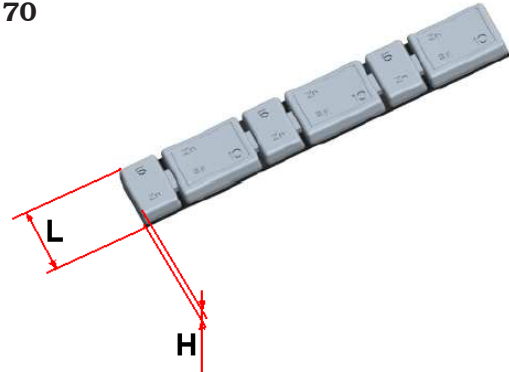

To carry out this setting, press the icon . You will see the following screen:



KEY

- 1 - Weights thickness (height) (default value 4 mm)
- 2 - Weights width (default value 19 mm)

From this screen page, change the size values of weights

using the buttons and .



THE BLUE-COLOURED-VALUE IS THE ACTIVE FIELD AND THE MODIFIABLE ONE.

15.1.3 User management

The "User Management" function is disabled on machine delivery. To enable it, proceed as described in Para 15.1. After enabling, the icon will be displayed on every page (Fig. 71 ref. 1). The wheel balancers can be used simultaneously by 4 different users.



Fig. 71

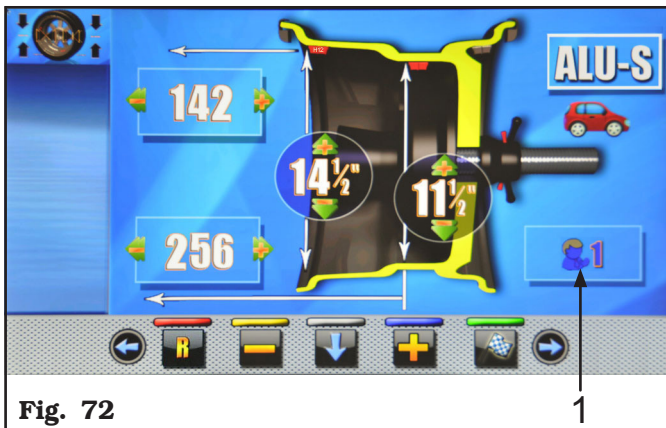



Fig. 72

Press button  shown on the monitor (Fig. 71 ref. 2) or select the field (Fig. 72 ref. 1) and subsequently press the button  to display the screen page below:



KEY



- A – Program used in the last carried out spin
- B – Acquired measurements for the last carried out spin

Press any of the available numbers on the buttons at the bottom of the page to select the corresponding user. The system stores the data relating to the last performed spin according to the different operators. You can recall the desired user each time the program displays the specific button (Fig. 71 ref. 2 and Fig. 72 ref. 1). The measurements stored for each user are lost when the machine is switched off. User management is valid for any wheel balancer function.



TO ENABLE OR DISABLE "USER MANAGEMENT" FUNCTION, SEE PARAGRAPH 15.1. IF THE FUNCTION IS DEACTIVATED, BUTTON  IS DISPLAYED.

15.2 Enabling of electronic Run-out measuring device (optional)

From the main page "Home" press the button  to move to the next screen page and the button  to access the user menu. On the monitor, the following screen appears where you can enter the password.



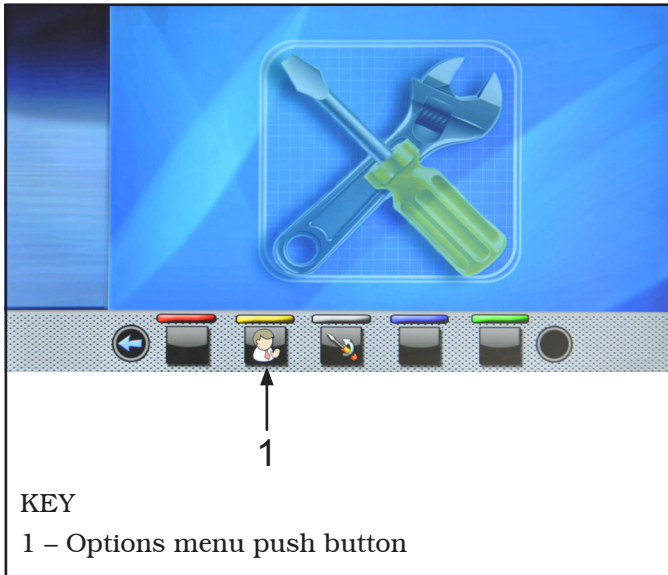

The user login password is: **1234**.

After entering the correct password you will see the following screen:



Press button  to display the monitor screen to enable/disable the options as shown below:



To enable / disable individual functions simply highlight the icon using the buttons  and/or 

and press the button .

After you select/deselect the desired options, exit the menu by pressing push button . Remove symbol "X" on the Run-out icon (**Fig. 73 ref. 1**).

15.3 Machine calibrations



Press the button  (**Fig. 69 ref. 2**) to display the following screen page on monitor:

Fig. 74

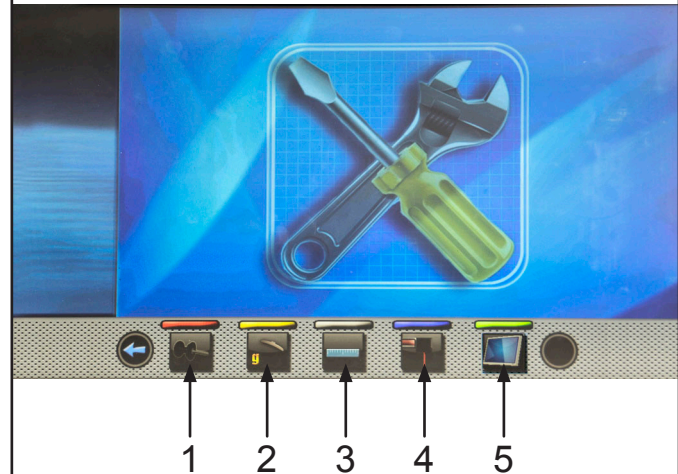

KEY

- 1 – Chuck "0" (zero) calibration
- 2 – Weight measurement sensors calibration
- 3 – Gauges calibration
- 4 – Mobile laser pointer calibration (standard on some models)
- 5 – Touch screen monitor calibration (only for touch screen monitors) (optional)

15.3.1 Chuck "0" (zero) calibration



Press the button (Fig. 74 ref. 1) to display the following screen page on the monitor:

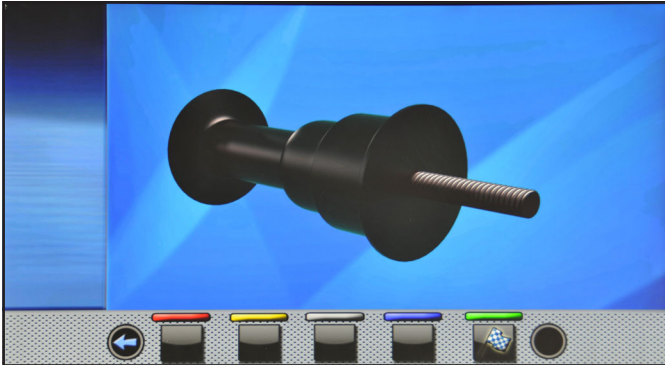

After making sure that the chuck is unloaded (no wheel or mounted accessories) and in the case of closed



pneumatic chuck, press the button and close the guard. The chuck will rotate for a few minutes until you see the screen below:

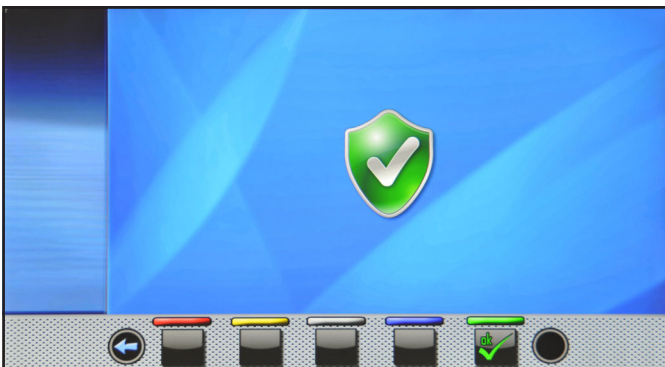

At this point the machine has all its measuring fields.



Press button to return to calibrations screen page.

15.3.2 Weight measurement sensors calibration



ASSEMBLE A BALANCED WHEEL ON THE SPINDLE AND PERFORM THE SPINDLE "0" (ZERO) CALIBRATION PROCEDURE DESCRIBED IN PAR. 15.3.1 (WITH WHEEL MOUNTED).



- Press the button (Fig. 74 ref. 2) to display the following screen page on the monitor:



- Set the size of the rim on the chuck using the distance-diameter caliper arm.
- Set the rim width using one of the following calipers:
 - Manual caliper (supplied with the machine)
 - Wheels width external data gauge (if present)
 - External data gauge/ Run-out (if present)



- Press button and close the guard to perform the 1st spin of the wheel without weights.



IN THE VERSIONS WITH AUTOMATIC WIDTH MEASURING DEVICE, WHEN THE GUARD IS LOWERED, THE RIM WIDTH IS MEASURED AUTOMATICALLY AND THE SIZING SPIN IS CARRIED OUT.

- At the end, on the monitor will appear the following screen, saying that you should apply a weight of 100 g to the "12 o'clock" outer rim.

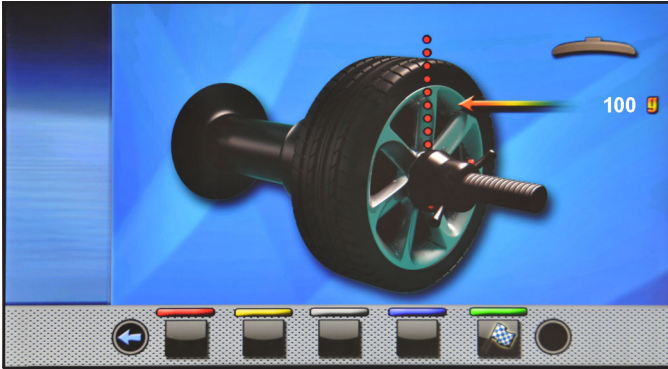

APPLY THE WEIGHT AT A POINT IN WHICH BOTH SIDES OF THE RIM THERE IS THE POSSIBILITY OF APPLYING A CLIP WEIGHT OF 100 g.

- Apply the weight and position it perfectly to the "12 o'clock".



- Press the button  and close the guard to perform the 2nd spin of the wheel (100 g weight placed on the outside of the wheel).
- At the end the following screen will appear on the monitor, suggesting to remove the weight of 100 g previously applied on the outer side and apply it on the inside of the rim.

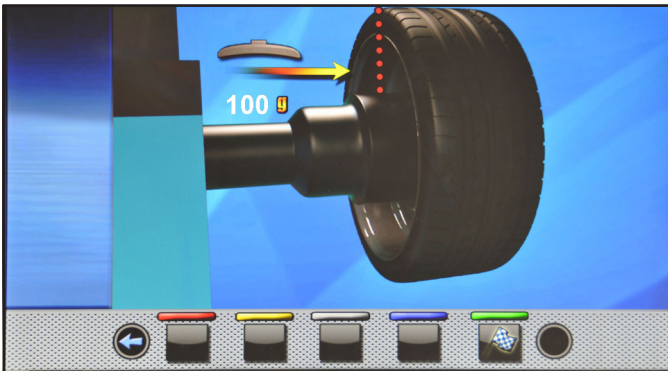

- Turn manually the wheel until You have the weight of 100 g on the outer side at "12 o'clock".
- Press the brake pedal and hold it down during the whole the following operation to avoid unexpected rotation of the spindle.
- Remove the weight from 100 g from the outside of the wheel and apply it on the inner side at "12 o'clock".
- Close the guard to perform the 3rd spin of the wheel (100 g weight placed on the inside wheel).

At the end of the rotation, the video screen below will be displayed to indicate that the operation is finished.



WHEN THE OPERATION IS CONCLUDED, REMOVE THE WHEEL FROM THE CHUCK AND PERFORM A COMPLETE CALIBRATION PROCEDURE "0" (ZERO) CHUCK AS DESCRIBED IN PAR. 15.3.1.

15.3.3 Gauges calibration

Press the button  (Fig. 74 ref. 3) to display the following screen page on the monitor:

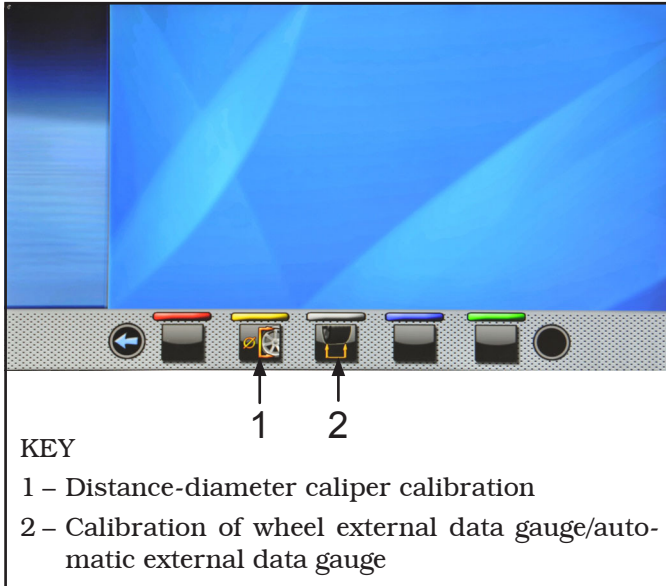

Distance-diameter caliper calibration

Press the button  to display the following screen page on the monitor:



Place the gauge (Fig. 75 ref. 1) on the chuck flange (Fig. 75 ref. 2).

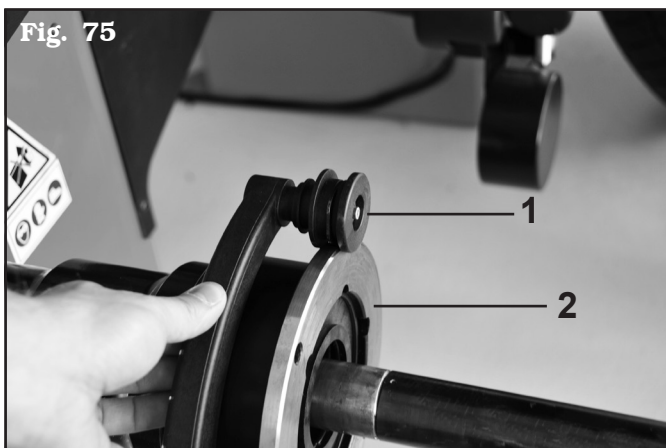

The following screen will appear on the monitor to indicate the measured values:

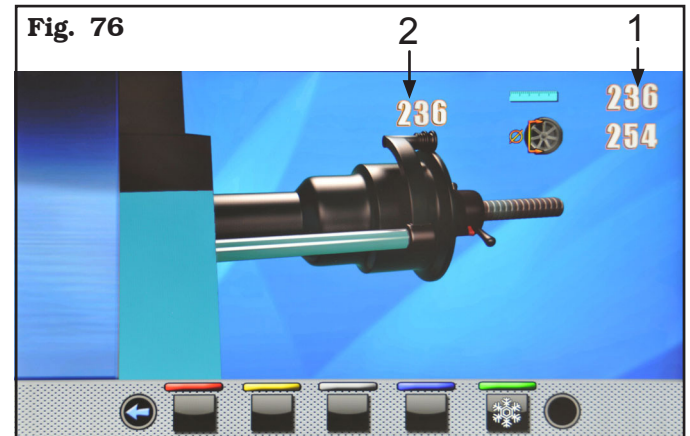

- The value next to the symbol "scale" (Fig. 76 ref. 1) (236 mm for threaded chuck or 256 mm for pneumatic chuck) must be equal to the value positioned above the gauge (Fig. 76 ref. 2) ± 1 mm.





IF THE MEASUREMENT GAUGE IS NOT EXACTLY POSITIONED ALONG THE UPPER EDGE OF THE FLANGE AND CONSEQUENTLY IF THE DISTANCE MEASUREMENT IS NOT 236 MM \pm 1 MM (FOR THREADED CHUCK) OR 256 MM \pm 1 MM (FOR PNEUMATIC CHUCK), WHEN THE MEASUREMENT IS CONFIRMED, THE PROGRAM WILL NOT PASS ON TO THE NEXT STAGE. TRY REPOSITIONING THE GAUGE FERRULE NEXT TO THE UPPER EDGE OF THE FLANGE AND, IF THE MEASUREMENT CONTINUES NOT TO BE BETWEEN 236 MM \pm 1 MM (FOR THREADED CHUCK) OR 256 MM \pm 1 MM (FOR PNEUMATIC CHUCK) AND THE PROGRAM DOES NOT PASS ON TO THE NEXT CALIBRATION STAGE, CONTACT THE AFTER-SALES SERVICE.

- Press push button . The following screen will appear on the monitor:

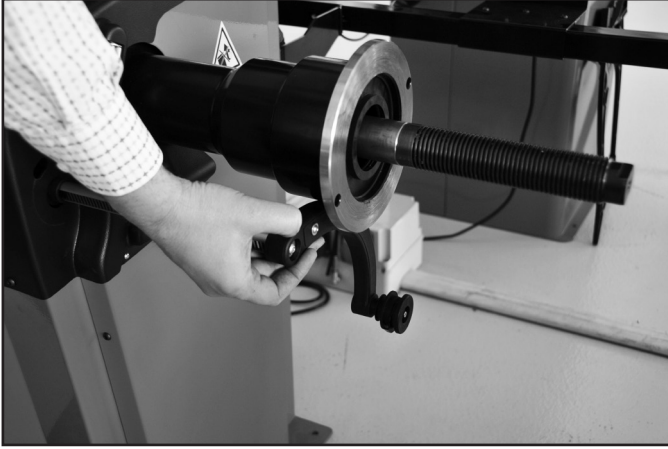

- Place the gauge as shown in the following figure:



- Press push button . Wait a few seconds until you see the following screen:

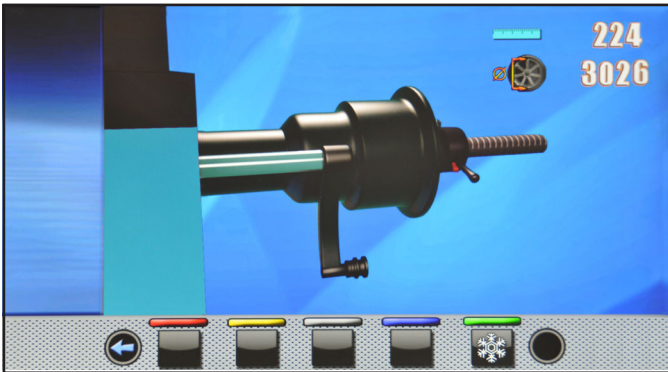

- Place the gauge against the chuck in the lower part of the it but on a smaller diameter than before as indicated on the image on the monitor.



- Press push button . On the monitor the next screen page will be displayed:

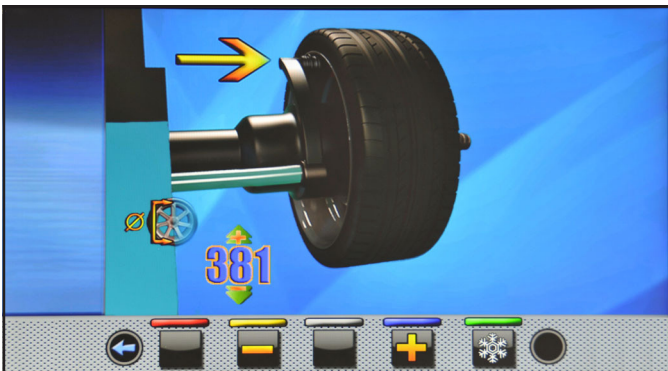

- Measure the exact diameter of a rim (see **Fig. 77**) and place it on the screen on the monitor by pressing the



or



buttons.



Fig. 77

- Fit the measured wheel on the balancer and lock it on the chuck.
- Turn the gauge ferrule (**Fig. 78 ref. 1**) on the inner edge of the wheel upwards (see **Fig. 78**).



Fig. 78



- Press button  to end the operation. On the monitor the next screen page will be displayed:

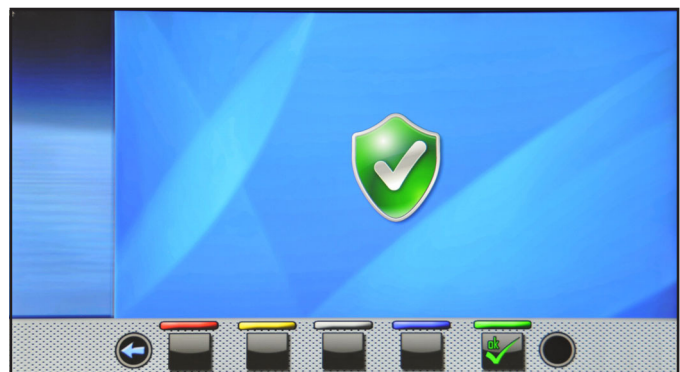

- The calibration of the distance-diameter caliper is finished.

Calibration of external data gauge (standard on some models)



Press the button to display the following screen page on the monitor:

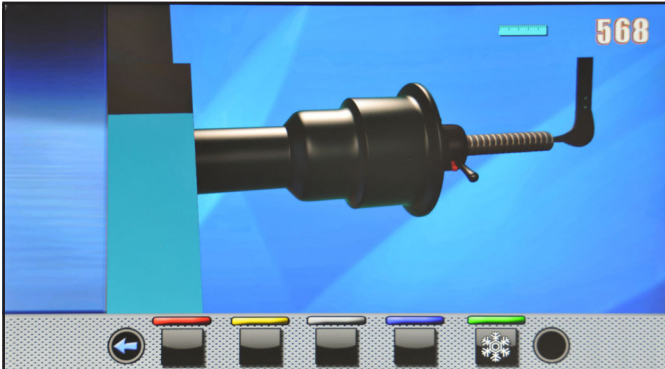

TO PERFORM THIS CALIBRATION, THE CHUCK MUST BE UNLOADED (NO WHEEL OR ACCESSORIES MOUNTED ON IT) AND WITH CLOSED PNEUMATIC CHUCK.

Move the tip of the width measuring device (Fig. 79 - Fig. 80 ref. 1) by the chuck end (Fig. 79 - Fig. 80 ref. 2) (in case of pneumatic chuck, move it next to upper edge of the closed chuck).

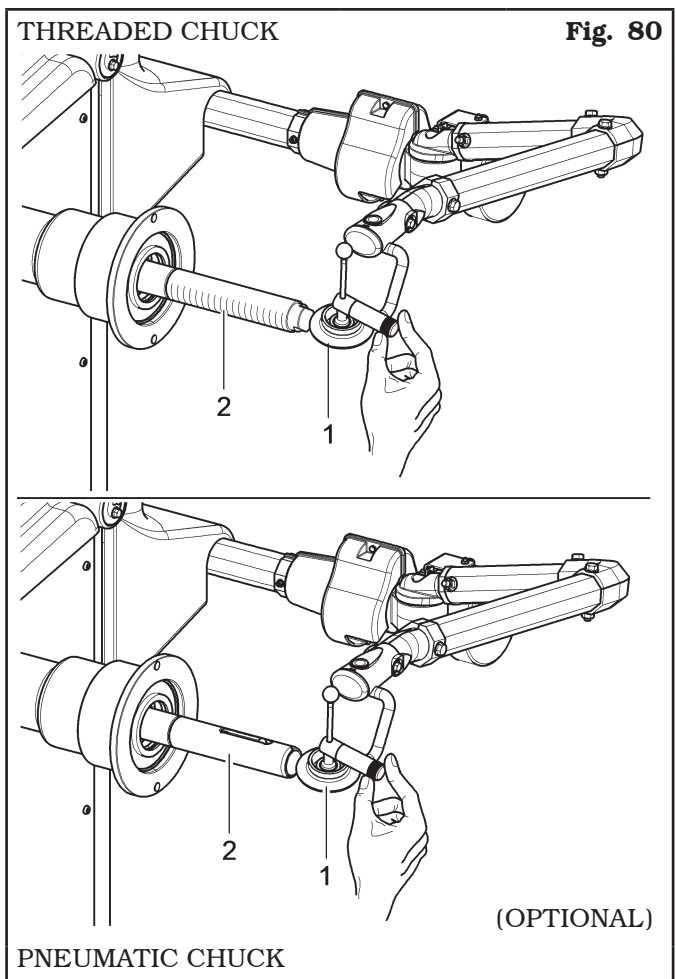
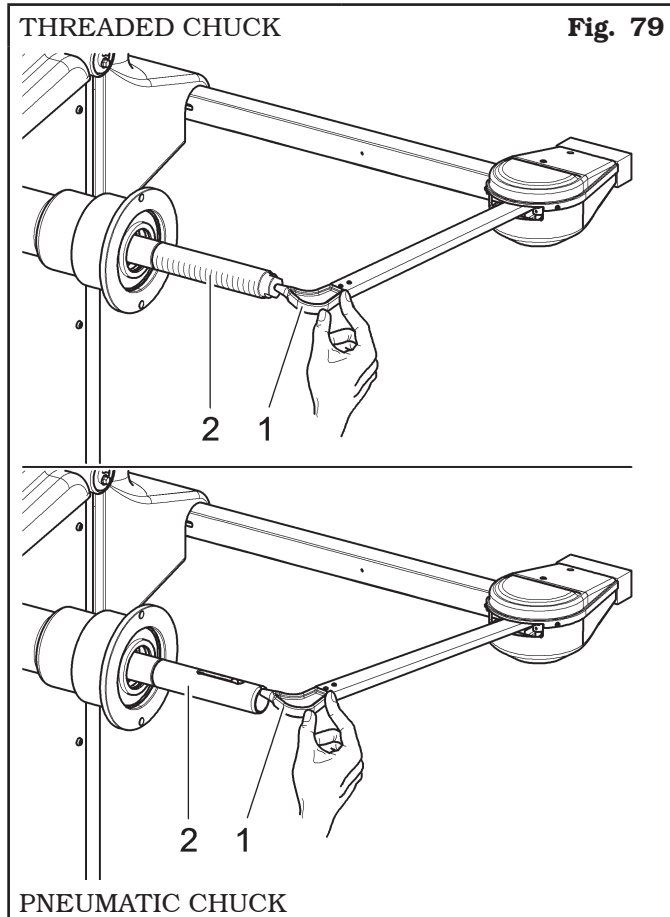

Press button. On the monitor the next screen page will be displayed:

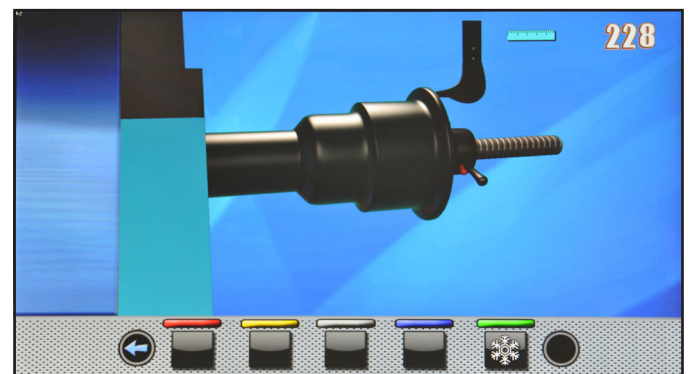

Move the tip of the width measuring device (**Fig. 81 ref. 1**) in line with the outer surface of the flange (**Fig. 81 ref. 2**).

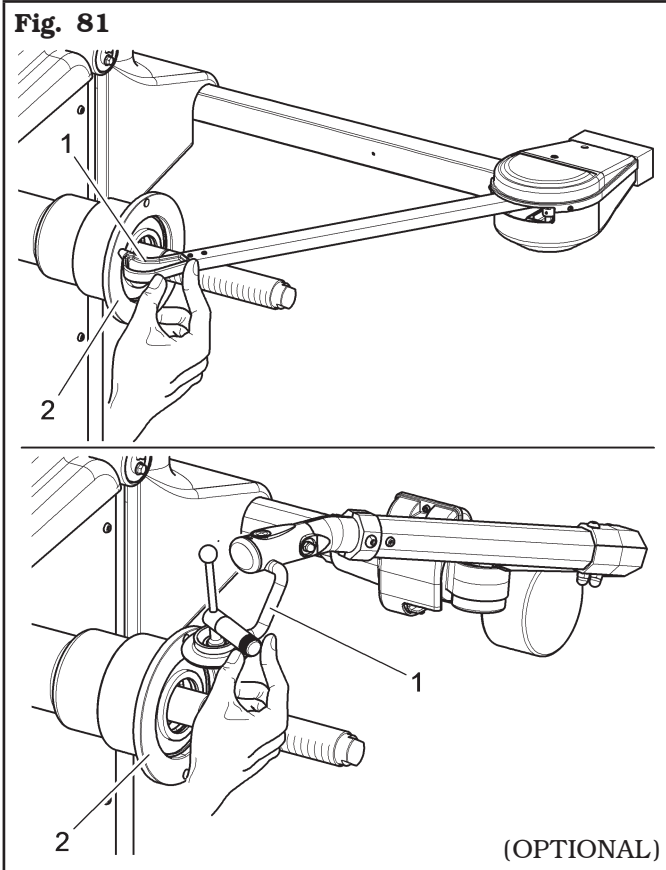

Press button . At the end of the operation, the following screen will appear on the monitor:



The calibration of the external data gauge is finished.

Calibration of automatic width measuring device unit (standard on some models)

Mount the sizing body onto the chuck and fix it through the special locking devices.



Press the button  to display the following screen page on the monitor:

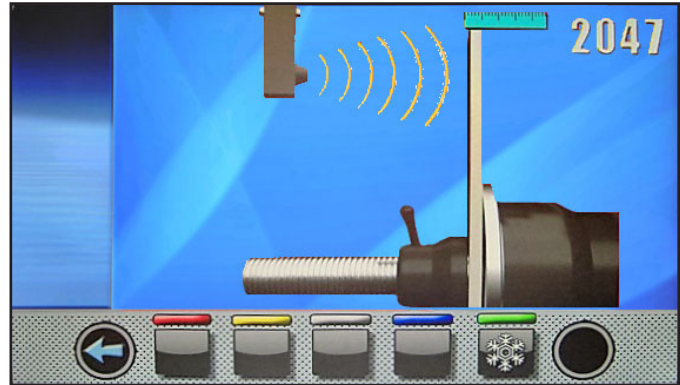

Close the wheel cover until bringing the automatic width sensor next to the sizing body previously installed.



Press button . At the end of the operation, the following screen will appear on the monitor:



The calibration of the automatic external data gauge is finished.

**15.3.4 Mobile laser pointer calibration
(standard on some models)**

To perform this calibration, you need two wheels with a wide rim diameter difference, a small one measuring 13"/14", and a large one measuring 18"/19".

Press the button  (Fig. 74 ref. 4) to display the following screen page on the monitor:



Mount the small wheel (13"/14" diameter) onto the chuck and apply an adhesive weight in any point inside the rim. At the end of the operation press push



button . On the monitor the next screen page will be displayed:



Let the weights fitting gripper of the caliper come into contact with the previously applied weight, by manually rotating the wheel too and taking care to bring it into contact with the weight central area (see Fig. 82).

Fig. 82

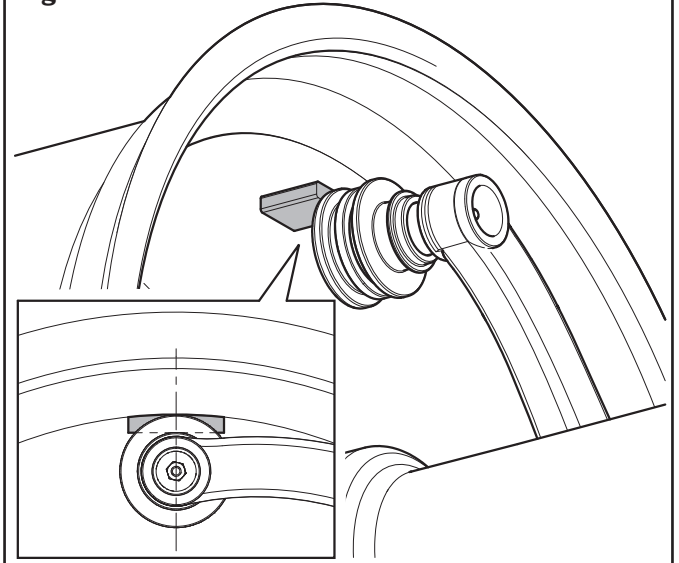

Keep the caliper in position and press push button



. On the monitor the next screen page will be displayed:





Use push button  or  and by manually rotating the wheel too, make the laser pointer hit the reference point previously taken, as showed in Fig. 83.

Fig. 83





When the button is pressed the measure is displayed and the monitor will show the following screen page:

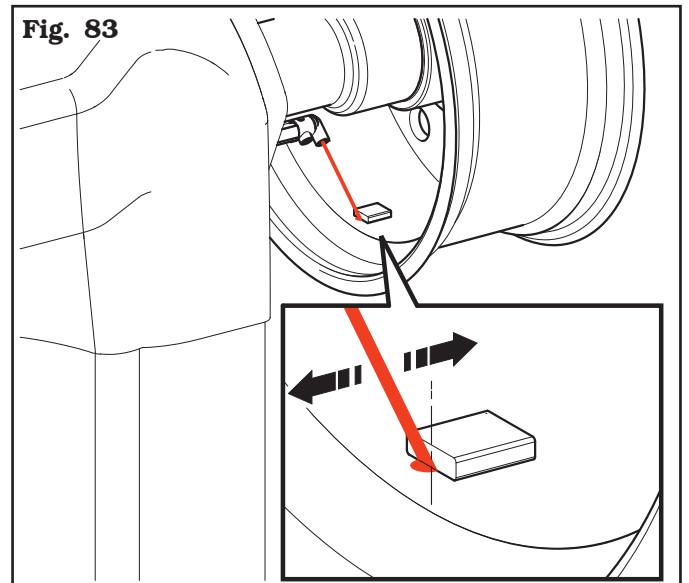

Replace the small wheel (13"/14") with the large one (18"/19") and repeat the previously described operations. At the end of the calibration, the following screen page will be displayed:



The calibration of the laser is finished.

15.3.5 Touch screen monitor calibration (for touch screen monitors) (optional)



Press the button (Fig. 74 ref. 5) to display the following screen page on the monitor:

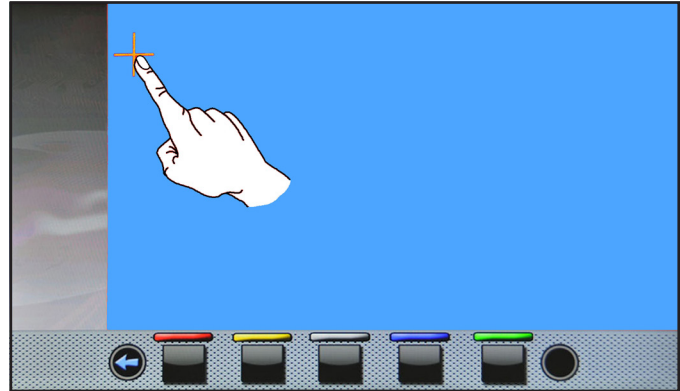

Press the intersection of the lines that appear on the monitor. The points on which you need to press will be 4 and positioned near the corners of the monitor. The calibration of the monitor is finished.

16.0 ERROR SIGNALS

During wheel balancer operation, if wrong commands are given by the operator or device faults occur, an error code may appear on the monitor screen.

Below is a troubleshooting chart.

Error code	Description
2	Planned wheel speed not reached
3	Calibration overcoming
4	Wheel speed stability out of tolerance
5	Encoder calibration error
6	Encoder samples not sufficient
7	Chuck calibration error
8	Piezo calibration values out of tolerance
9	Wheel rotations not completed
10	Pneumatic chuck open
11	Incorrect gain calibration
12	Distance-diameter caliper value not released
13	Distance-diameter caliper value not released
14	Firmware error
15	Runout samples not sufficient
17	External data gauge enabled
27	Rotate the wheel to make a complete rotation
28	Piezo calibration error
29	Distance out of tolerance level
31	Distance-diameter caliper released
32	Parameters format incompatible



17.0 ROUTINE MAINTENANCE



BEFORE CARRYING OUT ANY ROUTINE MAINTENANCE OR ADJUSTMENT PROCEDURE, POSITION THE MAIN SWITCH "0", DISCONNECT THE MACHINE FROM THE ELECTRICITY SUPPLY USING THE SOCKET/PLUG COMBINATION AND CHECK THAT ALL MOBILE PARTS ARE AT A STANDSTILL.



BEFORE EXECUTING ANY MAINTENANCE OPERATION, MAKE SURE THERE ARE NO WHEELS LOCKED ONTO THE CHUCK.



PNEUMATICALLY UNPLUG THE MACHINE (ON MODELS WITH PNEUMATIC CHUCK)

To guarantee the efficiency and correct functioning of the machine, it is essential to carry out daily or weekly cleaning and weekly routine maintenance, as described below.

Cleaning and routine maintenance must be conducted by authorized personnel and according to the instructions given below.

- Remove deposits of tyre powder and other waste materials with a vacuum cleaner.

DO NOT BLOW IT WITH COMPRESSED AIR.

- Do not use solvents to clean the pressure regulator.



ANY DAMAGE TO THE MACHINE DEVICES RESULTING FROM THE USE OF LUBRICANTS OTHER THAN THOSE RECOMMENDED IN THIS MANUAL WILL RELEASE THE MANUFACTURER FROM ANY LIABILITY!!

**18.0 TECHNICAL DATA****18.1 Technical electrical data**

Max. absorbed voltage (W)		200
Power supply	Voltage (V)	110-230
	Phases	1
	Frequency (Hz)	50/60
Rotation speed (rev/min)		< 100

18.2 Technical mechanical data

Balancing precision (g)	1
Rim width (inches)	1.5 ÷ 22
Rim diameter (inches)	10 ÷ 30 (manually up to 34)
Max. wheel diameter (inches)	44
Cycle time (sec)	6
Sound emission level (dBA)	< 70
Max. wheel weight (kg)	80
Recommended air pressure (bar)	8 ÷ 10

	Model with wheel external data gauge	Models with automatic width measuring device	Pneumatic model with automatic width measuring device
Weight (Kg)	155	150	160

18.3 Dimensions

Fig. 84

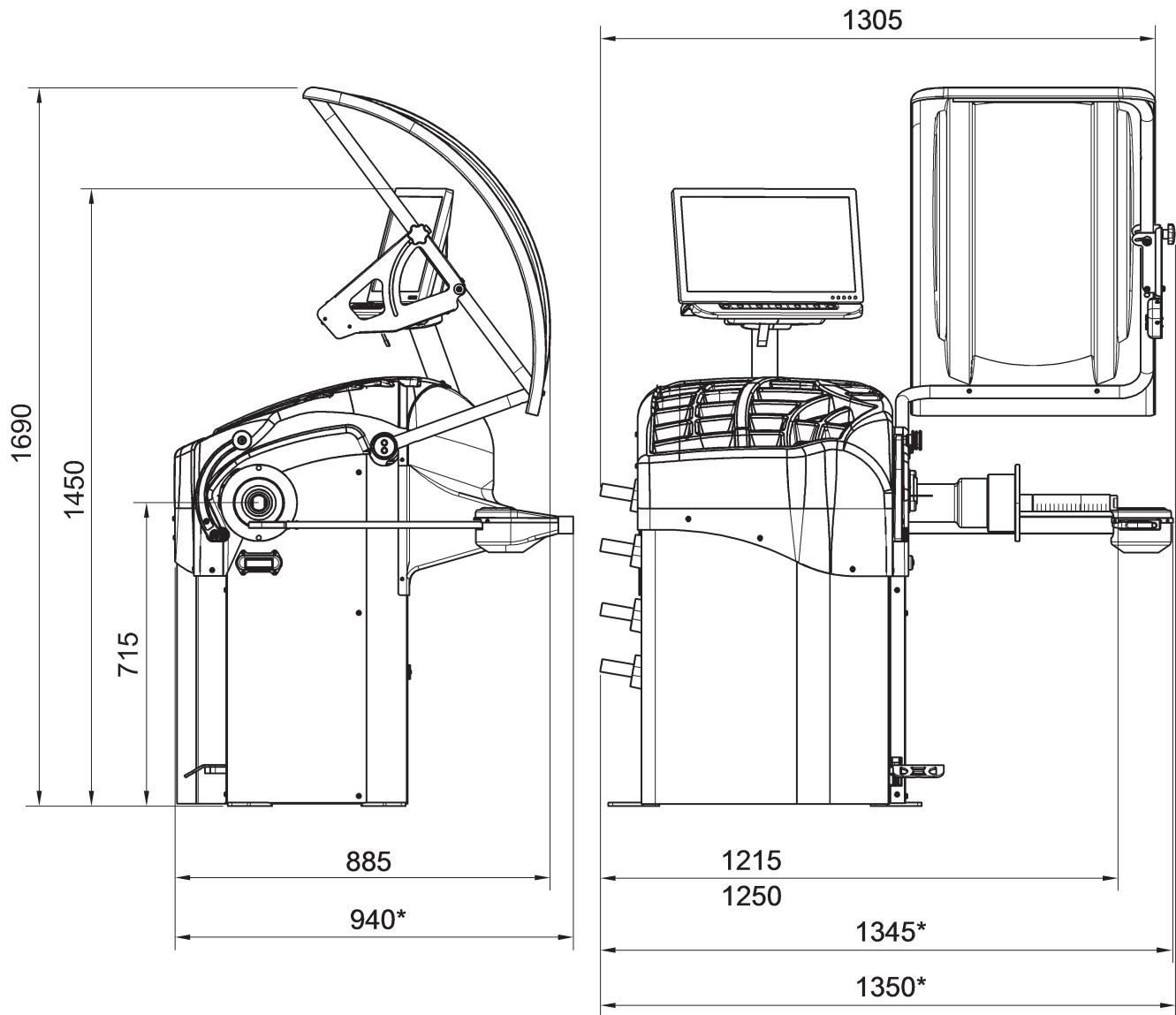

* Standard on some models

19.0 STORING

If storing for long periods disconnect the main power supply and take measures to protect the machine from dust build-up. Lubricate parts that could be damaged from drying out.

20.0 SCRAPPING

When the decision is taken not to make further use of the machine, it is advisable to make it inoperative by removing the connection pressure hoses. The machine is to be considered as special waste and should be dismantled into homogeneous parts. Dispose of it in accordance with current legislation.

Instructions for the correct management of waste from electric and electronic equipment (WEEE) according to the Italian legislative decree 49/14

In order to inform the users on the correct way to dispose the product (as required by the article 26, paragraph 1 of the Italian legislative decree 49/14), we communicate what follows: the meaning of the crossed dustbin symbol reported on the equipment indicates that the product must not be thrown among the undifferentiated rubbish (that is to say together with the "mixed urban waste"), but it has to be managed separately, to let the WEEE go through special operations for their reuse or treatment, in order to remove and dispose safely the waste that could be dangerous for the environment and to extract and recycle the raw materials to be reused.

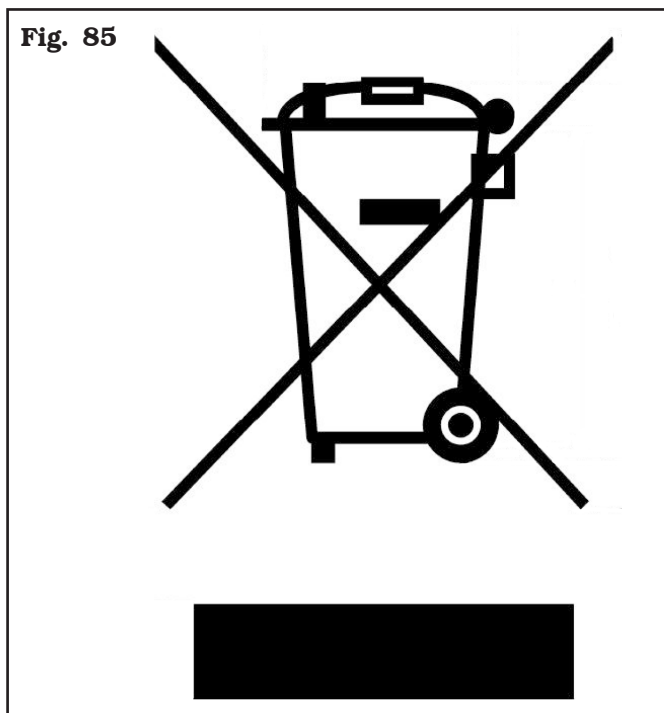

21.0 REGISTRATION PLATE DATA



The validity of the Conformity Declaration enclosed to this manual is also extended to products and/or devices the machine model object of the Conformity Declaration can be equipped with.

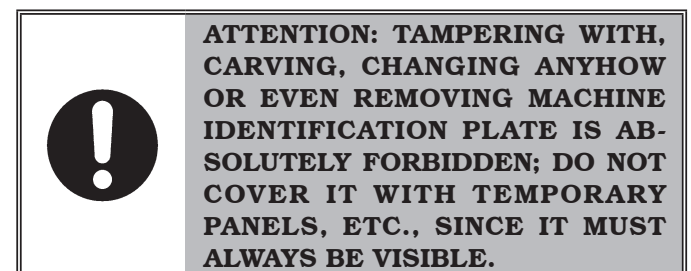

Said plate must always be kept clean from grease residues or filth generally.

WARNING: Should the plate be accidentally damaged (removed from the machine, damaged or even partially illegible) inform immediately the manufacturer.

22.0 FUNCTIONAL DIAGRAMS

Here follows a list of the machine functional diagrams.

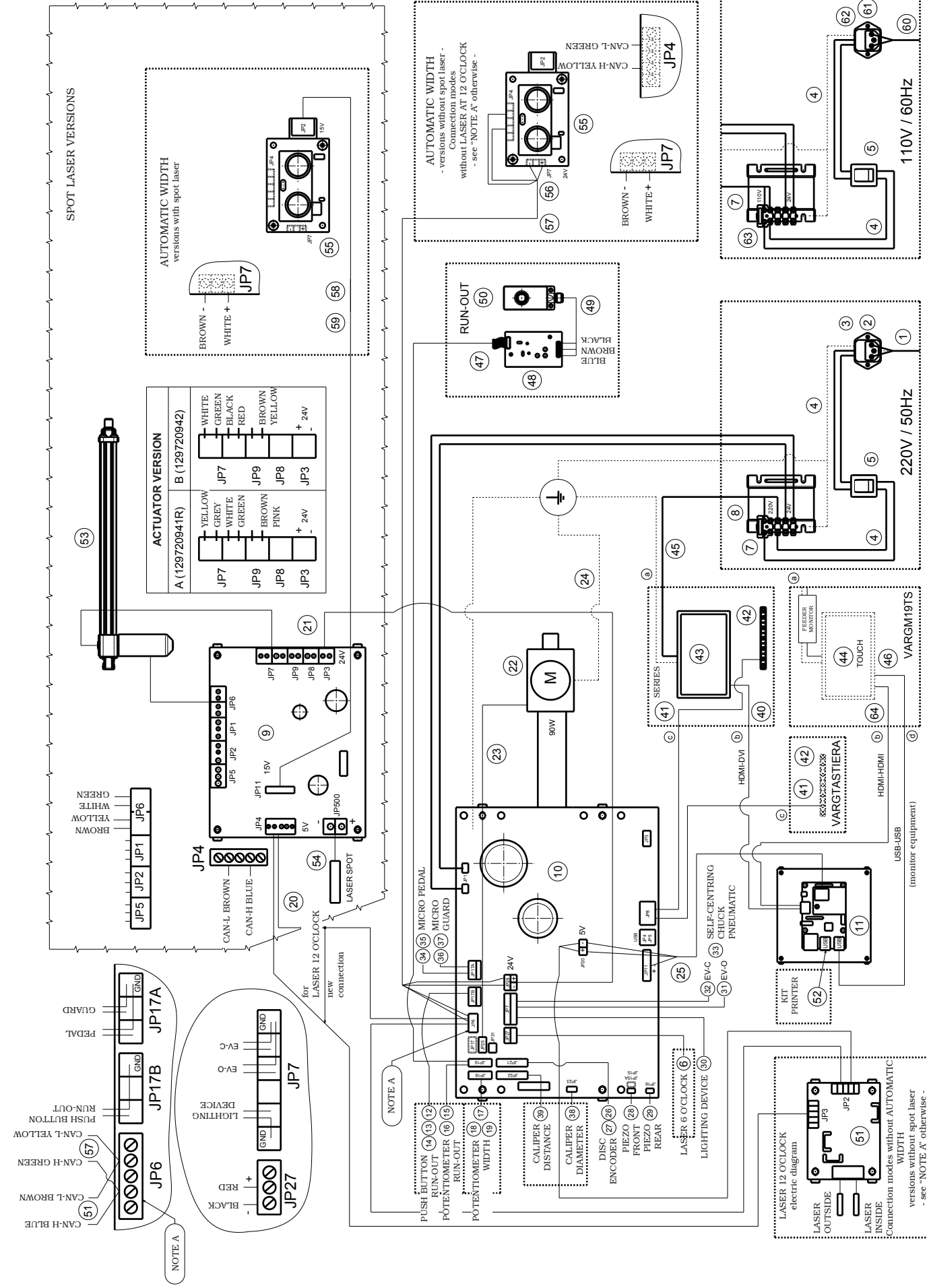

NOTE A
 If 12 O'CLOCK LASER and AUTOMATIC WIDTH, versions without spot laser, should be simultaneously present, CAN-BUS connection (pos. 57) of AUTOMATIC WIDTH must be put into JP2 connector of 12 O'CLOCK LASER card. Strip 200 mm of sheath of cable (pos. 57) (80 mm becomes 200 mm).

G4.140R - G4.140WS - G4.140WSLB - GP4.140WS

**WIRING CONNECTION
 DIAGRAM**

1297-M005-03

KEY

- 1 - Green power supply cable L=2000
- 2 - Net filter
- 3 - Fuse
- 4 - Cable from switch to filter to transformer
- 5 - Tilting switch
- 6 - Line laser (with cable) (for GAR321 and GAR322)
- 7 - Fuse
- 8 - Transformer
- 9 - Automatic measuring device electronics kit
- 10 - Power card kit
- 11 - Monitor SBC kit
- 12 - Run-out push button cables (on GAR303)
- 13 - Run-out keyboard extension cable (on GAR303)
- 14 - Push-button panel with 1 key (on GAR303)
- 15 - Run-out ultrasound sensor cable extension (for GAR303)
- 16 - Potentiometer with cable (on GAR303)
- 17 - Width potentiometer extension cable (on GAR303, GAR305, GAR307)
- 18 - Width cables (on GAR303, GAR305)
- 19 - Potentiometer with shielded cable (on GAR307)
- 20 - Can Bus long extension cable
- 21 - Power supply cable assembly
- 22 - 90W motor with encoder (for versions with laser spot) - DC motor (only versions without spot laser)
- 23 - Motor encoder cable (only versions with laser spot)
- 24 - Motor support ground cable
- 25 - Power supply cable
- 26 - Wheel position sensor cable
- 27 - Buffered encoder board
- 28 - Piezo with front cable
- 29 - Piezo with cable
- 30 - Lighting device
- 31 - Cable for solenoid valve SV-O (only for pneumatic self-centring chuck versions)
- 32 - Cable for solenoid valve SV-C (only for pneumatic self-centring chuck versions)
- 33 - Solenoid valve mounting (only for pneumatic self-centring chuck versions)
- 34 - Cable for pedal micro (only for pneumatic self-centring chuck versions)
- 35 - Limit switch (only for pneumatic self-centring chuck versions)
- 36 - Cable for wheel micro protection
- 37 - Limit switch
- 38 - Potentiometer with cable
- 39 - Buffered optical line board
- 40 - HDMI-DVI cable
- 41 - Push-button panel with 7 keys cables
- 42 - 7-keys keyboard
- 43 - Touch screen monitor 20" HDMI
- 44 - Touch screen monitor 19"
- 45 - Cable from transformer to power supply
- 46 - Cable USB/A - USB/B
- 47 - Ultrasounds sensor extension cable (for GAR315, GAR316, GAR338)
- 48 - Run-out card (for GAR315, GAR316, GAR338)
- 49 - Cable for ultrasounds (for GAR315, GAR316, GAR338)
- 50 - Ultrasounds sensor (for GAR315, GAR316, GAR338)
- 51 - Wiring diagram (for GAR334, GAR335)
- 52 - Printer kit
- 53 - Laser unit actuator
- 54 - Laser cable + laser assembly
- 55 - Ultrasounds sensor card (for wheel balancers with automatic width or GAR332)
- 56 - Width card cable assembly (for wheel balancers with automatic width or GAR332)
- 57 - Extension cable assembly (for wheel balancers with automatic width or GAR332)
- 58 - Serial width card cable assembly (for wheel balancers with automatic width)
- 59 - Serial extension cable assembly (for wheel balancers with automatic width)
- 60 - Power supply cable USA plug
- 61 - Net filter
- 62 - Fuse
- 63 - Fuse
- 64 - HDMI-HDMI cable

 RAVAGLIOLI S.p.A.	WIRING CONNECTION DIAGRAM		1297-M005-03	EN
	Drawing N°A - Rev. 2	129705522	Page 76 of 77	

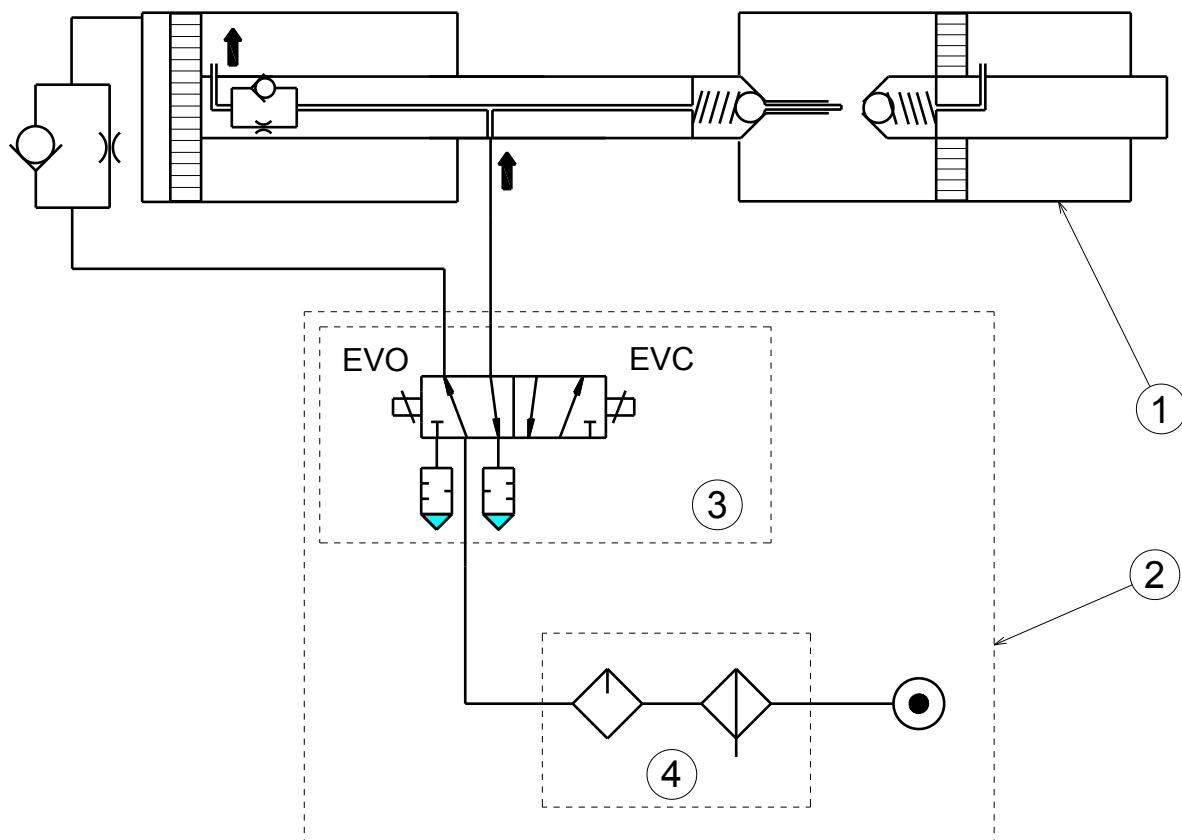

KEY

- 1 - Pneumatic self-centring chuck
- 2 - Pneumatic tightening system
- 3 - Solenoid valve unit
- 4 - Filter mounting

GP4.140WS



RAVAGLIOLI S.p.A.

**PNEUMATIC CONNECTION
DIAGRAM**

Drawing N°B - Rev. 0

129600170

1297-M005-03

Page 77 of 77

EN



Dichiarazione di Conformità

Declaration of Conformity
Konformitätserklärung
Déclaration de Conformité
Declaración de Conformidad



Noi
We / Wir / Nous / Nosotros

RAVAGLIOLI S.p.A.
via 1° Maggio, 3
40037 Pontecchio Marconi (Bologna) – ITALIA

dichiaro sotto la nostra esclusiva responsabilità che il prodotto

declare, undertaking sole responsibility, that the product
erklären unter unserer alleinigen Verantwortung, dass das Produkt
déclarons, sous notre entière responsabilité, que le produit
declaramos bajo nuestra exclusiva responsabilidad, que el producto

Equilibratrice Wheel Balancer Auswuchtmaschine Équilibreuse de roue Equilibradora	
--	--

al quale questa dichiarazione si riferisce, in base alle seguenti Direttive applicabili:

to which this declaration applies in compliance with the following applicable Directives:
auf das sich diese Erklärung bezieht, in nachstehenden anwendbaren Normen entspricht:
objet de cette déclaration est conformance aux Directives applicables suivantes:
al que se refiere esta declaración cumple con las siguientes Normas aplicables:

2006/42/CE
2014/30/UE

Direttiva Macchine
Direttiva Compatibilità Elettromagnetica

Per la conformità alle suddette direttive sono state seguite le seguenti Norme Armonizzate:

To comply with the above mentioned Directives, we have followed the following harmonized directives:
In Übereinstimmung mit o.g. Richtlinien wurden folgende harmonisierte Normen befolgt:
Pour la conformité aux normes ci-dessus, nous avons suivi les normes harmonisées suivantes:
Para la conformidad a las Normas arriba mencionadas, hemos seguido las siguientes normas armonizadas:

UNI EN ISO 12100:2010

Sicurezza del macchinario – Principi generali di progettazione – Valutazione del rischio e riduzione del rischio

CEI EN 60204-1:2006/AC:2010

Sicurezza del macchinario – Equipaggiamento elettrico delle macchine – Parte 1: Regole generali

La persona preposta a costituire il fascicolo tecnico è RAVAGLIOLI S.p.A.

The technical documentation file is constituted by RAVAGLIOLI S.p.A.
Vorgesetzte Rechtsperson für die Erstellung des technischen Lastenheftes ist RAVAGLIOLI S.p.A.
La société RAVAGLIOLI S.p.A. est l'organisme désigné à la présentation de la documentation technique.
RAVAGLIOLI S.p.A. es encargada a la constitución del archivo técnico.

RAVAGLIOLI S.p.A.