





-  CATALOGO RICAMBI
-  SPARE PARTS CATALOGUE
-  ERSATZTEILVERZEICHNIS
-  CATALOGUE PIÈCES DE RECHANGE
-  CATÁLOGO DE RECAMBIOS CATÁLOGO DE RECAMBIOS

0473-R001-0 | Rev. n° 0 (07-2022)

Manuale valido per i seguenti modelli
 This manual is valid for the following models
 Handbuch gültig für die folgenden Modelle
 Manuel valable pour les modèles suivants
 Manual válido para los siguientes modelos

KPX32	RAV.KPX32.198570
KPX32R	RAV.KPX32.198594
KPX32ER	RAV.KPX32.198815
KPX32P	RAV.KPX32.198785
KPX35	RAV.KPX35.199010
KPX35E	RAV.KPX35.199157
KPX35EV	RAV.KPX35.199393
KPX35EEV	RAV.KPX35.198891



KPX32 - KPX35



Ravaglioli

COME ORDINARE UN PEZZO DI RICAMBIO

Per ordinare un pezzo di ricambio occorre fornire al rivenditore autorizzato il **n° di codice** corrispondente, che deve essere ricavato consultando la tavola relativa posta all'interno del manuale ricambi.

La **tavola** (identificata da n° e indice di revisione) deve essere selezionata consultando l'**Indice delle tavole** posto all'inizio del manuale ricambi.

A tale scopo occorre conoscere:

- il **modello** ed il n° di **matricola** della macchina cui il ricambio è destinato (riportati negli appositi campi sulla **targhetta matricola**)
- il gruppo funzionale di cui fa parte il pezzo (facendo riferimento all'Indice figurato posto all'interno del manuale ricambi).

HOW TO ORDER SPARE PARTS

When ordering spare parts, please always indicate the relevant **part number** to the authorised dealer. The number is to be found in the relevant table in the Spare Parts manual.

The **table** (identified by a number and a revision index) must be selected among the ones in the **tables summary** at the beginning of the spare parts manual.

In order to choose the appropriate table, you must know the following:

- **Machine** model and **serial number** (indicated on the **serial number plate**).
- Functional unit to which the part belongs (please refer to the detailed view in the spare parts manual).



ATTENZIONE!

Ai fini di una corretta gestione dei rischi residui sono ricollocati sulla macchina pittogrammi per il rilievo di quelle zone suscettibili di rischio in fase operativa.

Queste indicazioni sono fornite su etichette autoadesive che recano un proprio codice di identificazione.

Importante: nel caso in cui le etichette venissero smarrite o diventassero illeggibili si prega di ordinarle alla casa costruttrice e ricollocarle secondo lo schema riportato (**Tab. 9**).

WARNING!

For a correct handling of residual risks, pictograms are located on the machine to show the areas subject to risk during operation. These indications are supplied on self-sticking labels bearing an identification code.

Important: should the labels be lost or become illegible, please order replacements from the manufacturer and attach them as shown in the diagram (**Tab. 9**).

ACHTUNG!

Für eine korrekte Verhaltensweise bei den noch bestehenden Risiken zeigen Bilderschriftzeichen auf der Ausrüstung an, welche Zonen während des Betriebs Gefahrenquellen darstellen könnten.

Diese Hinweise finden Sie auf Selbstklebeetiketten, die über eine eigene Identifikationscode verfügen.

Wichtig: Bei Verlust oder Unleserlichkeit der Etiketten bestellen Sie diese bitte bei der Herstellerfirma und bringen sie gemäß dem oben aufgeführten Schema an (**Tab. 9**).

ATTENTION!

Pour assurer une gestion correcte des risques résiduels, des pictogrammes sont appliqués sur la machine pour signaler les zones susceptibles de risque en phase de fonctionnement.

Ces informations sont fournies sur des étiquettes autocollantes qui portent chacune un code d'identification.

Important: en cas de perte des étiquettes ou si elles deviennent illisibles, les commander chez le fabricant directement et les appliquer sur la machine en suivant le schéma (**Tab. 9**).

¡ATENCIÓN!

Con el fin de una correcta gestión de los riesgos residuos, están colocados en la máquina pitogramas para el relieve de las zonas suceptibles de riesgo en fase operativa.

Estas indicaciones se abastecen en etiquetas autoadhesivas que tienen un propio código de identificación.

Importante: en el caso que las etiquetas se perdieran o se volvieran invisibles se ruega pedir las a la casa constructora y volverlas a colocar según el esquema indicado (**Tab. 9**).

COMPOSIZIONE DEL MANUALE	COMPOSITION OF MANUAL	ZUSAMMENSETZUNG DER ANLEITUNG	COMPOSITION DE LA NOTICE	COMPOSICIÓN DEL MANUALE
46 pagine (comprese le copertine)	46 pages (including cover pages)	46 Seiten (inkl. Deckblätter)	46 pages (pages de la couverture inludes	46 páginas (incluidas las cubiertas)

INDICE FIGURATO

La consultazione dell'indice figurato e dell'indice delle tavole qui di seguito riportato, permette una rapida individuazione dei principali gruppi che costituiscono le macchine e delle relative tavole per l'ordinazione delle parti di ricambio.

ILLUSTRATED SUMMARY

The figure and the following summary allow quick identification of machine main units and relevant tables for ordering spare parts.

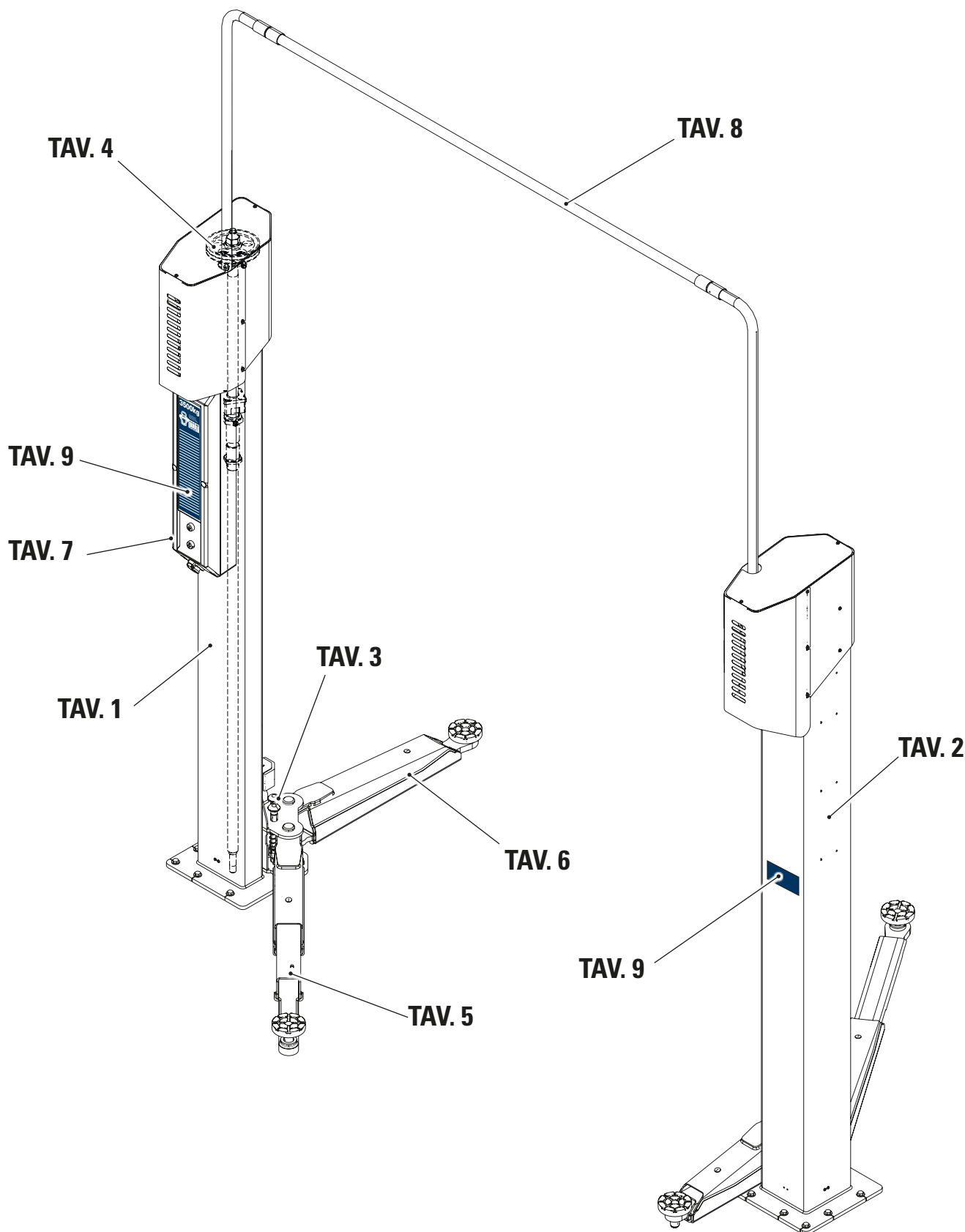

INDICE DELLE TAVOLE – INDEX OF SPARE PARTS TABLES

COLONNA DX CONTROL RH			Valida per i modelli Apply to models							
n° tavola / ind. mod. Table no / change index	Data ultimo aggiornamento. Latest revision made on	N° modifica tecnica Technical change on	KPX32	KPX32R	KPX32ER	KPX32P	KPX35	KPX35E	KPX35EV	KPX35EEV
Matricola di cui è valida la tavola – Starting from serial no.										
1/0	04-08	/	001	001	001	001	001	001	001	001

COLONNA SX LH COLUMN			Valida per i modelli Apply to models							
n° tavola / ind. mod. Table no / change index	Data ultimo aggiornamento. Latest revision made on	N° modifica tecnica Technical change on	KPX32	KPX32R	KPX32ER	KPX32P	KPX35	KPX35E	KPX35EV	KPX35EEV
Matricola di cui è valida la tavola – Starting from serial no.										
2/0	04-08	/	001	001	001	001	001	001	001	001

CERRELLO CARRIAGE			Valida per i modelli Apply to models							
n° tavola / ind. mod. Table no / change index	Data ultimo aggiornamento. Latest revision made on	N° modifica tecnica Technical change on	KPX32	KPX32R	KPX32ER	KPX32P	KPX35	KPX35E	KPX35EV	KPX35EEV
Matricola di cui è valida la tavola – Starting from serial no.										
3/0	04-08	/	001	001	001	001	001	001	001	001

GRUPPO VITE SCREW GROUP			Valida per i modelli Apply to models							
n° tavola / ind. mod. Table no / change index	Data ultimo aggiornamento. Latest revision made on	N° modifica tecnica Technical change on	KPX32	KPX32R	KPX32ER	KPX32P	KPX35	KPX35E	KPX35EV	KPX35EEV
Matricola di cui è valida la tavola – Starting from serial no.										
4/0	04-08	/	001	001	001	001	001	001	001	001

BRACCIO CORTO SHORT ARM			Valida per i modelli Apply to models							
n° tavola / ind. mod. Table no / change index	Data ultimo aggiornamento. Latest revision made on	N° modifica tecnica Technical change on	KPX32	KPX32R	KPX32ER	KPX32P	KPX35	KPX35E	KPX35EV	KPX35EEV
Matricola di cui è valida la tavola – Starting from serial no.										
5A/0	04-08	/	001	NA	NA	001	NA	NA	NA	NA

INDICE DELLE TAVOLE – INDEX OF SPARE PARTS TABLES

BRACCIO CORTO SHORT ARM			Valida per i modelli Apply to models							
n° tavola / ind. mod. Table no / change index	Data ultimo aggiornamento. Latest revision made on	N° modifica tecnica Technical change on	KPX32	KPX32R	KPX32ER	KPX32P	KPX35	KPX35E	KPX35EV	KPX35EEV
Matricola di cui è valida la tavola – Starting from serial no.										
5B/0	04-08	/	NA	NA	NA	NA	001	001	NA	NA

BRACCIO CORTO SHORT ARM			Valida per i modelli Apply to models							
n° tavola / ind. mod. Table no / change index	Data ultimo aggiornamento. Latest revision made on	N° modifica tecnica Technical change on	KPX32	KPX32R	KPX32ER	KPX32P	KPX35	KPX35E	KPX35EV	KPX35EEV
Matricola di cui è valida la tavola – Starting from serial no.										
5C/0	04-08	/	NA	001	001	NA	NA	NA	NA	NA

BRACCIO CORTO SHORT ARM			Valida per i modelli Apply to models							
n° tavola / ind. mod. Table no / change index	Data ultimo aggiornamento. Latest revision made on	N° modifica tecnica Technical change on	KPX32	KPX32R	KPX32ER	KPX32P	KPX35	KPX35E	KPX35EV	KPX35EEV
Matricola di cui è valida la tavola – Starting from serial no.										
5D/0	04-08	/	NA	NA	NA	NA	NA	NA	001	001

BRACCIO LUNGO LONG ARM			Valida per i modelli Apply to models							
n° tavola / ind. mod. Table no / change index	Data ultimo aggiornamento. Latest revision made on	N° modifica tecnica Technical change on	KPX32	KPX32R	KPX32ER	KPX32P	KPX35	KPX35E	KPX35EV	KPX35EEV
Matricola di cui è valida la tavola – Starting from serial no.										
6A/0	04-08	/	001	NA	NA	001	NA	NA	NA	NA

BRACCIO LUNGO LONG ARM			Valida per i modelli Apply to models							
n° tavola / ind. mod. Table no / change index	Data ultimo aggiornamento. Latest revision made on	N° modifica tecnica Technical change on	KPX32	KPX32R	KPX32ER	KPX32P	KPX35	KPX35E	KPX35EV	KPX35EEV
Matricola di cui è valida la tavola – Starting from serial no.										
6B/0	04-08	/	NA	NA	NA	NA	001	001	NA	NA

INDICE DELLE TAVOLE – INDEX OF SPARE PARTS TABLES

BRACCIO LUNGO LONG ARM			Valida per i modelli Apply to models							
n° tavola / ind. mod. Table no / change index	Data ultimo aggiornamento. Latest revision made on	N° modifica tecnica Technical change on	KPX32	KPX32R	KPX32ER	KPX32P	KPX35	KPX35E	KPX35EV	KPX35EEV
Matricola di cui è valida la tavola – Starting from serial no.										
6C/0	04-08	/	NA	NA	NA	NA	NA	NA	001	001

IMPIANTO ELETTRICO ELECTRIC INSTALLATION			Valida per i modelli Apply to models							
n° tavola / ind. mod. Table no / change index	Data ultimo aggiornamento. Latest revision made on	N° modifica tecnica Technical change on	KPX32	KPX32R	KPX32ER	KPX32P	KPX35	KPX35E	KPX35EV	KPX35EEV
Matricola di cui è valida la tavola – Starting from serial no.										
7A/0	04-08	/	001	NA	NA	NA	NA	NA	NA	NA

IMPIANTO ELETTRICO ELECTRIC INSTALLATION			Valida per i modelli Apply to models							
n° tavola / ind. mod. Table no / change index	Data ultimo aggiornamento. Latest revision made on	N° modifica tecnica Technical change on	KPX32	KPX32R	KPX32ER	KPX32P	KPX35	KPX35E	KPX35EV	KPX35EEV
Matricola di cui è valida la tavola – Starting from serial no.										
7B/0	04-08	/	NA	001	NA	NA	001	NA	001	NA

IMPIANTO ELETTRICO ELECTRIC INSTALLATION			Valida per i modelli Apply to models							
n° tavola / ind. mod. Table no / change index	Data ultimo aggiornamento. Latest revision made on	N° modifica tecnica Technical change on	KPX32	KPX32R	KPX32ER	KPX32P	KPX35	KPX35E	KPX35EV	KPX35EEV
Matricola di cui è valida la tavola – Starting from serial no.										
7C/0	04-08	/	NA	NA	001	001	NA	001	NA	NA

IMPIANTO ELETTRICO ELECTRIC INSTALLATION			Valida per i modelli Apply to models							
n° tavola / ind. mod. Table no / change index	Data ultimo aggiornamento. Latest revision made on	N° modifica tecnica Technical change on	KPX32	KPX32R	KPX32ER	KPX32P	KPX35	KPX35E	KPX35EV	KPX35EEV
Matricola di cui è valida la tavola – Starting from serial no.										
7D/0	04-08	/	NA	NA	NA	NA	NA	NA	NA	001

INDICE DELLE TAVOLE – INDEX OF SPARE PARTS TABLES

IMPIANTO ELETTRICO ELECTRIC INSTALLATION			Valida per i modelli Apply to models							
n° tavola / ind. mod. Table no / change index	Data ultimo aggiornamento. Latest revision made on	N° modifica tecnica Technical change on	KPX32	KPX32R	KPX32ER	KPX32P	KPX35	KPX35E	KPX35EV	KPX35EEV
Matricola di cui è valida la tavola – Starting from serial no.										
7E/0	04-08	/	NA	NA	NA	NA	NA	NA	NA	001

IMPIANTO ELETTRICO ELECTRIC INSTALLATION			Valida per i modelli Apply to models							
n° tavola / ind. mod. Table no / change index	Data ultimo aggiornamento. Latest revision made on	N° modifica tecnica Technical change on	KPX32	KPX32R	KPX32ER	KPX32P	KPX35	KPX35E	KPX35EV	KPX35EEV
Matricola di cui è valida la tavola – Starting from serial no.										
7F/0	04-08	/	001	001	001	001	001	001	001	NA

VARIANTI IMPIANTO ELETTRICO ELECTRIC INSTAL. SUNDRY			Valida per i modelli Apply to models							
n° tavola / ind. mod. Table no / change index	Data ultimo aggiornamento. Latest revision made on	N° modifica tecnica Technical change on	KPX32	KPX32R	KPX32ER	KPX32P	KPX35	KPX35E	KPX35EV	KPX35EEV
Matricola di cui è valida la tavola – Starting from serial no.										
8/0	04-08	/	001	001	001	001	001	001	001	001

ADESIVI E TARGHETTE STICKERS AND PLATES			Valida per i modelli Apply to models							
n° tavola / ind. mod. Table no / change index	Data ultimo aggiornamento. Latest revision made on	N° modifica tecnica Technical change on	KPX32	KPX32R	KPX32ER	KPX32P	KPX35	KPX35E	KPX35EV	KPX35EEV
Matricola di cui è valida la tavola – Starting from serial no.										
9/0	04-08	/	001	001	001	001	001	001	001	001

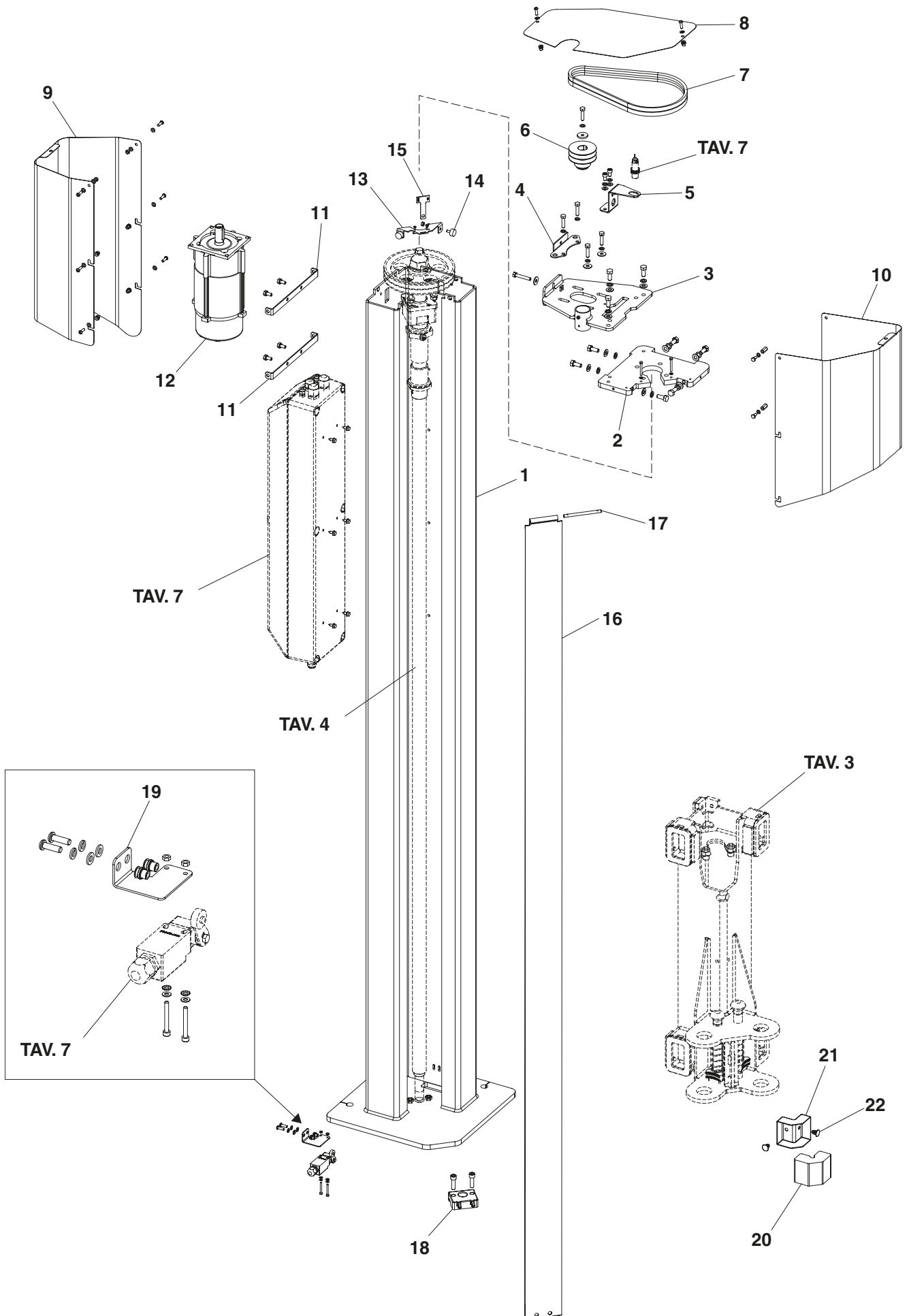

COLONNA DX
CONTROL RH**01** 0

RIF. REF	CODICE CODE	DESCRIZIONE	DESCRIPTION	APPLICAZIONE APPLICATION
1	047320010	COLONNA COMANDO	COMMAND COLUMN	TUTTI I MODELLI ALL MODELS
2	047320041	PIASTRA SUPERIORE COLONNA	COLUMN UPPER PLATE	
3	047318090	PIASTRA MOTORE	MOTOR PLATE	
4	047119070	TENDITORE 90-100-110	TENSIONER 90-100-110	
5	047318140	PIASTRINO PROXIMITY	PROXIMITY PLATE	
6	047318030	PULEGGIA PICCOLA 2 GOLE	SMALL PULLEY 2 GORGES	
7	412216	CINGHIA TRAPEZOIDALE	TRAPEZOIDAL BELT	
8	047318760	COPERTURA CHIUSURA SUPERIORE	TOP CLOSURE COVER	
9	047318800	CARTER COPERTURA POST.COL.DX	RH COLUMN REAR COVER CARTER	
10	047318780	CARTER COPERTURA ANT.COL.DX	RH COLUMN FRONT COVER CARTER	
11	047318740	PIASTRINO PIEGATO SUPP. CARTER	CRANKCASE SUPPORT FOLDED PLATE	
12	900003060	MOTORE 90S4B14 KW2.6-230/400 50/60	MOTOR 90S4B14 KW2.6-230 / 400 50/60	
13	047318130	ANTI ROTAZIONE VASCHETTA	ANTI-ROTATION TRAY	
14	412213	ANTIVIBRANTE	ANTI-VIBRATION	
15	047318810	CALIBRO USURA BUSTA	ENVELOPE WEAR GAUGE	
16	047318060	TENDINA	CURTAIN	
17	047318080	PERNO ATTACCO TENDINA	CURTAIN ATTACHMENT PIN	
18	044518071	SUPPORTO VITE	SCREW SUPPORT	
19	047315440	STAFFA MICRO	MICRO BRACKET	
20	044513060	SALVASPORTELLI	DOORS GUARD	
21	044513070	SUPPORTO SALVASPORTELLI	DOORS GUARD SUPPORT	
22	413157	VITE A PRESSIONE D.9 SERRA	SNAP SCREW D.9	

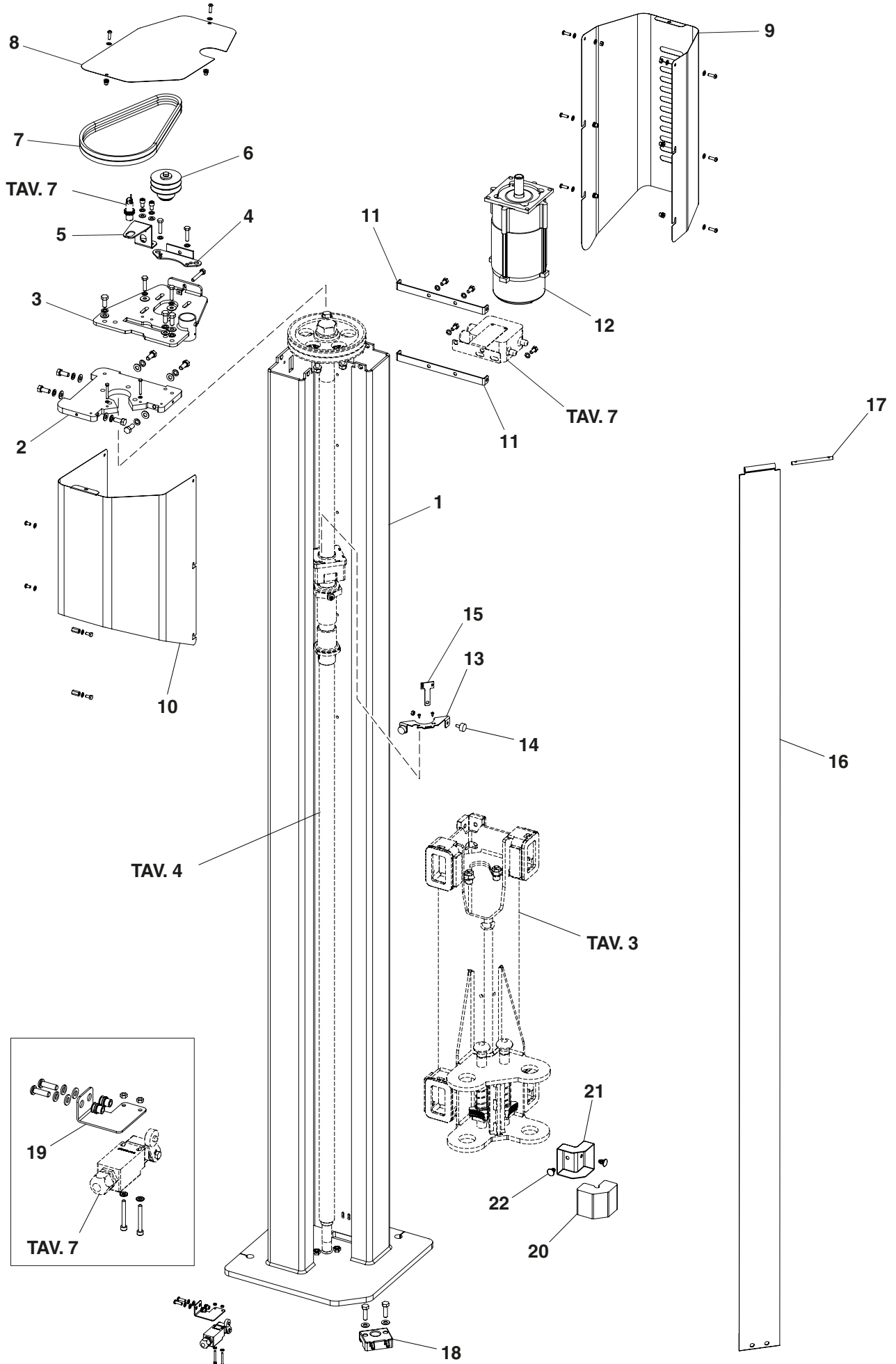

COLONNA SX
LH COLUMN

02 0

RIF. REF	CODICE CODE	DESCRIZIONE	DESCRIPTION	APPLICAZIONE APPLICATION
1	047320010	COLONNA COMANDO	COMMAND COLUMN	TUTTI I MODELLI ALL MODELS
2	047320041	PIASTRA SUPERIORE COLONNA	COLUMN UPPER PLATE	
3	047318090	PIASTRA MOTORE	MOTOR PLATE	
4	047119070	TENDITORE 90-100-110	TENSIONER 90-100-110	
5	047318140	PIASTRINO PROXIMITY	PROXIMITY PLATE	
6	047318030	PULEGGIA PICCOLA 2 GOLE	SMALL PULLEY 2 GORGES	
7	412216	CINGHIA TRAPEZOIDALE	TRAPEZOIDAL BELT	
8	047318760	COPERTURA CHIUSURA SUPERIORE	TOP CLOSURE COVER	
9	047318790	CARTER COPERTURA POST.COL.SX	LH COLUMN REAR COVER CARTER	
10	047318770	CARTER COPERTURA ANT.COL.SX	LH COLUMN FRONT COVER CARTER	
11	047318740	PIASTRINO PIEGATO SUPP. CARTER	CRANKCASE SUPPORT FOLDED PLATE	
12	900003060	MOTORE 90S4B14 KW2.6-230/400 50/60	MOTOR 90S4B14 KW2.6-230 / 400 50/60	
13	047318130	ANTI ROTAZIONE VASCHETTA	ANTI-ROTATION TRAY	
14	412213	ANTIVIBRANTE	ANTI-VIBRATION	
15	047318810	CALIBRO USURA BUSTA	ENVELOPE WEAR GAUGE	
16	047318060	TENDINA	CURTAIN	
17	047318080	PERNO ATTACCO TENDINA	CURTAIN ATTACHMENT PIN	
18	044518071	SUPPORTO VITE	SCREW SUPPORT	
19	047315440	STAFFA MICRO	MICRO BRACKET	
20	044513060	SALVASPORTELLI	DOORS GUARD	
21	044513070	SUPPORTO SALVASPORTELLI	DOORS GUARD SUPPORT	
22	413157	VITE A PRESSIONE D.9 SERRA	SNAP SCREW D.9	

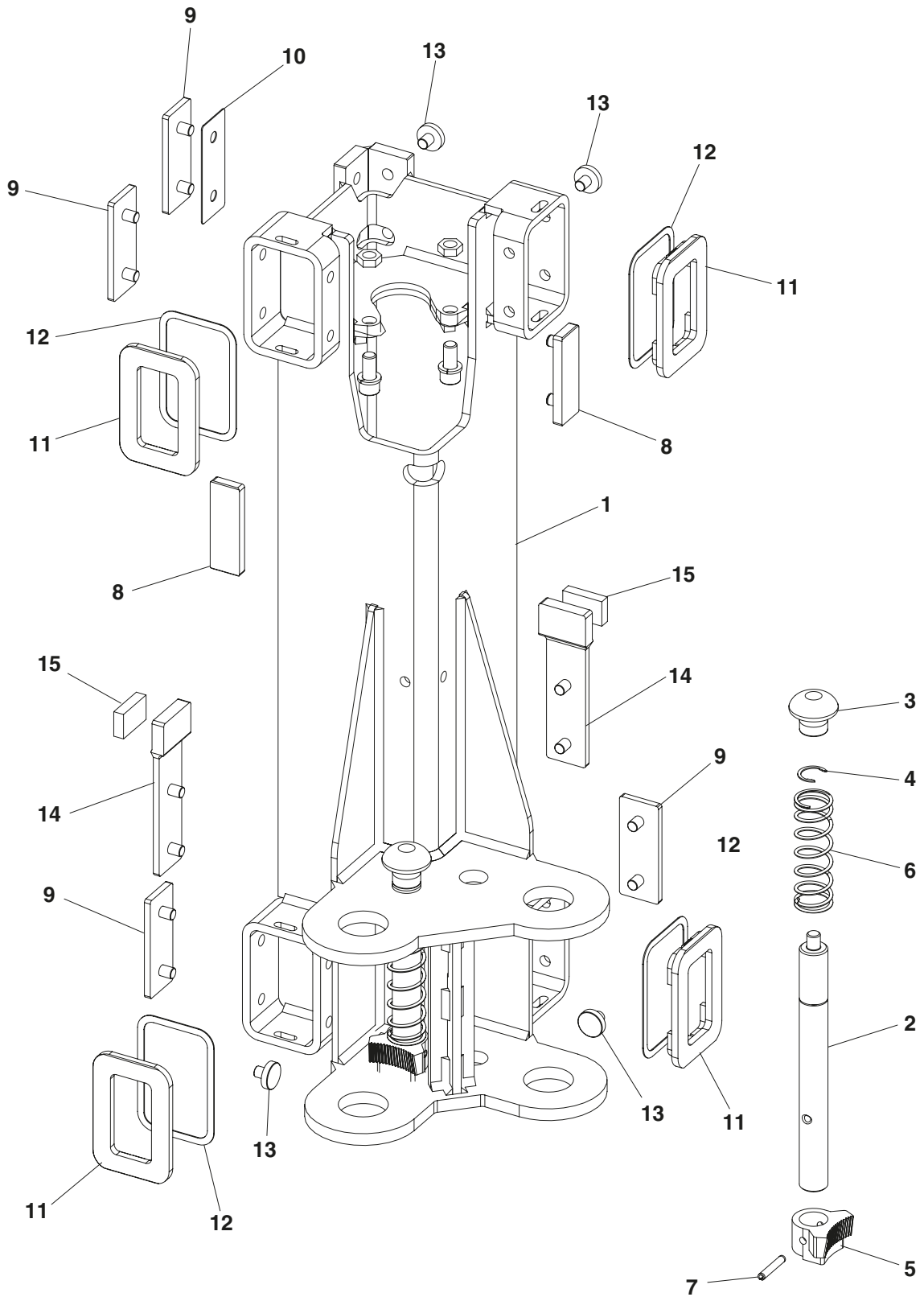

CERRELLO
CARRIAGE**03** 0

RIF. REF	CODICE CODE	DESCRIZIONE	DESCRIPTION	APPLICAZIONE APPLICATION
1	047314010	CARRELLO	CARRIAGE	TUTTI I MODELLI ALL MODELS
2	047318070	PERNO BLOCCO ROTAZIONE BRACCI	ARM ROTATION BLOCK PIN	
3	047319100	POMELLO	KNOB	
4	N119-3	ANELLO DI RITENZIONE	RETENTION RING	
5	N2121	NOTTOLINO DI RITENUTA DEL BRACCIO	ARM RETAINING PAWL	
6	FJ7656-2	MOLLA RITENUTA BRACCIO	ARM RETAINED SPRING	
7	235025	SPINA ELASTICA	ELASTIC SPINE	
8	047318050	PATTINO POSTERIORE	REAR SLIDING SHOE	
9	047019080	PATTINO POSTERIORE	REAR SLIDING SHOE	
10	047319080	SPESSORE PATTINI	SLIDING SHOE THICKNESS	
11	047318040	PATTINO	SLIDING SHOE	
12	047318160	SPESSORE PATTINO	SLIDING SHOE THICKNESS	
13	047221560	PATTINO APPOGGIO LATERALE	LATERAL SUPPORT SLIDING SHOE	
14	047019360	PATTINO PORTAFELTRO	FELT HOLDER SLIDING SHOE	
15	047019370	FELTRO POSTERIORE	REAR FELT	

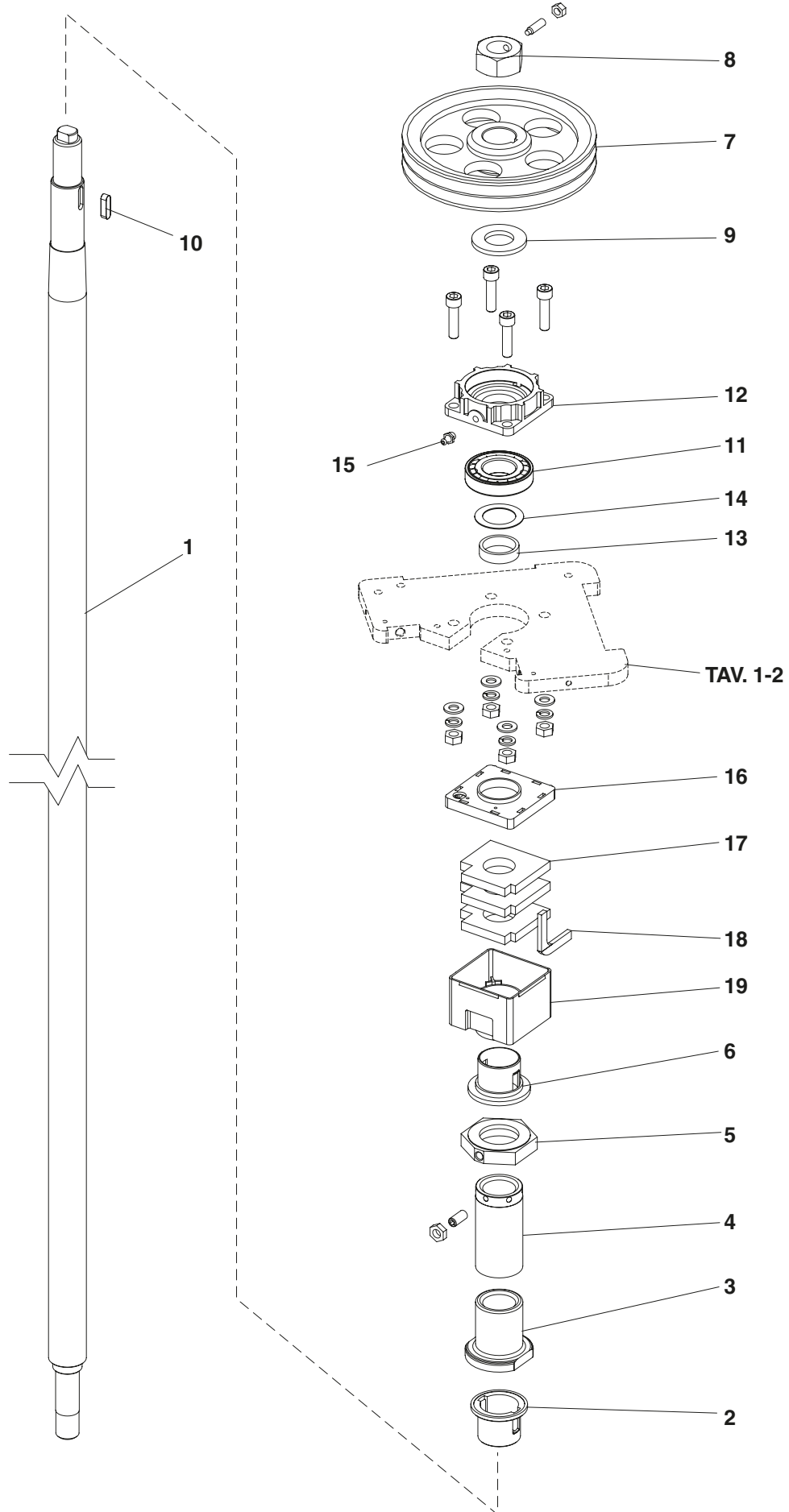

GRUPPO VITE
SCREW GROUP

04 0

RIF. REF	CODICE CODE	DESCRIZIONE	DESCRIPTION	APPLICAZIONE APPLICATION
1	047318010	VITE 40x5	SCREW 40x5	TUTTI I MODELLI ALL MODELS
2	047018640	BOCCOLA DI GUIDA VITE	SCREW GUIDE BUSH	
3	047318220	CONTROBUSTA	STRIKE	
4	047315800	CHIOCCIOLA PORTANTE	BEARING NUT	
5	047318560	ANELLO APPOGGIO CARRELLO	CARRIAGE SUPPORT RING	
6	047318950	BOCCOLA GUIDA VITE	SCREW GUIDE BUSH	
7	047318020	PULEGGIA	PULLEY	
8	047018331	DADO SUPERIORE VITE	UPPER NUT SCREW	
9	236040	RONDELLA PIANA 31x58x5	FLAT WASHER 31x58x5	
10	231047	CHIAVETTA	KEY	
11	607504	CUSCINETTO	BEARING	
12	047018540	SUPPORTO CUSCINETTO CONICO	TAPERED BEARING SUPPORT	
13	047018340	RONDELLA DISTANZIALE	SPACER WASHER	
14	237402	RONDELLA DI SPESSORAMENTO	SHIM WASHER	
15	299097	INGRASSATORE DIRITTO M8	STRAIGHT GREASER M8	
16	044518170	COPERCHIO VASCHETTA	TANK COVER	
17	044518180	FELTRO	FELT	
18	047018630	STOPPINO	WICK	
19	044518160	VASCHETTA DI LUBRIFICAZIONE	LUBRICAT. TANK	

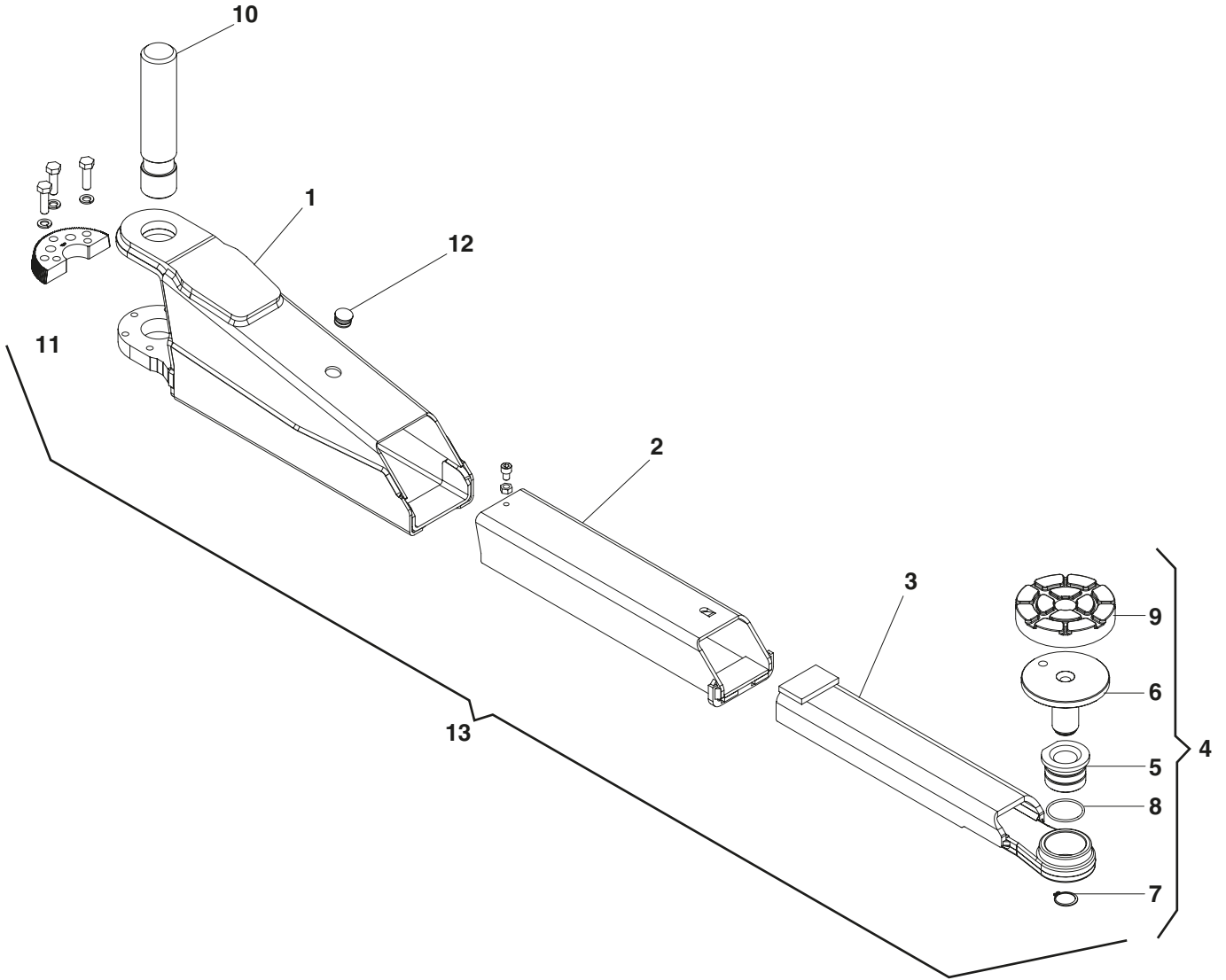

BRACCIO CORTO
SHORT ARM

05A 0

RIF. REF	CODICE CODE	DESCRIZIONE	DESCRIPTION	APPLICAZIONE APPLICATION
1	047310350	CORPO BRACCIO CORTO	SHORT ARM BODY	TUTTI I MODELLI ALL MODELS
2	047310360	PRIMA PROLUNGA	1st EXTENSION	
3	047311270	SECONDA PROLUNGA	2nd EXTENSION	
4	047390410	MTG TAMPONE	STOPPER	
5	047318150	BOCCOLA FILETTATA M33	THREADED BUSHING	
6	048417190	PIATTELLO	PLATE	
7	243015	SEEGER EST.27	SEEGER EST.27	
8	401051	GUARNIZIONE OR	GASKET OR	
9	047305020	TAMPONE D.125	STOPPER Ø125	
10	N2154	PERNO BRACCIO	ARMS PIN	
11	N2122	RUOTA DENTATA ARRESTO BRACCI	ARM STOP GEAR WHEEL	
12	413166	TAPPO	PLUG	
13	047390150	MTG. BRACCIO CORTO	ARM FIXTURE	

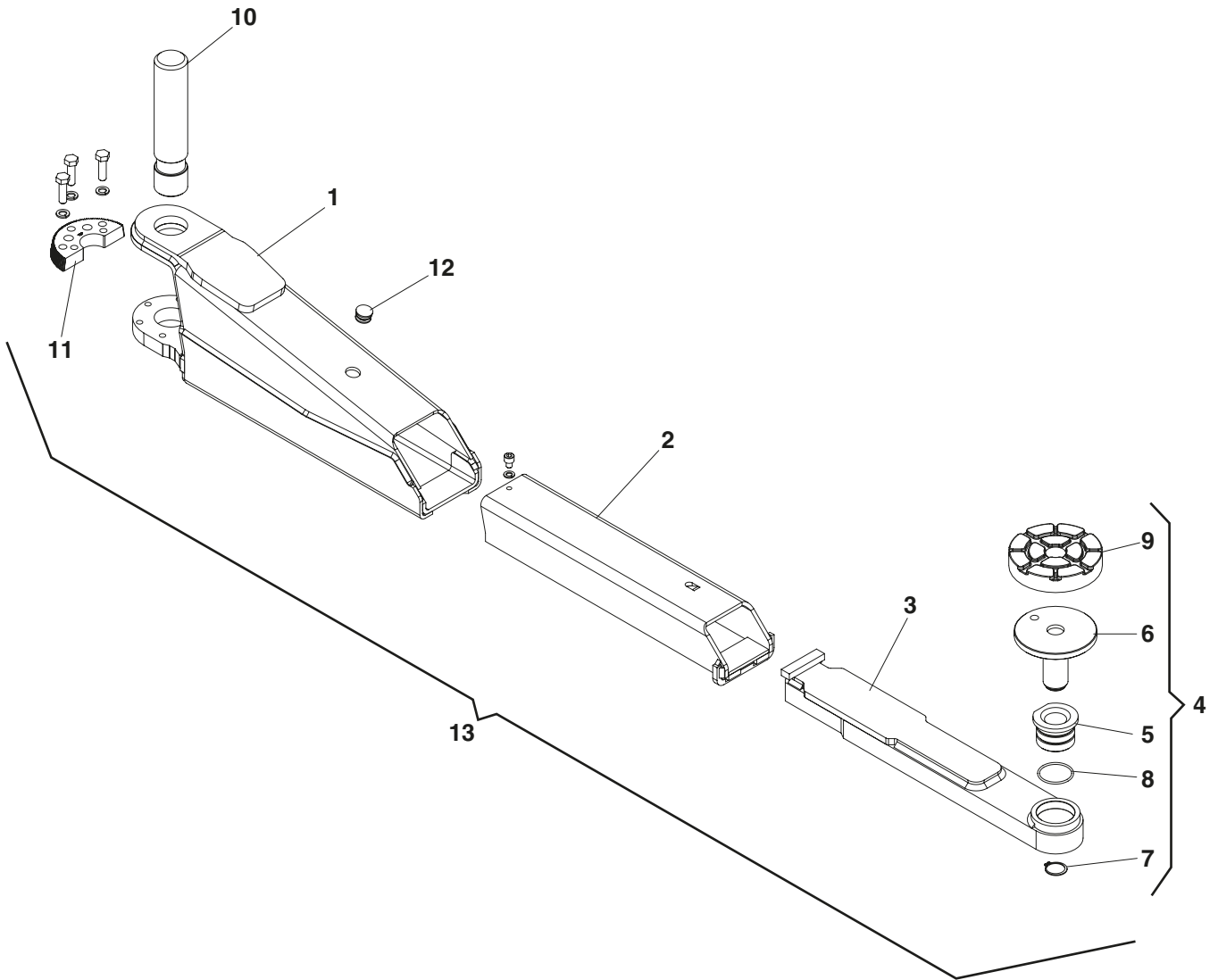

BRACCIO CORTO
SHORT ARM**05B** 0

RIF. REF	CODICE CODE	DESCRIZIONE	DESCRIPTION	APPLICAZIONE APPLICATION
1	047310130	CORPO BRACCIO CORTO	SHORT ARM BODY	TUTTI I MODELLI ALL MODELS
2	047310140	PRIMA PROLUNGA	1st EXTENSION	
3	047311150	SECONDA PROLUNGA	2nd EXTENSION	
4	047390490	MTG TAMPONE	STOPPER	
5	047318150	BOCCOLA FILETTATA M33	THREADED BUSHING	
6	047311320	PIATTELLO	PLATE	
7	243015	SEEGER EST.27	SEEGER EST.27	
8	401051	GUARNIZIONE OR	GASKET OR	
9	047305020	TAMPONE D.125	STOPPER Ø125	
10	N2154	PERNO BRACCIO	ARMS PIN	
11	N2122	RUOTA DENTATA ARRESTO BRACCI	ARM STOP GEAR WHEEL	
12	413166	TAPPO	PLUG	
13	047390060	MTG. BRACCIO CORTO	ARM FIXTURE	

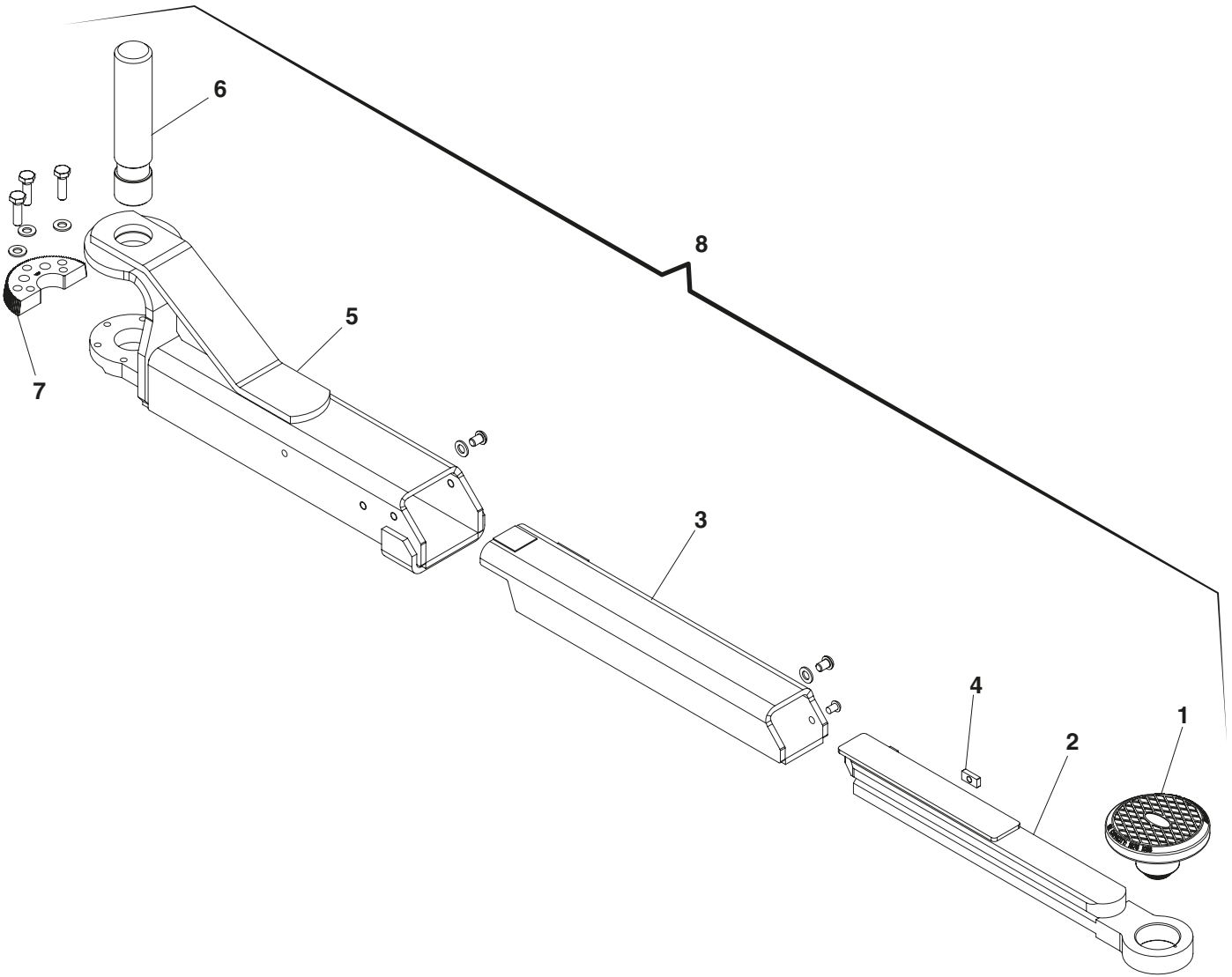



Denominazione tavola – Table definition

N°
tavolaTable
NoIndice di
modificaChange
indexBRACCIO CORTO
SHORT ARM

05C

0

RIF. REF	CODICE CODE	DESCRIZIONE	DESCRIPTION	APPLICAZIONE APPLICATION
1	FJ6202L	MTG TAMPONE	STOPPER	TUTTI I MODELLI ALL MODELS
2	H2220-6G	SECONDA PROLUNGA	2nd EXTENSION	
3	H2292-2G	PRIMA PROLUNGA	1st EXTENSION	
4	H2294-1G	PATTINO	SLIDING SHOE	
5	H2294-3G	CORPO BRACCIO	ARM BODY	

BRACCIO CORTO
SHORT ARM

05D 0

RIF. REF	CODICE CODE	DESCRIZIONE	DESCRIPTION	APPLICAZIONE APPLICATION
1	049615951	CORPO BRACCIO CORTO	SHORT ARM BODY	TUTTI I MODELLI ALL MODELS
2	049615971	SFILO BRACCIO SX	LH ARM EXTENSION	
3	047222380	SFILO	EXTENSION	
4	SPL40-4000	MTG TAMPONE	STOPPER	
5	N2154	PERNO BRACCIO	ARMS PIN	
6	N2122	RUOTA DENTATA ARRESTO BRACCI	ARM STOP GEAR WHEEL	
7	049615590	PIASTRA BRACCIO	ARM PLATE	
8	049615601	SPESSORE BRACCIO	ARM THICKNESS	
9	049615610	PIASTRA BRACCIO	ARM PLATE	
10	049615621	SPESSORE BRACCIO	ARM THICKNESS	
11	047222410	CURSORE A MOLLA	SPRING SLIDER	
12	950001950	MOLLA ARRESTO DENTATO CORTA	STOP SPRING	
13	047222420	LEVA SGANCIO	RELEASE LEVER	
14	950001930	MOLLA RICHIAMO SBLOCCO	RELEASE RETURN SPRING	
15	401121	GUARNIZIONE OR	GASKET OR	
16	903183	IMPUGNATURA	IMPUGNATURA	
17	047222460	INSERTO	INSERT	
18	413324	TAPPO A LAMELLE	PLUG	
19	049615520	PERNO BRACCIO	ARMS PIN	
20	237524	RONDELLA DI SPESS.40X50X0,5	WASHER THICKNESS 40X50X0.5	
21	047222471	RONDELLA SP.0,3MM	WASHER TH.0.3MM	
22	237542	RONDELLA D'APPOGG. D.35X45X0	SUPPORT WASHER D.35X45X0	
23	299098	GHIERA	RING NUT	
24	049615961	SFILO BRACCIO DX	RH ARM EXTENSION	
25	049690020	MTG. BRACCIO CORTO SX	LH SHORT ARM FIXTURE	
26	049690030	MTG. BRACCIO CORTO DX	RH SHORT ARM FIXTURE	

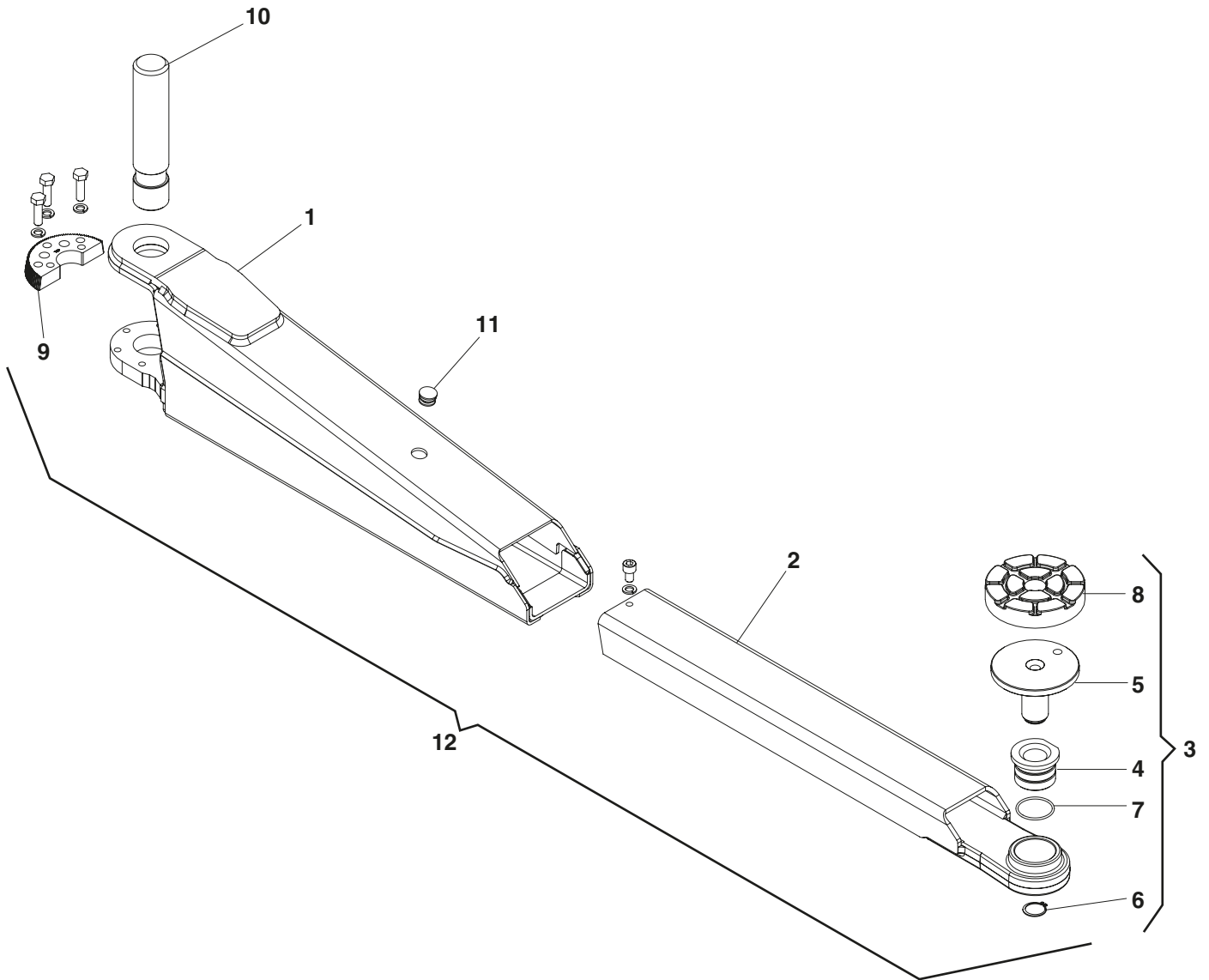

BRACCIO LUNGO
LONG ARM**06A** 0

RIF. REF	CODICE CODE	DESCRIZIONE	DESCRIPTION	APPLICAZIONE APPLICATION
1	047310270	CORPO BRACCIO LUNGO	LONG ARM BODY	TUTTI I MODELLI ALL MODELS
2	047311250	PROLUNGA	EXTENSION	
3	047390410	MTG TAMPONE	STOPPER	
4	047318150	BOCCOLA FILETTATA M33	THREADED BUSHING	
5	048417190	PIATTELLO	PLATE	
6	243015	SEEGER EST.27	SEEGER EST.27	
7	401051	GUARNIZIONE OR	GASKET OR	
8	047305020	TAMPONE D.125	STOPPER Ø125	
9	N2122	RUOTA DENTATA ARRESTO BRACCI	ARM STOP GEAR WHEEL	
10	N2154	PERNO BRACCIO	ARMS PIN	
11	413166	TAPPO	PLUG	
12	047390140	MTG. BRACCIO LUNGO	ARM FIXTURE	

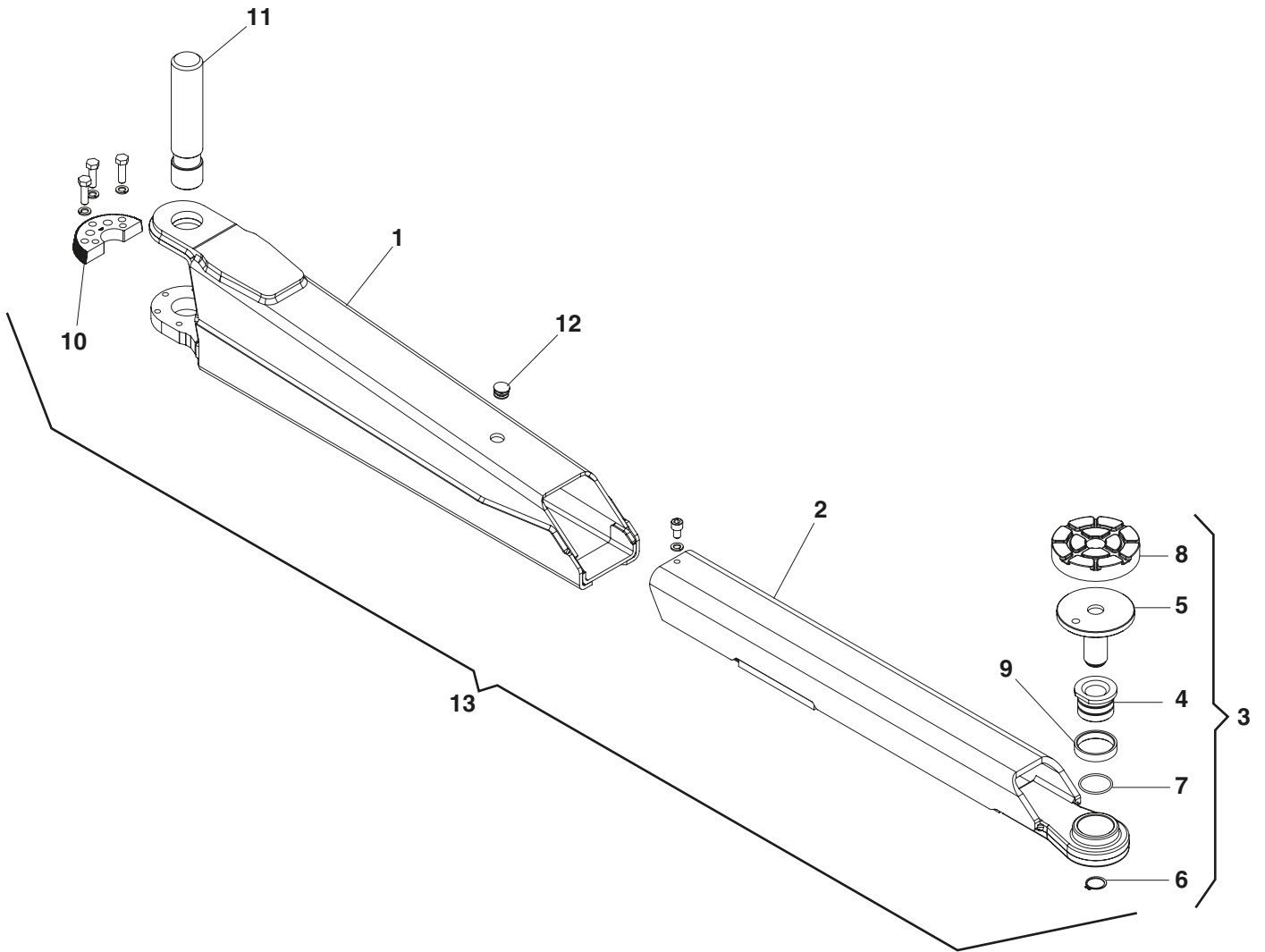

BRACCIO LUNGO
LONG ARM**06B** 0

RIF. REF	CODICE CODE	DESCRIZIONE	DESCRIPTION	APPLICAZIONE APPLICATION
1	047310001	CORPO BRACCIO LUNGO	LONG ARM BODY	TUTTI I MODELLI ALL MODELS
2	047311300	PROLUNGA	EXTENSION	
3	047390490	MTG TAMPONE	STOPPER	
4	047318150	BOCCOLA FILETTATA M33	THREADED BUSHING	
5	047311320	PIATTELLO	PLATE	
6	243015	SEEGER EST.27	SEEGER EST.27	
7	401051	GUARNIZIONE OR	GASKET OR	
8	047305020	TAMPONE D.125	STOPPER Ø125	
9	047311120	DISTANZIALE TAMPONE	STOPPER SPACER	
10	N2122	RUOTA DENTATA ARRESTO BRACCI	ARM STOP GEAR WHEEL	
11	N2154	PERNO BRACCIO	ARMS PIN	
12	413166	TAPPO	PLUG	
13	047390050	MTG. BRACCIO LUNGO	ARM FIXTURE	

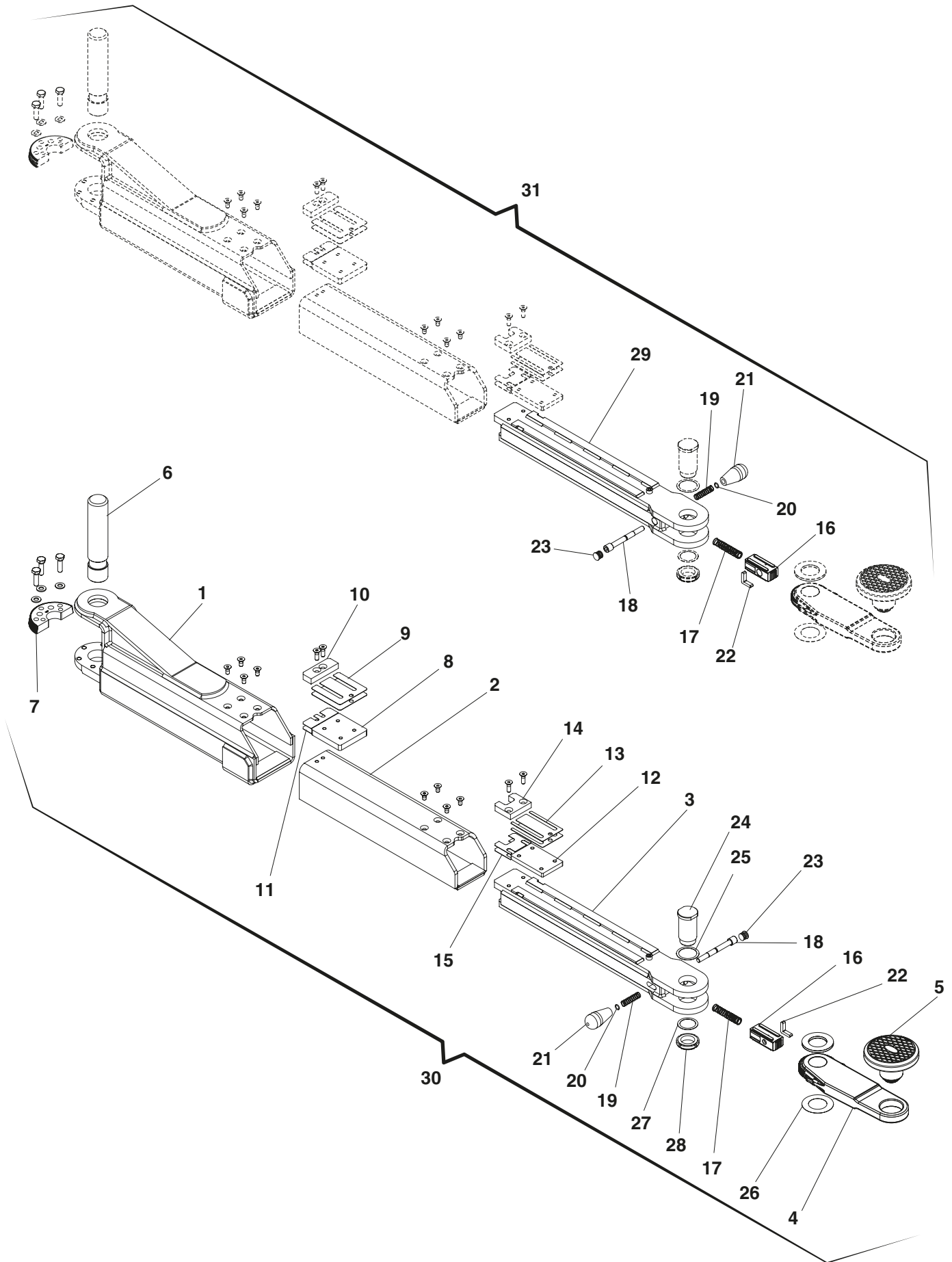

BRACCIO LUNGO
LONG ARM

06C

0

RIF. REF	CODICE CODE	DESCRIZIONE	DESCRIPTION	APPLICAZIONE APPLICATION
1	049615871	CORPO BRACCIO LUNGO	LONG ARM BODY	TUTTI I MODELLI ALL MODELS
2	049615881	SFILO BRACCIO LUNGO	LONG ARM EXTENSION	
3	049615890	SFILO BRACCIO LUNGO SX	LH LONG ARM EXTENSION	
4	047222380	SFILO	EXTENSION	
5	SPL40-4000	MTG TAMPONE	STOPPER	
6	N2154	PERNO BRACCIO	ARMS PIN	
7	N2122	RUOTA DENTATA ARRESTO BRACCI	ARM STOP GEAR WHEEL	
8	049615851	PIASTRA BRACCIO	ARM PLATE	
9	049615841	SPESSORE BRACCIO	ARM THICKNESS	
10	049615831	PIASTRA BRACCIO	ARM PLATE	
11	049615820	SPESSORE BRACCIO	ARM THICKNESS	
12	049615781	PIASTRA BRACCIO	ARM PLATE	
13	049615811	SPESSORE BRACCIO	ARM THICKNESS	
14	049615801	PIASTRA BRACCIO	ARM PLATE	
15	049615790	SPESSORE BRACCIO	ARM THICKNESS	
16	047222410	CURSORE A MOLLA	SPRING SLIDER	
17	950001950	MOLLA ARRESTO DENTATO CORTA	STOP SPRING	
18	047222420	LEVA SGANCIO	RELEASE LEVER	
19	950001930	MOLLA RICHIAMO SBLOCCO	RELEASE RETURN SPRING	
20	401121	GUARNIZIONE OR	GASKET OR	
21	903183	IMPUGNATURA	IMPUGNATURA	
22	047222460	INSERTO	INSERT	
23	413324	TAPPO A LAMELLE	PLUG	
24	049615520	PERNO BRACCIO	ARMS PIN	
25	237524	RONDELLA DI SPESS.40X50X0,5	WASHER THICKNESS 40X50X0.5	
26	047222471	RONDELLA SP.0,3MM	WASHER TH.0.3MM	
27	237542	RONDELLA D'APPOGG. D.35X45X0	SUPPORT WASHER D.35X45X0	
28	299098	GHIERA	RING NUT	
29	049615940	SFILO BRACCIO LUNGO DX	RH LONG ARM EXTENSION	
30	049690000	MTG. BRACCIO LUNGO SX	LH LONG ARM FIXTURE	
31	049690010	MTG. BRACCIO LUNGO DX	RH LONG ARM FIXTURE	

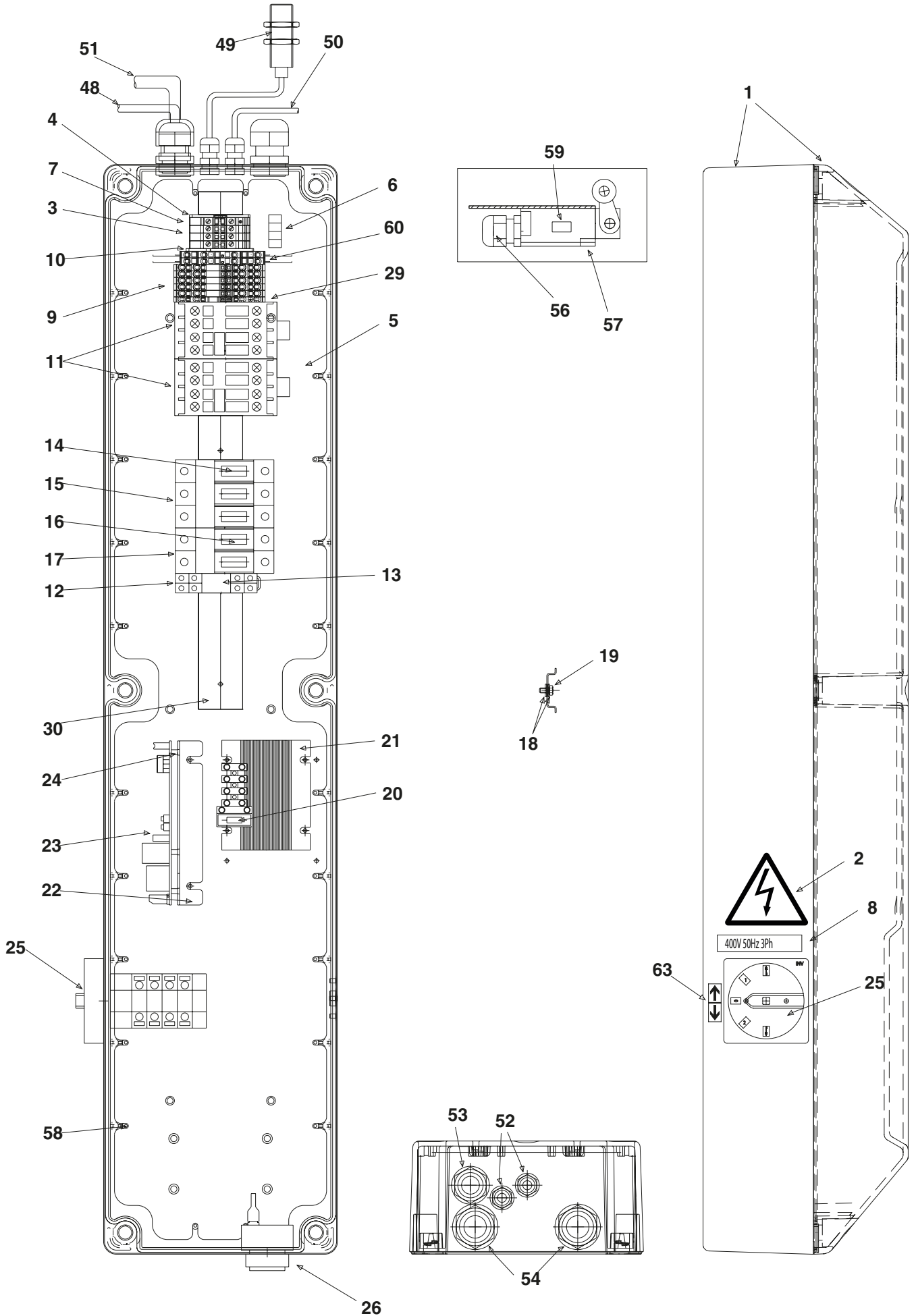

IMPIANTO ELETTRICO
ELECTRIC INSTALLATION

07A 0

RIF. REF	CODICE CODE	DESCRIZIONE	DESCRIPTION	APPLICAZIONE APPLICATION
1	047365250	CASSETTA ELETTRICA E COPERTURA	ELECTRIC BOX SUPER-BASE COVER	TUTTI I MODELLI ALL MODELS
2	99990758	ETICHETTA DI PERICOLO TENSIONE	VOLTAGE DANGER LABEL	
3	510244	MORSETTO A VITE DA 4MM	4MM SCREW CLAMP	
4	510249	PIASTRA FINALE 2,5mm-10mm	END PLATE 2.5mm-10mm	
5	047365050	PIASTRA ELETTRICA	ELECTRIC PLATE	
6	999912900	ETICHETTA DI ALIMENTAZIONE PRINCIPALE	MAIN POWER LABEL	
7	510251	MORSETTO A VITE IN PE 4MM	4MM PE SCREW CLAMP	
8	999912380	ETICHETTA DI TENSIONE 400V 50HZ 3PH	TENSION LABEL 400V 50HZ 3PH	
9	510263	MORSETTO 1.5mm 4 CONNESSIONI	CLAMP 1.5mm 4 CONNECTIONS	
10	510264	PIASTRA TERMINALE PER MORSETTO 1,5 mm 2 PIANI DOPPI ATTACCHI	END PLATE FOR CLAMP 1.5 mm 2 FLOORS DOUBLE CONNECTIONS	
11	522137	MOTORE 1-2 COMANDO CONTATTORE AC3 4KW 400V BF09 01 A024	MOTOR 1-2 COMMAND CONTACTOR AC3 4KW 400V BF09 01 A024	
11	522084	FILTRO RC RC02B05/630R100	R-C FILTER RC02B05/630R100	
12	557018	RELÈ ZOCCOLO 2 CONTATTI	RELAY PLINTH 2 CONTACTS	
13	557021	RELÈ A 2 CONTATTI	2 CONTACTS RELAY	
14	507050	FUSIBILE RITARDATO 10X38, 20A, 500V aM	DELAYED FUSE 10X38, 20A, 500V aM	
15	515025	PORTA FUSIBILE TRIPOLARE 10X38	THREE-POLE FUSE PORT 10X38	
16	507095	FUSIBILE 1A FAST 10X38 500V gl	FUSE 1A FAST 10X38 500V gl	
17	515027	PORTAFUSIBILE DOPPIO 10X38	DOUBLE FUSE HOLDER 10X38	
18	239018	RONDELLA DENSA DIAMETRO 4,3 mm	NOTCHED WASHER DIAMETER 4.3mm	
19	220005	VITE A TESTA CILINDRICA AUTOFILETTANTE	CYLINDRICAL HEAD SCREW SELF TAPPING	
20	507069	FUSIBILE 4A 5x20F 250V PROTEZIONE LINEA 24VAC	FUSE 4A 5x20F 250V LINE PROTECTION 24VAC	
21	528031	TRASFORMATORE 100VA CO-230-400/0-24 CON PORTAFUSIBILE SU LINEA 24V	100VA TRANSFORMER CO-230-400/0-24 WITH FUSE HOLDER ON 24V LINE	
22	047365090	SUPPORTO PER LA SCHEDA ELETTRONICA	SUPPORT FOR THE ELECTRONIC BOARD	
23	20922	SCHEDA ELETTRONICA	ELECTRONIC BOARD	
24	569012	DISTANZIALE PER SCHEDA ELETTRONICA LCBS-3-01	SPACER FOR ELECTRONIC BOARD LCBS-3-01	
25	518305	MANOPOLA ROSSA CON BASE GIALLA 67X67 010/1429-1	RED ELECTRIC KNOB WITH YELLOW BASE 67X67 010/1429-1	
25	518306	INVERTER DI FASE 20A 3Ph 1 AUX	PHASE INVERTER 20A 3Ph 1 AUX	
26	569046	SEGNALE ACUSTICO PFD-35N29EPQ	BUZZER PFD-35N29EPQ	
29	510277	MORSETTO CON 4 ATTACCHI 1,5mm	CLAMP WITH 4 CONNECTIONS 1.5mm	
30	048565540	GUIDA DIN	DIN GUIDE	
48	047365110	CAVO COLONNA PRINCIPALE M1	MASTER COLUMN M1 CABLE	
49	047365130	COLONNA PRINCIPALE DI PROSSIMITÀ FCP1 CON CAVO XS618B1PAL2	MASTER COLUMN PROXIMITY FCP1 WITH CABLE XS618B1PAL2	
50	047365141	MICRO INTERRUPTORE DISCESA COLONNA PRINCIPALE FC2	MASTER COLUMN LIFT DOWN MICRO SWITCH FC2	
51	047365151	CAVO DA SCATOLA DI DERIVAZIONE A COLONNA PRINCIPALE	CABLE FROM JUNCTION BOX TO MASTER COLUMN	
52	599428	PRESSACAVO M12X1.5	CABLE GLAND M12X1.5	
52	599431	ANELLO M12X1.5 1143M12	RING M12X1.5 1143M12	
53	599429	PRESSACAVO M20X1.5	CABLE GLAND M20X1.5	
53	599432	ANELLO M20X1.5 1143M20	RING M20X1.5 1143M20	
54	599430	PRESSACAVO M25X1.5	CABLE GLAND M25X1.5	
54	599433	ANELLO M25X1.5 1143M25	RING M25X1.5 1143M25	
56	599252	PRESSACAVO PG11 1900.11	CABLE GLAND PG11 1900.11	
57	527083	MICROINTERRUPTORE FR552A	MICRO SWITCH FR552A	
58	220052	VITE A TESTA CILINDRICA AUTOFILETTANTE 2.9mm X 9.4mm	CYLINDRICAL HEAD SCREW SELF TAPPING 2.9mm X 9.4mm	
59	999909170	ETICHETTA ADESIVA COLONNA PRINCIPALE FC2	ADHESIVE LABEL FC2 MASTER COLUMN	
60	510262	MORSETTO A DOPPIO COLLEGAMENTO A DUE PAVIMENTI 1.5mm	TWO FLOOR DOUBLE CONNECTIONS CLAMP 1.5mm	
63	999912710	ETICHETTA FRECCHE SU - GIÙ	UP AND DOWN ARROWS LABEL	

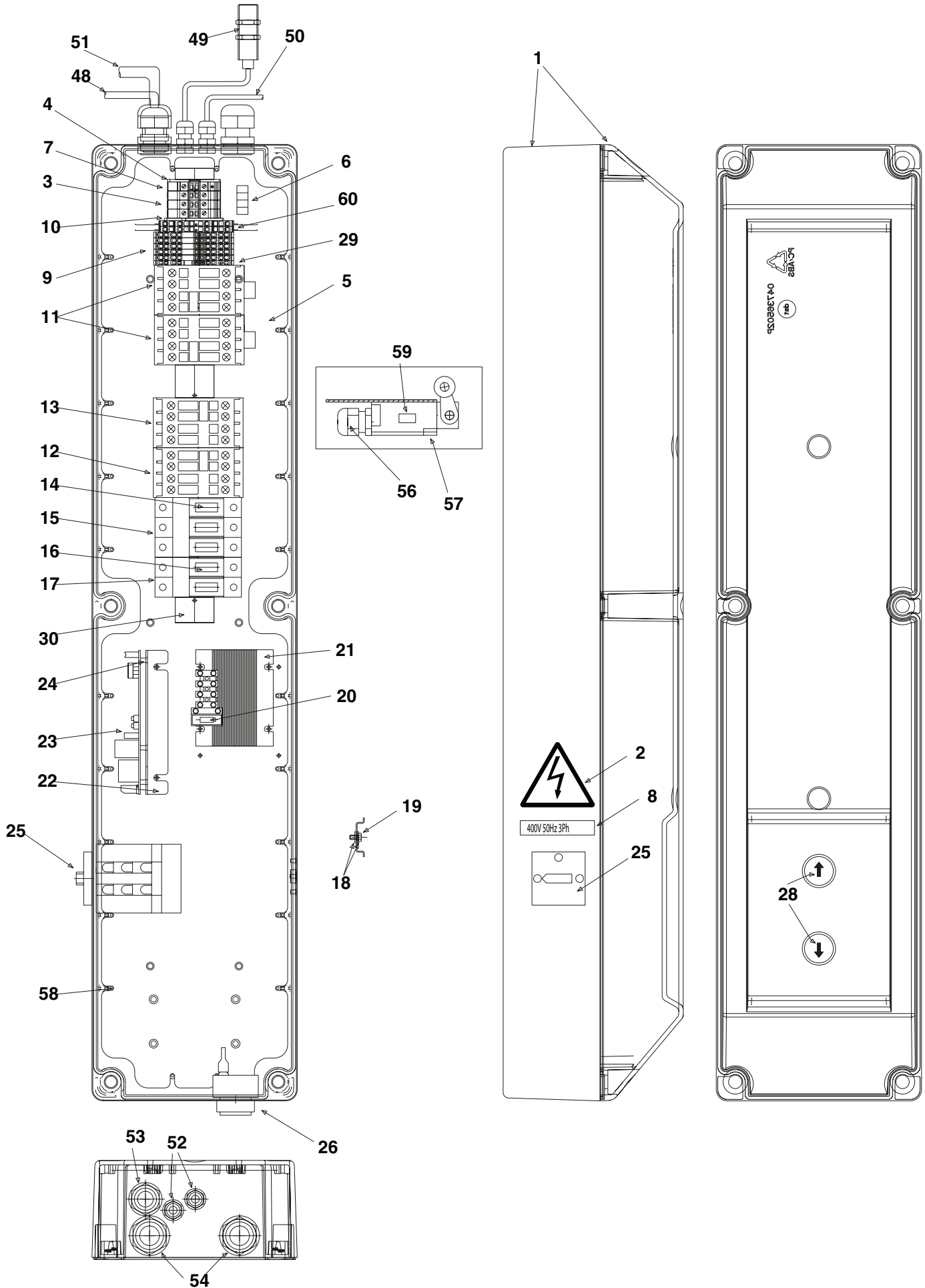

IMPIANTO ELETTRICO
ELECTRIC INSTALLATION

07B 0

RIF. REF	CODICE CODE	DESCRIZIONE	DESCRIPTION	APPLICAZIONE APPLICATION
1	047365210	CASSETTA ELETTRICA E COPERTURA	ELECTRIC BOX RAVAGLIOLI COVER	TUTTI I MODELLI ALL MODELS
2	99990758	ETICHETTA DI PERICOLO TENSIONE	VOLTAGE DANGER LABEL	
3	510245	MORSETTO A VITE 6mm 3044131	SCREW CLAMP 6mm 3044131	
4	510249	PIASTRA TERMINALE 2,5mm-10mm 3047028	END PLATE 2.5mm-10mm 3047028	
5	047365050	PIASTRA ELETTRICA	ELECTRIC PLATE	
6	999912900	ETICHETTA DI ALIMENTAZIONE PRINCIPALE	MAIN POWER LABEL	
7	510252	MORSETTO PE CON VITE 6mm	PE CLAMP WITH SCREW 6mm	
8	999912380	ETICHETTA DI TENSIONE 400V 50HZ 3PH	TENSION LABEL 400V 50HZ 3PH	
9	510263	MORSETTO 1.5mm 4 CONNESSIONI	CLAMP 1.5mm 4 CONNECTIONS	
10	510264	PIASTRA TERMINALE PER MORSETTO 1,5 mm 2 PIANI DOPPI ATTACCHI	END PLATE FOR CLAMP 1.5 mm 2 FLOORS DOUBLE CONNECTIONS	
11	522143	MOTORE 1-2 COMANDO CONTATTORE AC3 7.5KW 400V BF18 01 A024	MOTOR 1-2 COMMAND CONTACTOR AC3 7.5KW 400V BF18 01 A024	
11	522084	FILTRO RC RC02B05/630R100	R-C FILTER RC02B05/630R100	
12	522142	CONTATTORE COMANDO DISCESA AC3 12.5KW 400V BF25 01 A024	CONTACTOR LIFT DOWN COMMAND AC3 12.5KW 400V BF25 01 A024	
12	522146	CONTATTI AUSILIARI 11 G418 10	AUXILIARY CONTACTS 11 G418 10	
13	522142	COMANDO SOLLEVAMENTO CONTATTORE AC3 12.5KW 400V BF25 01 A024	CONTACTOR LIFT UP COMMAND AC3 12.5KW 400V BF25 01 A024	
13	522145	AUS. CONTATTI BFX10 20	AUX. CONTACTS BFX10 20	
13	522146	AUS. CONTATTI 11 G418 10	AUX. CONTACTS 11 G418 10	
14	507107	FUSIBILE RITARDATO 10X38, 32A, 400V aM	DELAYED FUSE 10X38, 32A, 400V aM	
15	515025	PORTA FUSIBILE TRIPOLARE 10X38	THREE-POLE FUSE PORT 10X38	
16	507095	FUSIBILE 1A FAST 10X38 500V gl	FUSE 1A FAST 10X38 500V gl	
17	515027	PORTAFUSIBILE DOPPIO 10X38	DOUBLE FUSE HOLDER 10X38	
18	239018	RONDELLA DENSA DIAMETRO 4,3 mm	NOTCHED WASHER DIAMETER 4.3mm	
19	220005	VITE A TESTA CILINDRICA AUTOFILETTANTE 3.5mm x 9.5mm 6954AB DIN7981 6X3/8	CYLINDRICAL HEAD SCREW SELF TAPPING 3.5mm x 9.5mm 6954AB DIN7981 6X3/8	
20	507069	FUSIBILE 4A 5x20F 250V PROTEZIONE LINEA 24VAC	FUSE 4A 5x20F 250V LINE PROTECTION 24VAC	
21	528031	TRASFORMATORE 100VA 0-230-400/0-24 CON PORTAFUSIBILE SU LINEA 24V	100VA TRANSFORMER 0-230-400/0-24 WITH FUSE HOLDER ON 24V LINE	
22	047365090	SUPPORTO PER LA SCHEDA ELETTRONICA KGR	SUPPORT FOR THE ELECTRONIC BOARD KGR	
23	20922	SCHEDA ELETTRONICA KGR	ELECTRONIC BOARD KGR	
24	569012	DISTANZIALE PER SCHEDA ELETTRONICA LCBS-3-01	SPACER FOR ELECTRONIC BOARD LCBS-3-01	
25	518302	INTERRUTTORE PRINCIPALE 4 POLI+AUX 32A C0323027S+004/3027	MAIN SWITCH 4 POLES+AUX 32A C0323027S+004/3027	
26	569046	SEGNALE ACUSTICO PFD-35N29EPQ	BUZZER PFD-35N29EPQ	
28	517330	PULSANTE SINGOLO NERO CON FRECCIA BIANCA E ANELLO NERO E2 1PU2R121L7	SINGLE BLACK BUTTON WITH WHITE ARROW AND BLACK RING E2 1PU2R121L7	
28	517329	SUPPORTO 3 CONTATTI IN PLASTICA E2 1BAC11	3 CONTACTS SUPPORT IN PLASTIC E2 1BAC11	
28	517352	BLOCCO CONTATTI NA CON VITE E2 CP10G2V1	CONTACT BLOCK, NO WITH SCREW E2 CP10G2V1	
28	517353	BLOCCO CONTATTI NC CON VITE E2 CP01G2V1	CONTACT BLOCK NC WITH SCREW E2 CP01G2V1	
29	510277	MORSETTO PE CON 4 CONNESSIONI 1.5mm	PE CLAMP WITH 4 CONNECTIONS 1.5mm	
30	048565540	GUIDA DIN	DIN GUIDE	
48	047365110	CAVO COLONNA PRINCIPALE M1	MASTER COLUMN M1 CABLE	
49	047365130	COLONNA PRINCIPALE DI PROSSIMITÀ FCP1 CON CAVO XS618B1PAL2	MASTER COLUMN PROXIMITY FCP1 WITH CABLE XS618B1PAL2	
50	047365141	MICRO INTERRUTTORE DISCESA COLONNA PRINCIPALE FC2	MASTER COLUMN LIFT DOWN MICRO SWITCH FC2	
51	047365151	CAVO DA SCATOLA DI DERIVAZIONE A COLONNA PRINCIPALE	CABLE FROM JUNCTION BOX TO MASTER COLUMN	
52	599428	PRESSACAVO M12X1.5	CABLE GLAND M12X1.5	
52	599431	ANELLO M12X1.5 1143M12	RING M12X1.5 1143M12	
53	599429	PRESSACAVO M20X1.5	CABLE GLAND M20X1.5	
53	599432	ANELLO M20X1.5 1143M20	RING M20X1.5 1143M20	
54	599430	PRESSACAVO M25X1.5	CABLE GLAND M25X1.5	
54	599433	ANELLO M25X1.5 1143M25	RING M25X1.5 1143M25	
56	599252	PRESSACAVO PG11	CABLE GLAND PG11	
57	527083	MICROINTERRUTTORE FR552A	MICRO SWITCH FR552A	
58	220052	VITE A TESTA CILINDRICA AUTOFILETTANTE 2.9mm X 9.4mm	CYLINDRICAL HEAD SCREW SELF TAPPING 2.9mm X 9.4mm	
59	999909170	ETICHETTA ADESIVA COLONNA PRINCIPALE FC2	ADHESIVE LABEL FC2 MASTER COLUMN	
60	510262	MORSETTO A DOPPIO COLLEGAMENTO A DUE PAVIMENTI 1.5mm	TWO FLOOR DOUBLE CONNECTIONS CLAMP 1.5mm	

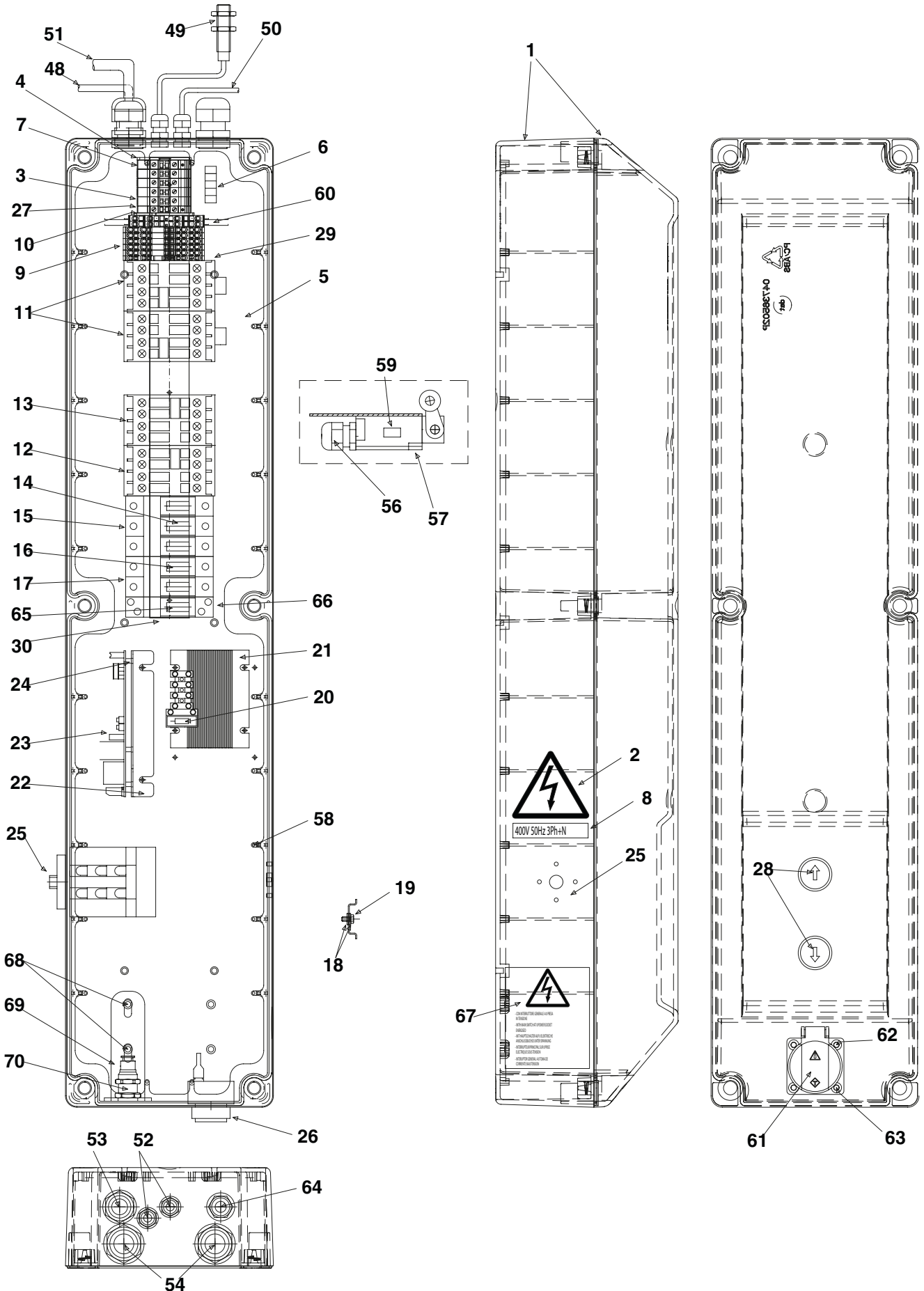

IMPIANTO ELETTRICO
ELECTRIC INSTALLATION07C
0

RIF. REF	CODICE CODE	DESCRIZIONE	DESCRIPTION	APPLICAZIONE APPLICATION
1	047365220	CASSETTA ELETTRICA ENERGY	ELECTRIC BOX ENERGY KIT	TUTTI I MODELLI ALL MODELS
2	99990758	ETICHETTA DI PERICOLO TENSIONE	VOLTAGE DANGER LABEL	
3	510245	MORSETTO A VITE 6mm	SCREW CLAMP 6mm	
4	510249	PIASTRA FINALE 2,5mm-10mm	END PLATE 2.5mm-10mm	
5	047365050	PIASTRA ELETTRICA	ELECTRIC PLATE	
6	999913470	ETICHETTA DI ALIMENTAZIONE PRINCIPALE	MAIN POWER LABEL	
7	510252	MORSETTO PE CON VITE 6mm	PE CLAMP WITH SCREW 6mm	
8	999913010	ETICHETTA DI TENSIONE 400V 50HZ 3PH+N	TENSION LABEL 400V 50HZ 3PH+N	
9	510263	MORSETTO 1.5mm 4 CONNESSIONI	CLAMP 1.5mm 4 CONNECTIONS	
10	510264	PIASTRA TERMINALE PER MORSETTO 1,5 mm 2 PIANI DOPPI ATTACCHI	END PLATE FOR CLAMP 1.5 mm 2 FLOORS DOUBLE CONNECTIONS	
11	522143	MOTORE 1-2 COMM. CONTINUA AC3 7.5KW 400V BF18 01 A024	MOTOR 1-2 COMM. CONT. AC3 7.5KW 400V BF18 01 A024	
11	522084	FILTRO RC RC02B05/630R100	R-C FILTER RC02B05/630R100	
12	522142	CONTATTORE COMANDO DISCESA AC3 12.5KW 400V BF25 01 A024	CONT. LIFT DOWN COMM AC3 12.5KW 400V BF25 01 A024	
12	522146	CONTATTI AUSILIARI 11 G418 10	AUXILIARY CONTACTS 11 G418 10	
13	522142	CONT.LIFT UP COMM. AC3 12.5KW 400V BF25 01 A024	CONT.LIFT UP COMM. AC3 12.5KW 400V BF25 01 A024	
13	522145	AUS. CONTATTI BFX10 20	AUX. CONTACTS BFX10 20	
13	522146	AUS. CONTATTI 11 G418 10	AUX. CONTACTS 11 G418 10	
14	507107	FUSIBILE RITARDATO 10X38, 32A, 400V aM	DELAYED FUSE 10X38, 32A, 400V aM	
15	515025	PORTA FUSIBILE TRIPOLARE 10X38	THREE-POLE FUSE PORT 10X38	
16	507095	FUSIBILE 1A FAST 10X38 500V gl	FUSE 1A FAST 10X38 500V gl	
17	515027	PORTAFUSIBILE DOPPIO 10X38	DOUBLE FUSE HOLDER 10X38	
18	239018	RONDELLA DENSA DIAMETRO 4,3 mm	NOTCHED WASHER DIAMETER 4.3mm	
19	220005	VITE A TESTA CILINDRICA AUTOFILETTANTE 3,5 mm x 9,5 mm 6954AB DIN7981	CYLINDRICAL HEAD SCREW SELF TAPPING 3.5mm x 9.5mm 6954AB DIN7981	
20	507069	FUSIBILE 4A 5x20F 250V PROTEZIONE LINEA 24VAC 100VA TRAS. 0-230-400/0-24 CON PORTAFUSIBILE SU LINEA 24V	FUSE 4A 5x20F 250V LINE PROTECTION 24VAC 100VA TRANS. 0-230-400/0-24 WITH FUSE HOLDER ON 24V LINE	
21	528031			
22	047365090	SUPPORTO PER LA SCHEDA ELETTRONICA KGR	SUPPORT FOR THE ELECTRONIC BOARD KGR	
23	20922	SCHEDA ELETTRONICA KGR	ELECTRONIC BOARD KGR	
24	569012	DISTANZIALE PER SCHEDA ELETTRONICA LCBS-3-01	SPACER FOR ELECTRONIC BOARD LCBS-3-01	
25	518302	INTERRUTTORE PRINCIPALE 4 POLI+AUX 32A	MAIN SWITCH 4 POLES+AUX 32A	
26	569046	SEGNALE ACUSTICO PFD-35N29EPQ	BUZZER PFD-35N29EPQ	
27	510251	MORSETTO PE CON VITE 4mm 3044128	PE CLAMP WITH SCREW 4mm 3044128	
28	517330	PULSANTE SINGOLO NERO CON FRECCIA BIANCA	SINGLE BLACK BUTTON WITH WHITE ARROW	
28	517329	3 CONTATTI SUPPORTO IN PLASTICA E2	3 CONTACTS SUPPORT IN PLASTIC E2	
28	517352	BLOCCO CONTATTI, NO CON VITE E2	CONTACT BLOCK, NO WITH SCREW E2	
28	517353	BLOCCO CONTATTI NC CON VITE E2	CONTACT BLOCK NC WITH SCREW E2	
29	510277	CLAM PE CON 4 ATTACCHI 1.5mm	PE CLAM WITH 4 CONNECTIONS 1.5mm	
30	048565540	GUIDA DIN	DIN GUIDE	
48	047365110	CAVO COLONNA PRINCIPALE M1	MASTER COLUMN M1 CABLE	
49	047365130	COLONNA PRINCIP. DI PROSSIMITA' FCP1 CON CABL	MASTER COLUMN PROXIMITY FCP1 WITH CABL	
50	047365141	PRINCIP. COL. MICRO INTERR. DISCESA FC2	MASTER COL. LIFT DOWN MICRO SWITCH FC2	
51	047365151	CAVO DA SCATOLA DI DERIVAZ. A COL. PRINCIPALE	CABLE FROM JUNCTION BOX TO MASTER COL.	
52	599428	PRESSACAVO M12X1.5	CABLE GLAND M12X1.5	
52	599431	ANELLO M12X1.5 1143M12	RING M12X1.5 1143M12	
53	599429	PRESSACAVO M20X1.5	CABLE GLAND M20X1.5	
53	599432	ANELLO M20X1.5	RING M20X1.5	
54	599430	PRESSACAVO M25X1.5	CABLE GLAND M25X1.5	
54	599433	ANELLO M25X1.5 1143M25	RING M25X1.5 1143M25	
56	599252	PRESSACAVO PG1	CABLE GLAND PG1	
57	527083	MICROINTERRUTTORE FR552A	MICRO SWITCH FR552A	
58	220052	VITE A TESTA CILINDRICA AUTOFILETTANTE 2.9mm X 9.4mm	CYLINDRICAL HEAD SCREW SELF TAPPING 2.9mm X 9.4mm	
59	999909180	ETICHETTA ADESIVA FC3 MSTER COLONNA	ADHESIVE LABEL FC3 MASTER COLUMN	
60	510262	DUE PIANI DOPPIO CONN. MORSETTO 1,5 mm	TWO FLOOR DOUBLE CONN. CLAMP 1.5mm	
61	058765800	PRESA 230V SCHUKO 16A	SOCKET 230V SCHUKO 16A	
62	209160	VITE TPSEI M4X12 5933 ZN	SCREW TPSEI M4X12 5933 ZN	
63	228036	MATRICE AUTOBLOCCANTE BASSA M4	SELF LOCKING DIE LOW M4	
64	599472	PRESSACAVO M16X1.5N 1900.M16	CABLE GLAND M16X1.5N 1900.M16	
64	599473	ANELLO M16X1.5 1143M16	RING M16X1.5 1143M16	
65	507009	FUSIBILE 16A VELOCE 10X38 500V gl	FUSE 16A FAST 10X38 500V gl	
66	515038	PORTAFUSIBILE 1P+N 5450120	FUSE HOLDER 1P+N 5450120	
67	999921350	PRESA ETICHETTA SEMPRE IN TENSIONE 220V	LABEL SOCKET ALWAYS UNDER TENSION 220V	
68	220068	VITE AUTOFILETTANTE 6,3X13 6950AB ZN	SELF TAPPING SCREW 6,3X13 6950AB ZN	
69	047318700	PIASTRA DI FISS. PER LA LAMIERA DI LAMIERA	FIXING PLATE FOR THE SHEET METAL LINK	
70	325093	MAGLIA LAMIERA D.8X1/4 814080	SHEET METAL LINK D.8X1/4 814080	

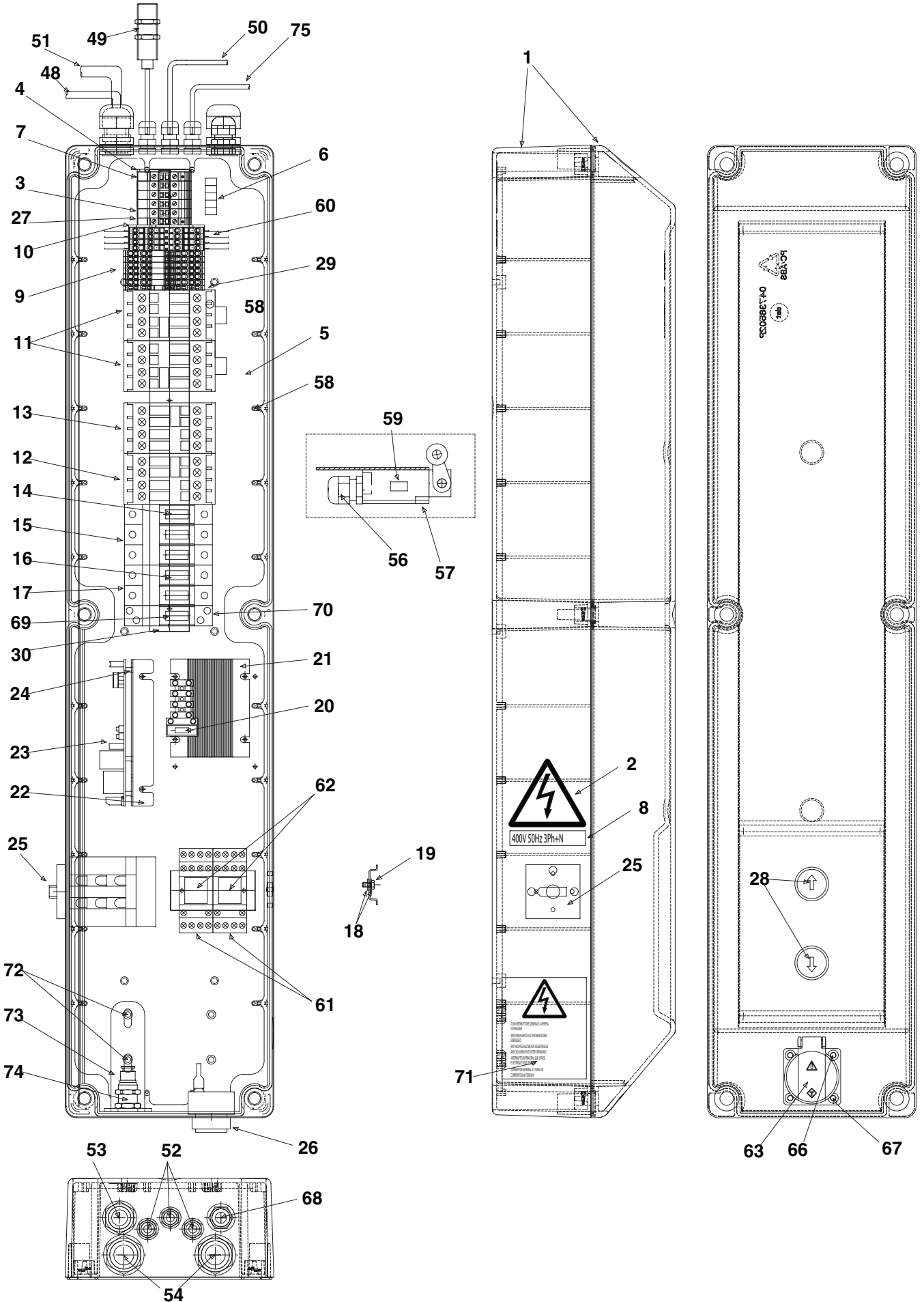

IMPIANTO ELETTRICO
ELECTRIC INSTALLATION

07D

0

RIF. REF	CODICE CODE	DESCRIZIONE	DESCRIPTION	APPLICAZIONE APPLICATION
1	047365380	CASSETTA ELETTRICA	EL.BOX RAV DOUBLE COM. HOLESS	TUTTI I MODELLI ALL MODELS
2	99990758	ETICHETTA DI PERICOLO TENSIONE	VOLTAGE DANGER LABLE	
3	510245	MORSETTO A VITE 6mm	SCREW CLAMP 6mm	
4	510249	PIASTRA FINALE 2,5mm-10mm	END PLATE 2.5mm-10mm	
5	047365050	PIASTRA ELETTRICA	ELECTRIC PLATE	
6	999913470	ETICHETTA DI ALIMENTAZIONE PRINCIPALE	MAIN POWER LABEL	
7	510252	MORSETTO PE CON VITE 6mm	PE CLAMP WITH SCREW 6mm	
8	999913010	ETICHETTA DI TENSIONE 400V 50HZ 3PH+N	TENSION LABLE 400V 50HZ 3PH+N	
9	510263	MORSETTO 1.5mm 4 CONNESSIONI	CLAMP 1.5mm 4 CONNECTIONS	
10	510264	PIASTRA TERMINALE PER MORSETTO 1,5 mm 2 PIANI DOPPI ATTACCHI	END PLATE FOR CLAMP 1.5 mm 2 FLOORS DOUBLE CONNECTIONS	
11	522143	MOTORE 1-2 COMANDO CONTATTORE AC3 7.5KW 400V BF18 01 A024	MOTOR 1-2 COMMAND CONTACTOR AC3 7.5KW 400V BF18 01 A024	
11	522084	FILTRO RC RC02B05/630R100	R-C FILTER RC02B05/630R100	
12	522142	CONTATTORE COMANDO DISCESA AC3 12.5KW 400V BF25 01 A024	CONTACTOR LIFT DOWN COMMAND AC3 12.5KW 400V BF25 01 A024	
12	522146	CONTATTI AUSILIARI 11 G418 10	AUXILIARY CONTACTS 11 G418 10	
13	522142	COMANDO SOLLEVAMENTO CONTATTORE AC3 12.5KW 400V BF25 01 A024	CONTACTOR LIFT UP COMMAND AC3 12.5KW 400V BF25 01 A024	
13	522145	AUS. CONTATTI BFX10 20	AUX. CONTACTS BFX10 20	
13	522146	AUS. CONTATTI 11 G418 10	AUX. CONTACTS 11 G418 10	
14	507107	FUSIBILE RITARDATO 10X38, 32A, 400V aM	DELAYED FUSE 10X38, 32A, 400V aM	
15	515025	PORTA FUSIBILE TRIPOLARE 10X38	THREE-POLE FUSE PORT 10X38	
16	507095	FUSIBILE 1A FAST 10X38 500V gl	FUSE 1A FAST 10X38 500V gl	
17	515027	PORTAFUSIBILE DOPPIO 10X38 5450103S	DOUBLE FUSE HOLDER 10X38 5450103S	
18	239018	RONDELLA TAGLIATA DIAMETRO 4,3mm	NOTCHED WASHER DIAMETRO 4.3mm	
19	220005	VITE A TESTA CILINDRICA AUTOFILETTANTE 3,5 mm x 9,5 mm 6954AB DIN7981	CYLINDRICAL HEAD SCREW SELF TAPPING 3.5mm x 9.5mm 6954AB DIN7981	
20	507069	FUSIBILE 4A 5x20F 250V PROTEZIONE LINEA 24VAC	FUSE 4A 5x20F 250V LINE PROTECTION 24VAC	
21	528031	TRASFORMATORE 100VA 0-230-400/0-24 CON PORTAFUSIBILE SU LINEA 24V	100VA TRANSFORMER 0-230-400/0-24 WITH FUSE HOLDER ON 24V LINE	
22	047365090	SUPPORTO PER LA SCHEDA ELETTRONICA KGR	SUPPORT FOR THE ELECTRONIC BOARD KGR	
23	20922	SCHEDA ELETTRONICA KGR	ELECTRONIC BOARD KGR	
24	569012	DISTANZIALE PER SCHEDA ELETTRONICA	SPACER FOR ELECTRONIC BOARD	
25	518302	INTERRUTTORE PRINCIPALE 4 POLI+AUX 32A C0323027S+004/3027	MAIN SWITCH 4 POLES+AUX 32A C0323027S+004/3027	
26	569046	SEGNALE ACUSTICO PFD-35N29EPQ	BUZZER PFD-35N29EPQ	
27	510251	MORSETTO PE CON VITE 4mm 3044128	PE CLAMP WITH SCREW 4mm 3044128	
28	517330	PULSANTE SINGOLO NERO CON FRECCIA BIANCA E ANELLO NERO	SINGLE BLACK BUTTON WITH WHITE ARROW AND BLACK RING	
28	517329	3 CONTATTI SUPPORTO IN PLASTICA E2	3 CONTACTS SUPPORT IN PLASTIC E2	
28	517352	BLOCCO CONTATTI, NO CON VITE E2	CONTACT BLOCK, NO WITH SCREW E2	
28	517353	BLOCCO CONTATTI NC CON VITE E2	CONTACT BLOCK NC WITH SCREW E2	
29	510277	CLAM PE CON 4 ATTACCHI 1.5mm	PE CLAM WITH 4 CONNECTIONS 1.5mm	
30	048565540	GUIDA DIN	DIN GUIDE	
48	047365110	CAVO COLONNA PRINCIPALE M1	MASTER COLUMN M1 CABLE	
49	047365130	COLONNA PRINCIP. DI PROSSIMITA' FCP1 CON CAVO	MASTER COLUMN PROXIMITY FCP1 WITH CABLE	
50	047365141	MICRO INTERRUTTORE DISCESA COLONNA PRINCIPALE FC2	MASTER COLUMN LIFT DOWN MICRO SWTICH FC2	
51	047365320	CAVO DA ARMADIO PRINCIPALE A ARMADIO SECONDARIO VERSIONE INTERFACCIA UTENTE	CABLE FROM MASTER CABINET TO SLAVE CABINET USER INTERFACE VERSION	
52	599611	PRESSACAVO M12X1.5	CABLE GLAND M12X1.5	
52	599431	ANELLO M12X1.5 1143M12	RING M12X1.5 1143M12	
53	599429	PRESSACAVO M20X1.5	CABLE GLAND M20X1.5	
53	599432	ANELLO M20X1.5 1143M20	RING M20X1.5 1143M20	
54	599430	PRESSACAVO M25X1.5	CABLE GLAND M25X1.5	
54	599433	ANELLO M25X1.5 1143M25	RING M25X1.5 1143M25	
56	599252	PRESSACAVO PG11	CABLE GLAND PG11	
57	527083	MICROINTERRUTTORE FR552A	MICRO SWITCH FR552A	
58	220052	VITE A TESTA CILINDRICA AUTOFILETTANTE 2.9mm X 9.4mm	CYLINDRICAL HEAD SCREW SELF TAPPING 2.9mm X 9.4mm	
59	999909170	ETICHETTA ADESIVA FC2 MSTER COLONNA	ADHESIVE LABLE FC2 MSTER COLUMN	
60	510262	MORSETTO A DOPPIO COLLEGAMENTO A DUE PAVIMENTI 1.5mm	TWO FLOOR DOUBLE CONNECTIONS CLAMP 1.5mm	
61	557028	RELÉ ZOCCOLO 4 CONTATTI 94.74SMA	RELAY PLINTH 4 CONTACTS 94.74SMA	
62	557027	4 CONTATTI RELE 55.34.8.024.0040	4 CONTACTS RELAY 55.34.8.024.0040	
63	058765800	PRESA 230V SCHUKO 16A	SOCKET 230V SCHUKO 16A	
66	209160	VITE TPSEI M4X12 5933 ZN	SCREW TPSEI M4X12 5933 ZN	
67	228036	MATRICE AUTOBLOCCANTE BASSA M4	SELF LOCKING DIE LOW M4	
68	599612	PRESSACAVO M16X1.5	CABLE GLAND M16X1.5	
68	599473	ANELLO M16X1.5 1143M16	RING M16X1.5 1143M16	
69	507009	FUSIBILE 16A VELOCE 10X38 500V gl	FUSE 16A FAST 10X38 500V gl	
70	515038	PORTAFUSIBILE 1P+N 5450120	FUSE HOLDER 1P+N 5450120	
71	999921350	PRESA ETICHETTA SEMPRE IN TENSIONE 220V	LABEL SOCKET ALWAYS UNDER TENSION 220V	
72	220123	VITE AUTOFILETTANTE 5,5X13 6954AB	SELF TAPPING SCREW 5,5X13 6954AB	
73	047318700	PIASTRA DI FISSAGGIO PER LA LAMIERA	FIXING PLATE FOR THE SHEET METAL LINK	
74	325093	MAGLIA LAMIERA D.8X1/4 814080	SHEET METAL LINK D.8X1/4 814080	
75	047365330	PULSANTI SEGNALI CAVO	BUTTONS SIGNALS CABLE	

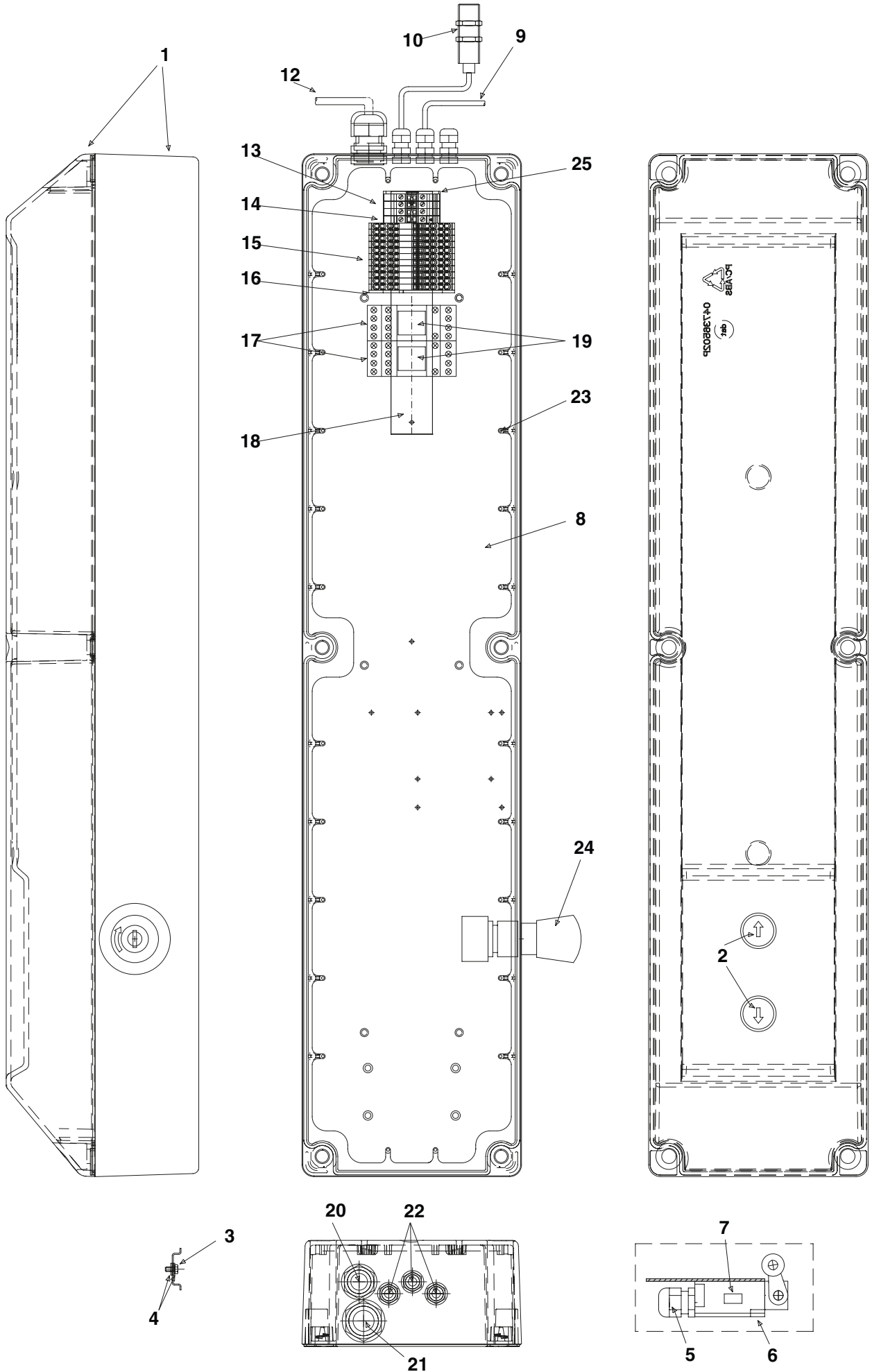

IMPIANTO ELETTRICO
ELECTRIC INSTALLATION

07E 0

RIF. REF	CODICE CODE	DESCRIZIONE	DESCRIPTION	APPLICAZIONE APPLICATION
1	047365390	CASSETTA ELETTRICA	EL.BOX RAV COVER	TUTTI I MODELLI ALL MODELS
2	517330	PULSANTE SINGOLO NERO CON FRECCIA BIANCA E ANELLO NERO E2	SINGLE BLACK BUTTON WITH WHITE ARROW AND BLACK RING E2	
2	517329	3 CONTATTI SUPPORTO IN PLASTICA E2	3 CONTACTS SUPPORT IN PLASTIC E2	
2	517352	BLOCCO CONTATTI, NO CON VITE E2	CONTACT BLOCK, NO WITH SCREW E2	
3	220005	VITE A TESTA CILINDRICA AUTOFIETTANTE	CYLINDRICAL HEAD SCREW SELF TAPPING	
4	239018	RONDELLA TAGLIATA DIAMETRO 4,3mm	NOTCHED WASHER DIAMETRO 4.3mm	
5	599252	PRESSACAVO PG11	CABLE GLAND PG11	
6	527083	MICROINTERRUTTORE FR552A	MICRO SWITCH FR552A	
7	999909190	ETICHETTA ADESIVA FC4 SECONDARIA COLL	ADHESIVE LABLE FC4 SLAVE COLLUMN	
8	047365050	PIASTRA ELETTRICA	ELECTRIC PLATE	
9	047365290	COLONNA SECONDARIA DISCESA MICRO SWTICH VERSIONE INTERFACCIA UTENTE FC4	SLAVE COLUMN LIFT DOWN MICRO SWTICH FC4 USER INTERFACE VERSION	
10	047365300	PROSSIMITÀ COLONNA SECONDARIA FCP2	SLAVE COLUMN PROXIMITY FCP2	
12	047365310	COLONNA SECONDARIA CAVO M2 VERSIONE INTERFACCIA UTENTE	SLAVE COLUMN M2 CABLE USER INTERFACE VERSION	
13	510244	MORSETTO A VITE DA 4MM	4MM SCREW CLAMP	
14	510251	MORSETTO A VITE IN PE 4MM	4MM PE SCREW CLAMP	
15	510263	MORSETTO 1.5mm 4 CONNESSIONI	CLAMP 1.5mm 4 CONNECTIONS	
16	510265	PIASTRA TERMINALE PER MORSETTO 1,5 mm 4 CONNESSIONI	END PLATE FOR CLAMP 1.5 mm 4 CONNECTIONS	
17	557028	RELÈ ZOCCOLO 4 CONTATTI	RELAY PLINTH 4 CONTACTS	
18	071665560	GUIDA DIN 7,5X15	DIN GUIDE 7.5X15	
19	557027	RELÈ A 4 CONTATTI	4 CONTACTS RELAY	
20	599429	PRESSACAVO M20X1.5	CABLE GLAND M20X1.5	
20	599432	ANELLO M20X1.5	RING M20X1.5	
21	599430	PRESSACAVO M25X1.5	CABLE GLAND M25X1.5	
21	599433	ANELLO M25X1.5	RING M25X1.5	
22	599611	PRESSACAVO M12X1.5	CABLE GLAND M12X1.5	
22	599431	ANELLO M12X1.5	RING M12X1.5	
23	220052	VITE A TESTA CILINDRICA AUTOFIETTANTE	CYLINDRICAL HEAD SCREW SELF TAPPING	
24	517351	PULSANTE DI EMERGENZA ROSSO CON SBLOCCO ROTANTE E2	EMERGENCY BUTTON RED WITH ROTATIVE RELEASE E2	
25	510249	PIASTRA FINALE 2,5mm-10mm	END PLATE 2.5mm-10mm	

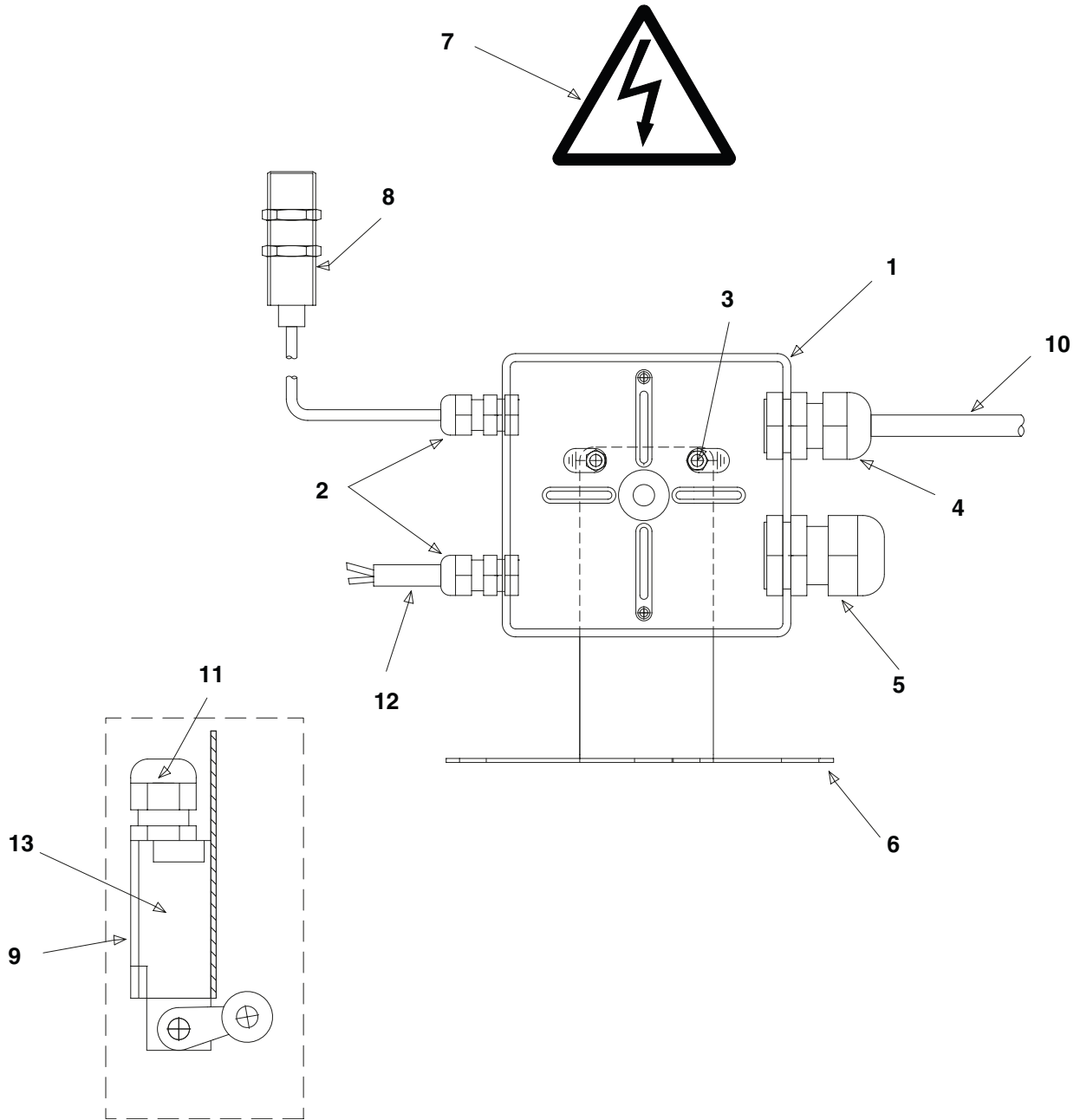

IMPIANTO ELETTRICO
ELECTRIC INSTALLATION

07F 0

RIF. REF	CODICE CODE	DESCRIZIONE	DESCRIPTION	APPLICAZIONE APPLICATION
1	047365240	SCATOLA DI DERIVAZIONE	ELECTRICAL JUNCTION BOX	TUTTI I MODELLI ALL MODELS
2	599428	PRESSACAVO M12X1.5	CABLE GLAND M12X1.5	
2	599431	ANELLO M12X1.5	RING M12X1.5	
3	99990491	ETICHETTA INDICATORE DI TERRA	GROUND INDICATOR LABLE	
3	224003	DADO ESAGONALE M4 Zn	HEXAGONAL NUT M4 Zn	
3	239018	DIAMETRO RONDELLA ESTERNA CON INTAGLIO 4,3mm	EXTERNAL NOTCHED WASHER DIAMETER 4.3mm	
3	206226	VITE TCEI M4x20 Zn	SCREW TCEI M4x20 Zn	
4	599429	PRESSACAVO M20X1.5	CABLE GLAND M20X1.5	
4	599432	ANELLO M20X1.5	RING M20X1.5	
5	599430	PRESSACAVO M25X1.5	CABLE GLAND M25X1.5	
5	599433	ANELLO M25X1.5	RING M25X1.5	
6	047318750	PIASTRA DI SUPPORTO PER SCATOLA DI GIUNZIONE	SUPPORT PLATE FOR JUNCTION BOX	
7	99990758	ETICHETTA DI PERICOLO TENSIONE	VOLTAGE DANGER LABLE	
8	047365161	PROXIMITY COLONNA SECONDARIA FCP2 CON CAVO	SAVE COLLUM PROXIMITY FCP2 WITH CABLE	
9	527083	MICROINTERRUTTORE FR552A	MICRO SWITCH FR552A	
10	047365121	CAVO COLONNA SECONDARIA M2	SLAVE COLLUM M2 CABLE	
11	599252	PRESSACAVO PG11	CABLE GLAND PG11	
12	047365171	CAVO MICRO INTERRUTTORE COLONNA SECONDARIA DISCESA FC4 2X1	SLAVE COLLUM LIFT DOWN MICRO SWITCH CABLE FC4 2X1	
13	999909190	ETICHETTA ADESIVA FC4 SLAVE COLL	ADHESIVE LABLE FC4 SLAVE COLLUMN	

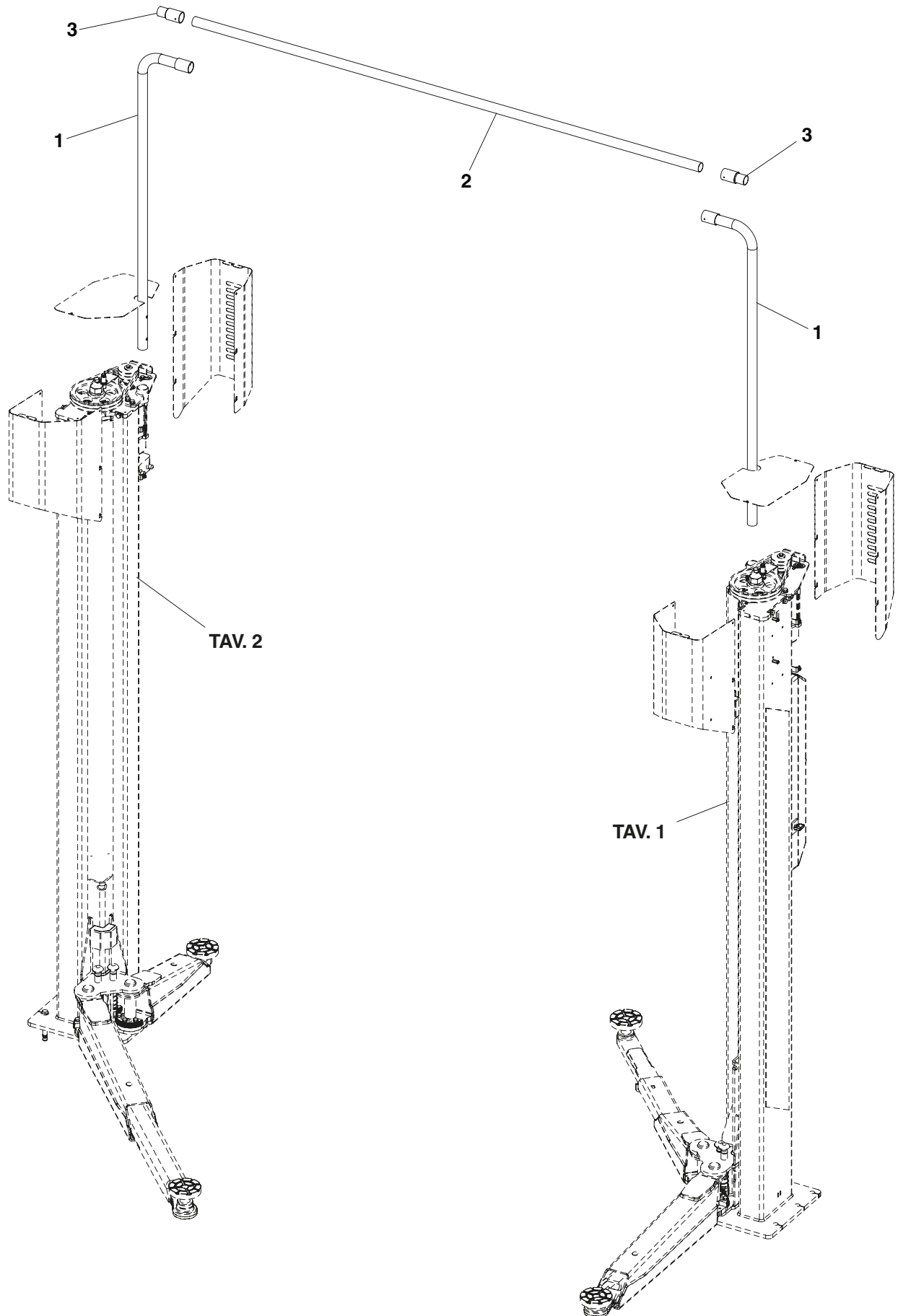



Denominazione tavola – Table definition

N°
tavolaTable
NoIndice di
modificaChange
indexIMPIANTO ELETTRICO
ELECTRIC INSTALLATION**08** **0**

RIF. REF	CODICE CODE	DESCRIZIONE	DESCRIPTION	APPLICAZIONE APPLICATION
1	047318210	TUBO VERTICALE	VERTICAL TUBE	TUTTI I MODELLI ALL MODELS
2	047318180	TUBO SUPERIORE	UPPER TUBE	
3	047318970	PROLUNGA 100mm	EXTENSION 100mm	

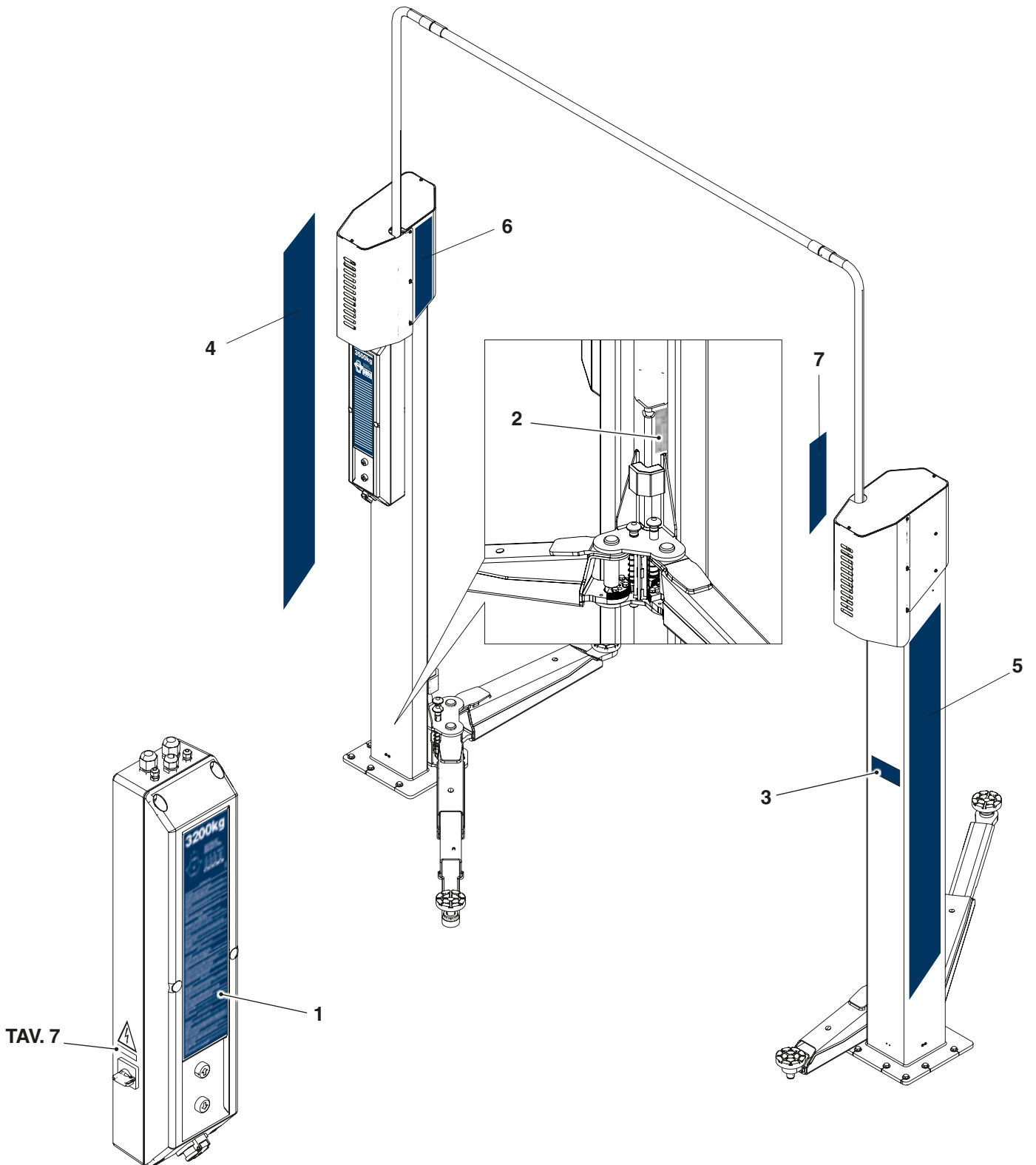

ADESIVI E TARGHETTE
STICKERS AND PLATES

09 0

RIF. REF	CODICE CODE	DESCRIZIONE	DESCRIPTION	APPLICAZIONE APPLICATION
1	999925250	ADESIVO UNICO PER 3200 Kg	SINGLE ADHESIVE FOR 3200 Kg	KPX32
1	999925230	ADESIVO UNICO PER 3500 Kg	SINGLE ADHESIVE FOR 3500 Kg	KPX35
2	999912810	TARGA MATRICOLA	SERIAL NUMBER PLATE	TUTTI I MODELLI ALL MODELS
3	999925100	TARGHETTA PORTATA 3200 Kg	PLATE CAPACITY 3200 Kg	KPX32
3	999925050	TARGHETTA PORTATA 3500 Kg	PLATE CAPACITY 3500 Kg	KPX35
4	999925350	ADESIVO RAV COLONNA COMANDO	STICKER RAV CONTROL COLUMN	TUTTI I MODELLI ALL MODELS
5	999925360	ADESIVO RAV COLONNA OPPOSTA	STICKER RAV OPPOSITE COLUMN	
6	999924920	ADESIVO RAV CARTER DX	RH STICKER RAV CARTER	
7	999924930	ADESIVO RAV CARTER SX	LH STICKER RAV CARTER	



Ravaglioli

- Per eventuali chiarimenti interpellare il più vicino rivenditore oppure rivolgersi direttamente a
Servizio assistenza tecnica: **RAVAGLIOLI S.p.A.** - Via 1° Maggio, 3 - 40037 Pontecchio Marconi - Bologna Italia
Tel. (+39) 051 6781511 - Telex 510697 RAV I - Fax (+39) 051 846349 - e-mail: aftersales@ravaglioli.com

- For any further information please contact your nearest dealer or speak directly to
Technical services: **RAVAGLIOLI S.p.A.** - Via 1° Maggio, 3 - 40037 Pontecchio Marconi - Bologna Italy
Phone (+39) 051 6781511 - Telex 510697 RAV I - Fax (+39) 051 846349 - e-mail: aftersales@ravaglioli.com

- Im Zweifelsfall oder bei Rückfragen wenden Sie sich bitte an den nächsten Händler oder direkt an:
Kundendienst: **RAVAGLIOLI S.p.A.** - Via 1° Maggio 3, 40037 Pontecchio Marconi - Bologna - Italien
Telefon (+39) 051 6781511 - Telex 510697 RAV I - Fax (+39) 051 846349 - e-mail: aftersales@ravaglioli.com

- Pour tout renseignement complémentaire, s'adresser au distributeur le plus proche ou directement à:
Service Après-Vente: **RAVAGLIOLI S.p.A.** - via 1° Maggio 3 - 40037 - Pontecchio Marconi - Bologne - Italie
Tél. (+39) 051 6781511 - Téléx 510697 RAV I - Fax (+39) 051 846349 - e-mail: aftersales@ravaglioli.com

- En caso de dudas, para eventuales aclaraciones, póngase en contacto con el distribuidor más próximo o diríjase directamente a:
Servicio Post-Venta: **RAVAGLIOLI S.p.A.** - Via 1° Maggio, 3 - 40037 Pontecchio Marconi - Bologna - Italia
Tel. (+39) 051 6781511 - Telex 510697 RAV I - Fax (+39) 051 846349 - e-mail: aftersales@ravaglioli.com
