







Ravaglioli

KPS
306H
244H

COMPANY WITH
QUALITY SYSTEM
CERTIFIED BY DNV GL
= ISO 9001 =

- SOLLEVATORI A DUE COLONNE CON TRASMISSIONE A CARDANO 
- TWO POSTS LIFTS WITH SHAFT TRANSMISSION 
- 2-SÄULEN-HEBEBÜHNEN MIT WELLENÜBERTRAGUNG 
- ELEVATEURS DEUX COLONNES AVEC TRANSMISSION PAR CARDAN 
- ELEVADORES DE DOS COLUMNAS CON TRANSMISIÓN POR CARDAN 



INCLUDES NEW MODEL
KPS 244HELIKA 

SHAFT DRIVE
From 3200 to 4000 kg

Self Supporting Base

SYNCHRONIZATION BY SHAFT

Trasmissione fra le colonne tramite barra rotante e scatole angolari con ingranaggi conici a bagno d'olio che non richiedono alcuna manutenzione.

Shaft transmission between posts through oil-filled conic gear boxes requiring no maintenance.

Die Übertragung zwischen den Säulen erfolgt mittels einer Welle und Winkelgetrieben mit Kegelräderpaar in Ölbad, die keiner Wartung bedürfen.

Transmission entre colonnes par cardan et boîtiers à couples d'engrenages coniques à bain d'huile qui ne nécessitent pas d'entretien.

Transmisión entre las columnas por cardan y cajas de engranajes selladas en baño de aceite que no requieren mantenimiento alguno.

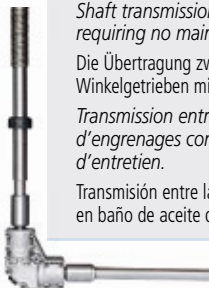

Space Saving Base





K

KPS 306LHEK / 3200 kg large

Bracci predisposti per l'alloggiamento rapido di prolunghhe.

Arms suitable for quick drop-in extensions.

Aufnahmen mit Schnellstecksystem erleichtern den Einsatz von Verlängerungen.

Bras prévus pour le montage rapide de rallonges.

Brazos predispuestos para el alojamiento rápido de suplementos.

R RACING

KPS 306LHER / 3200 kg

Bracci super-ribassati, con profilo parallelo al pavimento per tutta la lunghezza del braccio: tamponi a doppio filo con altezza minima di soli 80 mm.

Very low profile arms, parallel to the floor: double thread pads with a min. height of 80mm only.

Sehr niedrige Arme, und zwar die ganze Länge entlang paralleles Profil zum Boden. Aufnahmen mit Stecksystem und 80mm Unterschenkhöhe

Bras extra plats, avec profil parallèle au sol sur toute la longueur: tampons à double rallonge avec hauteur mini. de seulement 80 mm.

Brazos extra bajos, con perfil paralelo al suelo a lo largo del brazo entero: tacos de doble extensión con altura mínima del suelo de sólo 80 mm.

KPS 306LHEK, LHER

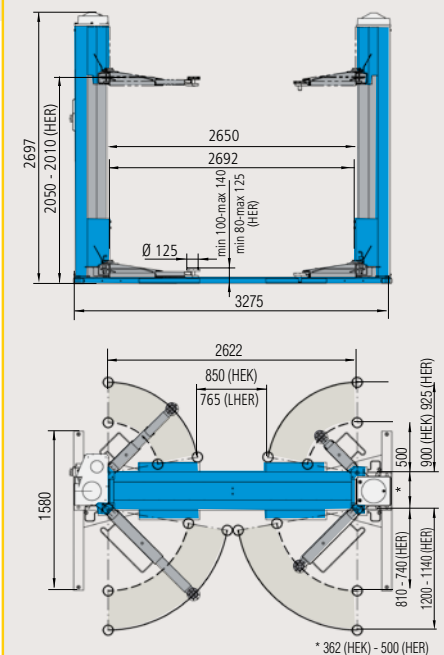

Shaft Drive + Self Supporting Base

L'esclusivo ponte RAV con pedana portante e trasmissione a cardano. Installazione possibile anche su pavimenti che non garantiscono un ancoraggio al suolo sicuro.

The exclusive RAV lift with self supporting base and shaft transmission. Installation is possible on floor with poor surface anchorage.

Die exclusive RAV Hebebühne mit tragendem Grundrahmen und Welleübertragung. Montage auch auf Böden, die keine gute Fixierung ermöglichen.

Le pont exclusif RAVA à base porteuse et transmission par cardan. L'installation est possible même sur un sol qui ne garantit pas un bon ancrage.

El exclusivo elevador RAV con base portante y transmisión por cardan. Instalación posible sobre suelos que no garantizan un anclaje seguro.

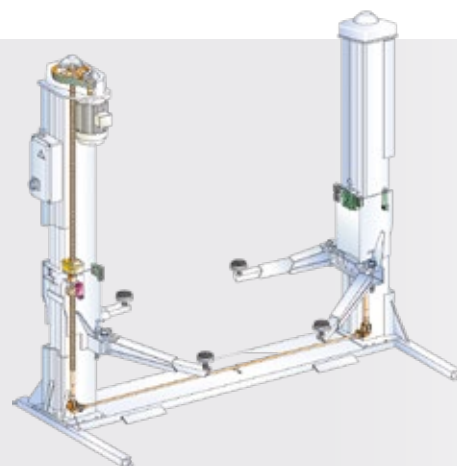

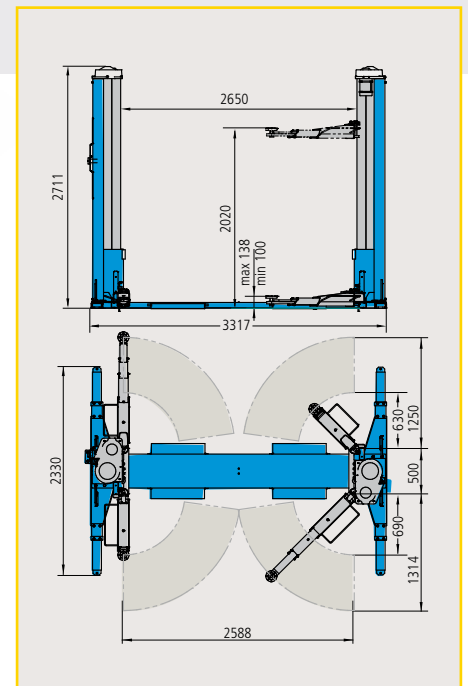

KPS 244HELIKA / 4000 kg - 2 motors

Modello equipaggiato con **due bracci lunghi a 3 stadi e due a 4 stadi**: ideali per il sollevamento di furgoni e **furgonati a passo lungo**, consentono allo stesso tempo caricabilità ottimale anche per le autovetture.

*Model equipped with **two long 3-stage arms and two long 4-stage arms**: ideal to lift **long wheel base vans** and easy lifting of cars.*

Modell mit **zwei zweifach und zwei dreifach ausziehbaren langer Armen**: ideal zum Heben von **Lieferwagen auch mit langem Radstand** und garantiert auch eine optimale Aufnahme von PKW.

*Élévateur équipé de **deux bras longs à 3 étages et deux à 4 étages**: idéal pour le levage de **furgons à châssis long**, il garantit aussi le levage optimal des voitures.*

Modelo equipado con **dos brazos largos de 3 extensiones y dos de 4 extensiones**: ideal sea para el levantamiento de **furgonetas normales y de chasis largo** sea de turismo.

QUICK FIT SYSTEM

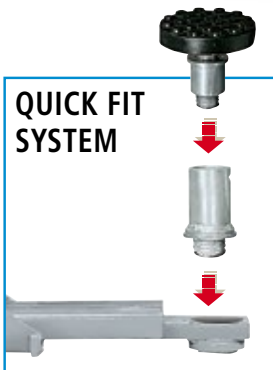

SYNCHRONIZATION BY SHAFT

Trasmissione fra le colonne tramite barra rotante e scatole angolari con ingranaggi conici a bagno d'olio che non richiedono alcuna manutenzione.

Shaft transmission between posts through oil-filled conic gear boxes requiring no maintenance.

Die Übertragung zwischen den Säulen erfolgt mittels einer Welle und Winkelgetrieben mit Kegelhäderpaar in Ölbad, die keiner Wartung bedürfen.

Transmission entre colonnes par cardan et boîtiers à couples d'engrenages coniques à bain d'huile qui ne nécessitent pas d'entretien.

Transmisión entre las columnas por cardan y cajas de engranajes selladas en baño de aceite que no requieren mantenimiento alguno.

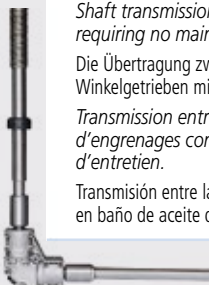

Space Saving Base

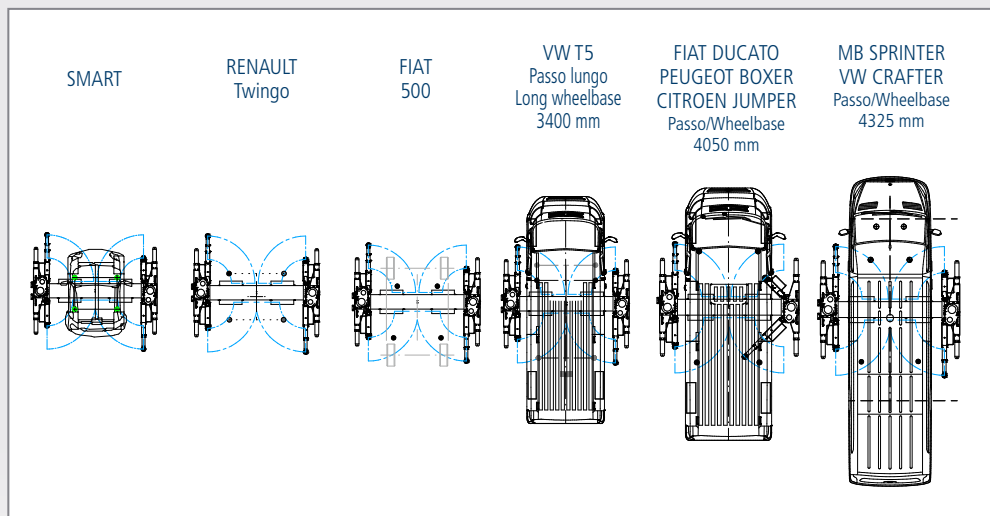

OPTIONS → K, LIK, LIKA

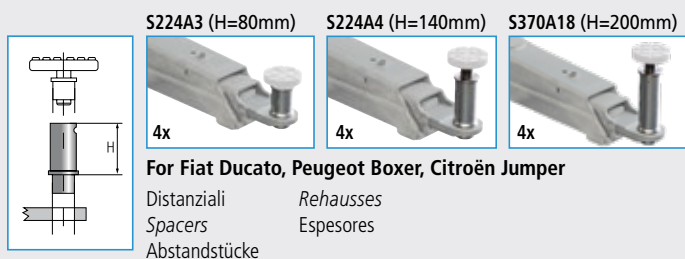

For Fiat Ducato, Peugeot Boxer, Citroën Jumper

Distanziali
Spacers
Abstandstücke

Rehausses
Espesores

OPTIONS → S224A3, S224A4, S370A18

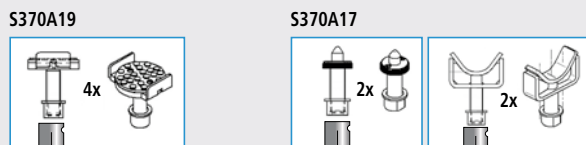

S370A19

Supporti presa telaio
Frame adapters
Halterungen für Chassisaufnahme
Supports prise sur chassis
Espesores de agarre sobre chasis

S370A17

For Mercedes Sprinter, VW LT+Crafter

Supporti
Adapters
Halterungen

Supports
Adaptadores
de agarre



Ravaglioli S.p.A.

via 1° maggio 3
Fraz. Pontecchio M.
40037 Sasso Marconi BO - Italia
Phone +39.051.6781511
Fax. +39.051.846349
E-mail: rav@ravaglioli.com

RAV France

4, Rue Longue Raie
ZAC de la Tremblaie
91220 Le Plessis Pâté
Phone 01.60.86.88.16
Fax. 01.60.86.82.04
E-mail: rav@ravfrance.fr

Ravaglioli in Germany

Vehicle Service Group
Hüfanger Straße 55
78199 Bräunlingen - Germany
Phone +49.771.9233.0
Fax. +49.771.9233.99
E-mail: rav@ravaglioli.com

Ravaglioli in UK

Vehicle Service Group UK Ltd
3 Fourth Avenue, Bluebridge Industrial Estate
Halstead, Essex, CO9 2SY, UK
Phone +44.1787.477711
Fax. +44.1787.477720
E-mail: rav@ravaglioli.com

DRD04U (9)

Le caratteristiche tecniche e gli allestimenti presentati in questo prospetto possono subire variazioni. Le immagini riprodotte non sono vincolanti.
Technical data and composition presented in this catalogue may vary. Pictures reproduced are only indicative.
Die techn. Daten und die Ausrüstungen, die in diesem Prospekt enthalten sind, können Änderungen erfahren. Deshalb sind die Abbildungen unverbindlich.
Les caractéristiques techniques et les compositions présentées dans ce prospect peuvent subir des variations. Les images reproduites n'ont qu'une valeur indicative.
Las características técnicas y las composiciones ilustradas en este folleto pueden sufrir variaciones. Las imágenes propuestas son solamente indicativas.

Member of VSG - Vehicle Service Group
a **DOVER** company

